



USERS MANUAL / GEBRUIKERSHANDLEIDING / BETRIEBSANLEITUNG  
MANUEL UTILISATEUR / MANUAL DE UTILIZACION / INSTRUZIONI PER L'USO

# CHARGEMASTER 1

12/35-3, 12/50-3, 24/20-3, 24/30-3

FULL AUTOMATIC BATTERY CHARGER



MASTERVOLT  
Snijdersbergweg 93,  
1105 AN Amsterdam  
The Netherlands  
Tel.: +31-20-3422100  
Fax.: +31-20-6971006  
www.mastervolt.com



ENGLISH:	PAGE 1
NEDERLANDS:	PAGINA 29
DEUTSCH:	SEITE 57
FRANÇAIS:	PAGINA 85
CASTELLANO:	PÁGINA 113
ITALIANO:	PÁGINA 141

## CONTENTS:

v 1.3 August 2009

<b>1</b>	<b>GENERAL INFORMATION.....</b>	<b>4</b>
1.1	Use of this manual.....	4
1.2	Validity of this manual .....	4
1.3	Use of pictograms .....	4
1.4	Identification label.....	4
1.5	Liability .....	4
<b>2</b>	<b>IMPORTANT SAFETY INSTRUCTIONS .....</b>	<b>5</b>
2.1	General .....	5
2.2	Explosive gases .....	5
2.3	Warnings regarding the use of batteries.....	6
2.4	Warning regarding life support applications.....	6
2.5	Guarantee specifications.....	6
<b>3</b>	<b>OPERATION .....</b>	<b>7</b>
3.1	Features .....	7
3.2	Switching on / stand-by .....	7
3.3	Display .....	8
3.4	Three Step charge algorithm.....	8
3.4.1	Temperature compensated charging.....	9
3.4.2	Connection of a second and third battery.....	9
3.5	Masterbus (optional).....	9
3.6	Maintenance.....	9
3.7	Failures.....	9
<b>4</b>	<b>INSTALLATION .....</b>	<b>10</b>
4.1	Unpacking .....	10
4.2	Environment.....	10
4.3	Wiring .....	10
4.3.1	AC wiring.....	10
4.3.2	DC wiring.....	10
4.3.3	Battery capacity.....	11
4.3.4	AC safety grounding.....	11
4.4	Overview connection compartment.....	11
4.5	Things you need.....	12
4.6	Connection .....	12
4.6.1	Connection example.....	13
4.7	Installation step by step.....	14
4.8	Commissioning after installation.....	14
4.8.1	General.....	14
4.8.2	MasterBus .....	14
4.9	Decommissioning .....	14
4.10	Storage and transportation.....	14
4.11	Re-installation.....	14
<b>5</b>	<b>SETTINGS .....</b>	<b>15</b>
5.1	DIP Switch settings .....	15
5.1.1	DIP switch 1: Battery type .....	15
5.1.2	DIP switch 2: Charge algorithm .....	15
5.1.3	DIP-switch 3: Stand-by mode for display.....	15
5.1.4	DIP switch 4: Equalize mode.....	15

<b>6</b>	<b>MASTERBUS.....</b>	<b>16</b>
6.1	What is MasterBus? .....	16
6.2	How to set up a MasterBus network .....	17
6.3	MasterBus: Monitoring and Programming of the ChargeMaster.....	18
6.3.1	Monitoring.....	18
6.3.2	Alarms .....	18
6.3.3	History .....	18
6.3.4	Configuration .....	19
6.3.5	ChargeMaster 1 event source list (ChargeMaster as event source).....	20
6.3.6	ChargeMaster event target list (ChargeMaster as event target).....	20
<b>7</b>	<b>TROUBLE SHOOTING .....</b>	<b>21</b>
7.1	Fault finding table .....	21
<b>8</b>	<b>TECHNICAL DATA.....</b>	<b>22</b>
8.1	Specifications 12V models .....	22
8.2	Specifications 24V models .....	23
8.3	Dimensions.....	24
8.4	Characteristics.....	25
<b>9</b>	<b>ORDERING INFORMATION.....</b>	<b>27</b>
9.1	MasterBus installation components.....	27
9.2	Miscellaneous.....	27
<b>10</b>	<b>EC DECLARATION OF CONFORMITY .....</b>	<b>28</b>

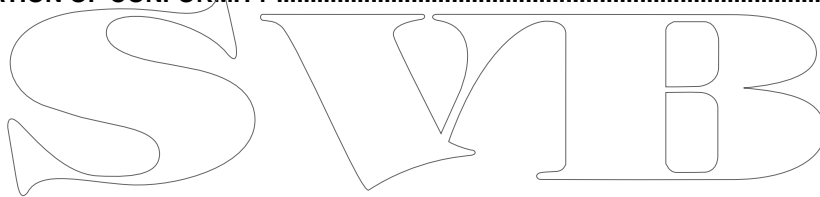
The logo consists of the letters 'S', 'V', and 'B' in a large, stylized, outlined font. The 'S' is on the left, 'V' is in the middle, and 'B' is on the right. The letters are interconnected and have a decorative, slightly irregular shape.

# 1 GENERAL INFORMATION

## 1.1 USE OF THIS MANUAL

This manual contains important safety and operating instructions for the safe and effective operation, maintenance and possible correction of minor malfunctions of the Chargemaster1.

It is therefore obligatory that every person who works on or with the Chargemaster must be completely familiar with the contents of this manual, and that he/she carefully follows the instructions and important safety instructions contained herein. The English version has 28 pages. Copyright © 2009 Mastervolt. All rights reserved. Reproduction, transfer, distribution or storage of part or all of the contents in this document in any form without the prior written permission of Mastervolt is prohibited.

## 1.2 VALIDITY OF THIS MANUAL

All of the specifications, provisions and instructions contained in this manual apply solely to standard versions of the Chargemaster delivered by Mastervolt.

This manual is valid for the following models:

Part number	Model
44010350	ChargeMaster 12/35-3
44010500	ChargeMaster 12/50-3
44020200	ChargeMaster 24/20-3
44020300	ChargeMaster 24/30-3

These models are mentioned as "Chargemaster" further in this manual. For other models see the other manuals available on our website: [www.mastervolt.com](http://www.mastervolt.com)

## 1.3 USE OF PICTOGRAMS

Safety instructions and warnings are marked in this manual by the following pictograms:



### WARNING

A WARNING refers to possible injury to the user or significant material damage to the charger if the user does not (carefully) follow the procedures.



### CAUTION!

Special data, restrictions and rules with regard to preventing damage.



A procedure, circumstance, etc which deserves extra attention.

## 1.4 IDENTIFICATION LABEL

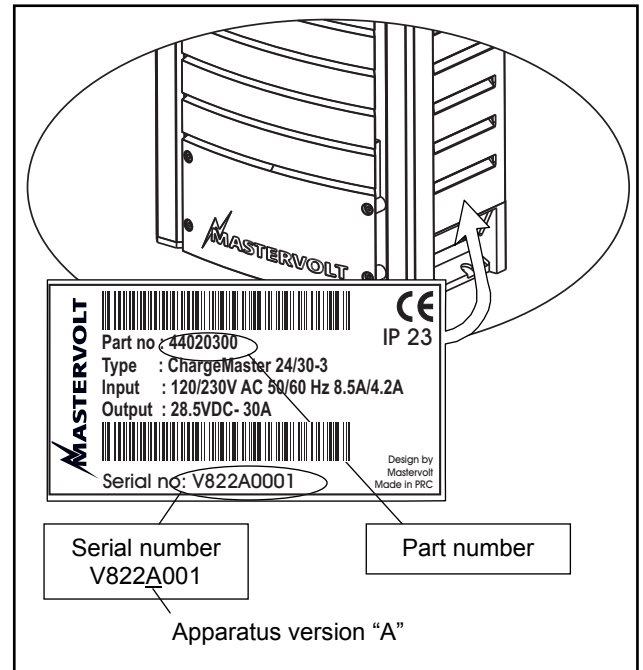

Figure 1: Identification label

The identification label is located at the right-hand side of the Chargemaster. (see figure 1) Important technical information required for service, maintenance & secondary delivery of parts can be derived from the identification label.



### CAUTION!

Never remove the identification label.

## 1.5 LIABILITY

Mastervolt can accept no liability for:

- consequential damage due to use of the Chargemaster;
- possible errors in the manuals and the results thereof.

## 2 IMPORTANT SAFETY INSTRUCTIONS

### READ AND SAVE THESE INSTRUCTIONS



**WARNING**

This chapter describes important safety and operating instructions for use of a Chargemaster in residential, recreational vehicle (RV) and marine applications.

**2.1 GENERAL**

- 1 Before using the Chargemaster, read all instructions and cautionary markings on the Chargemaster, the batteries, and all appropriate sections of the manual.
- 2 To reduce the risk of electric shock – Do not expose Chargemaster to rain, snow, spray, moisture, excessive pollution and condensing circumstances. To reduce risk of fire hazard, do not cover or obstruct the ventilation openings. Do not install the Chargemaster in a non-ventilated room, overheating may result.
- 3 Use of an attachment or spare part not recommended or sold by Mastervolt may result in a risk of fire, electric shock, or injury to persons.
- 4 The Chargemaster is designed to be permanently connected to an AC and DC electrical system. Installation of, and work on the Chargemaster, may be carried out only by a qualified, authorised and trained technician or electrician, consistent with the locally applicable standards and regulations.
- 5 Make sure that all wiring is properly installed and in good electrical condition; and that wire size is large enough for AC ampere rating of the Chargemaster. Check the wiring on a regular base, at least once a year. Do not use the Chargemaster when the wiring is undersized or damaged.
- 6 Do not operate Chargemaster if it has received a sharp blow, been dropped, or otherwise damaged in any way; take it to a qualified serviceman.
- 7 Except for the connection compartment, see chapter 4, the Chargemaster may not be opened or disassembled. There are no serviceable parts inside the cabinet. Take it to a qualified, authorized and trained serviceman when service or repair is required. Incorrect reassembly may result in a risk of electric shock or fire. Only qualified, electrician installers are authorized to open the connection compartment.
- 8 To reduce risk of electric shock, disconnect the Chargemaster from both AC and DC electrical system

before attempting any maintenance or cleaning. Turning off controls will not reduce this risk.

- 9 The Chargemaster must be provided with an equipment-grounding conductor to the AC-input ground terminal. Grounding and all other wiring must comply with local codes and ordinances.
- 10 Short circuiting or reversing polarity will lead to serious damage to batteries, Chargemaster, wiring as well as accessories. Fuses can not prevent damage caused by reversed polarity and the warranty will be void.
- 11 In case of fire, you must use the fire extinguisher which is appropriate for electrical equipment.
- 12 If applied in a marine application in the United States, external connections to the Chargemaster shall comply with the United States Coast Guard Electrical Regulations (33CFR183, Sub part I).

**2.2 EXPLOSIVE GASES**

- 1 **WARNING – RISK OF EXPLOSIVE GASES. WORKING IN VICINITY OF A LEAD-ACID BATTERY IS DANGEROUS. BATTERIES GENERATE EXPLOSIVE GASES DURING NORMAL BATTERY OPERATION. FOR THIS REASON, IT IS OF UTMOST IMPORTANCE THAT EACH TIME BEFORE USING THE CHARGEMASTER, YOU READ THIS MANUAL AND FOLLOW THE INSTRUCTIONS EXACTLY.**
- 2 To reduce risk of battery explosion, follow these instructions and those published by battery manufacturer and manufacturer of any equipment you intend to use in vicinity of the battery. Review cautionary marking on these products.
- 3 **DANGER:** To reduce the risk of explosion – Never use the Chargemaster in situations where there is danger of gas or dust explosion or area in which ignition-protected equipment is required.

## 2.3 WARNINGS REGARDING THE USE OF BATTERIES

- 1 Someone should be within range of your voice or close enough to come to your aid when you work near a lead-acid battery.
- 2 Have plenty of fresh water and soap nearby in case battery acid contacts skin, clothing, or eyes.
- 3 Wear complete eye protection and clothing protection. Avoid touching eyes while working near battery.
- 4 If battery acid contacts skin or clothing, wash immediately with soap and water. If acid enters eye, immediately flood eye with running cold water for at least 10 minutes and get medical attention immediately.
- 5 NEVER smoke or allow a spark or flame in vicinity of battery or engine.
- 6 Do not short circuit batteries, as this may result in explosion and fire hazard! Be extra cautious to reduce risk of dropping a metal tool onto battery. It might spark or short-circuit battery or other electrical part that may cause explosion.
- 7 Remove personal metal items such as rings, bracelets, necklaces, and watches when working with a lead-acid battery. A lead-acid battery can produce a short-circuit current high enough to weld a ring or the like to metal, causing a severe burn.
- 8 Only use Chargemaster for charging a LEAD-ACID batteries and the supply of users attached to these batteries, in permanent systems. Do not use Chargemaster for charging dry-cell batteries that are commonly used with home appliances. These batteries may burst and cause injury to persons and damage to property.
- 9 NEVER charge a frozen battery.
- 10 Excessive battery discharge and/or high charging voltages can cause serious damage to batteries. Do not exceed the recommended limits of discharge level of your batteries.
- 11 If it is necessary to remove a battery, always remove grounded terminal from battery first. Make sure all accessories are off, so as not to cause an arc.

- 12 Be sure that the area around battery is well ventilated while battery is being charged. Refer to the recommendations of the battery manufacturer.
- 13 Batteries are heavy! It may become a projectile if it is involved in an accident! Ensure adequate and secure mounting and always use suitable handling equipment for transportation.

## 2.4 WARNING REGARDING LIFE SUPPORT APPLICATIONS

The Chargemaster is not sold for applications in any medical equipment intended for use as a component of any life support system unless a specific written agreement pertaining to such intended use is executed between the manufacturer and Mastervolt. Such agreement will require the equipment manufacturer either to contract additional reliability testing of the Chargemaster and/or to commit to undertake such testing as a part of the manufacturing process. In addition the manufacturer must agree to indemnify and not hold Mastervolt responsible for any claims arising from the use of the Chargemaster in the life support equipment.

## 2.5 GUARANTEE SPECIFICATIONS

Mastervolt guarantees that this unit has been built according to the legally applicable standards and specifications. Should work take place, which is not in accordance with the guidelines, instructions and specifications contained in this users manual, then damage may occur and/or the unit may not fulfil its specifications. All of these matters may mean that the guarantee becomes invalid.

The guarantee is limited to the costs of repair and/or replacement of the product. Costs for installation labor or shipping of the defective parts are not covered by this guarantee.

### 3 OPERATION

#### 3.1 FEATURES

The Mastervolt Chargemaster is a fully automatic battery charger. This means that under normal circumstances it may stay switched on with the AC power and batteries connected. The Chargemaster is suitable for charging of lead-acid batteries which may include maintenance-free, low maintenance, AGM/spiral, gel or deep-cycle batteries. It has an auto-ranging input facility which makes it feasible to operate on almost any AC power source in the world. It operates smoothly on both 230V as well as on 120V without any compromises for the output current. The three-step Plus charging method guarantees that the batteries are always charged to 100%.

With an external AC source connected, the Chargemaster charger also serves the function of an AC to DC converter to supply DC loads which are connected to the batteries.

#### 3.2 SWITCHING ON / STAND-BY

The Chargemaster is activated by holding the POWER switch pressed for approx. 3 seconds. The POWER switch will illuminate green. The state of charge (which is stored in the memory of the Chargemaster) will be displayed. If necessary and if AC power is available, the Chargemaster will start to charge the batteries.



Once switched on, the ChargeMaster automatically resumes operation after it was disconnected from an AC-source temporarily.

By pressing the POWER button again for approx. 3 seconds, the Chargemaster will switch back to stand-by: the Chargemaster stops and the POWER switch illuminates red.



#### **WARNING**

Switching the Chargemaster to “stand-by” does not cut off the connection to the batteries or the AC-source. This means that voltages are still available inside the apparatus.

If the Chargemaster was switched to stand-by or AC power became unavailable, the POWER switch starts to blink red. After approximately 2 minutes the blinking will stop and the display will switch off, thus preventing battery load by the indication light.

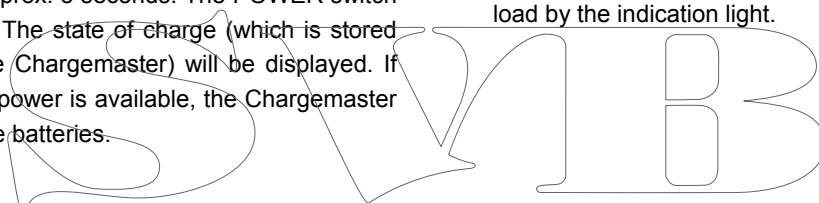

**3.3 DISPLAY**

The Chargemaster is equipped with a multicolour LED display. Different LED colours and combinations have different meanings. Combination of the current display (A)

with the load bar shows the percentage of maximum current, of the three Battery banks together. Combination of (V) with the load bar shows the actual charging voltage.

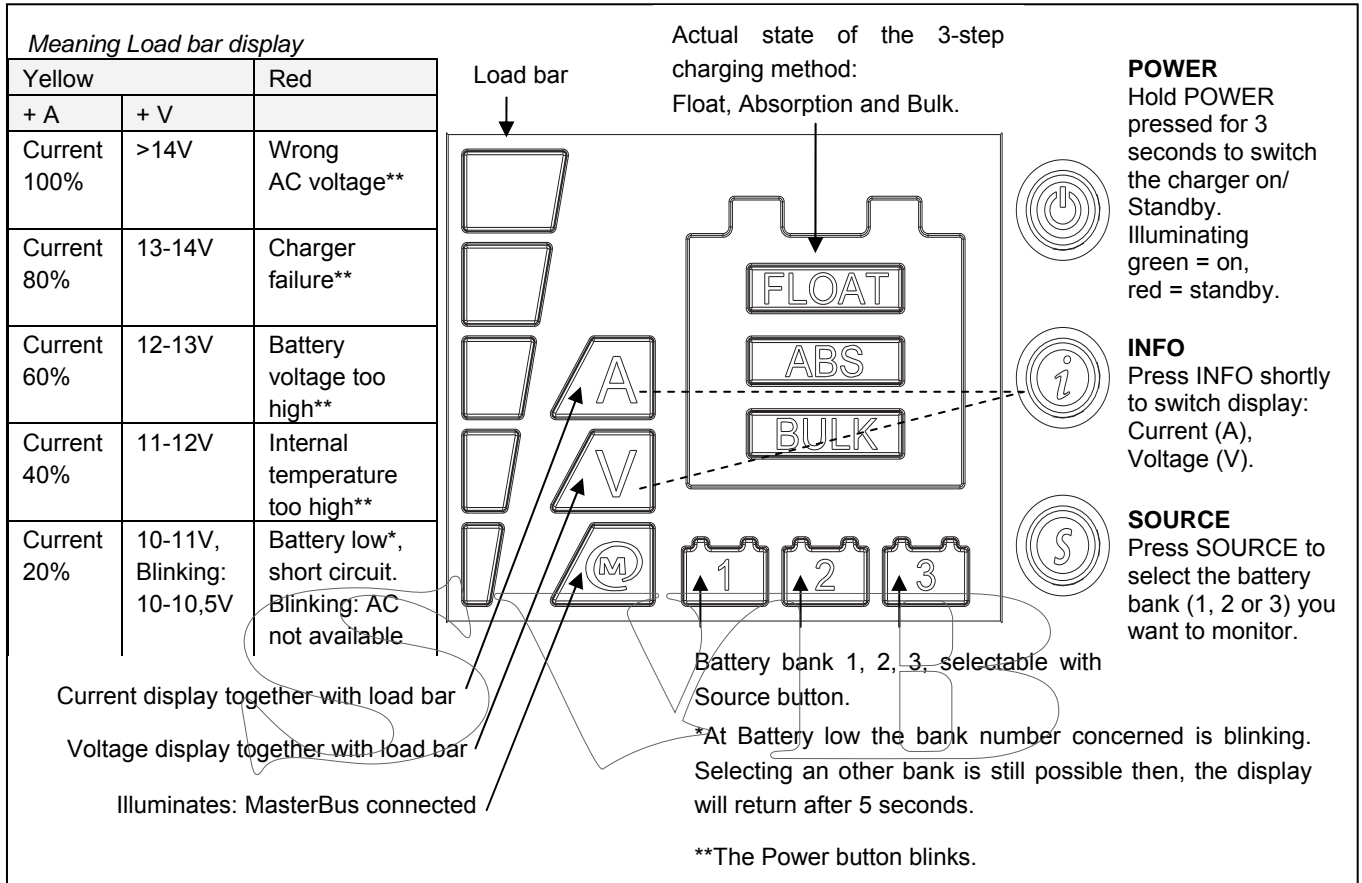

Figure 2: Display operation of the Chargemaster

**3.4 THREE STEP CHARGE ALGORITHM**

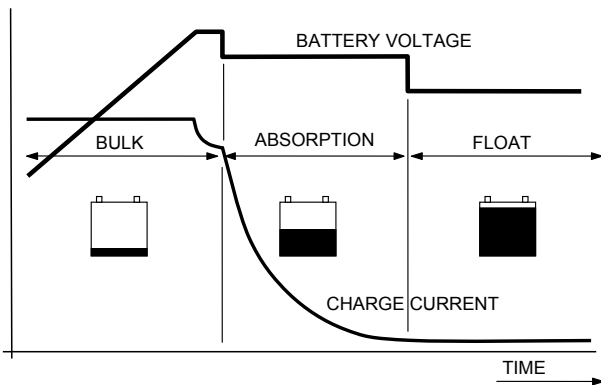

Figure 3: Three step Plus charge system

The first step of the three step Plus charge system is the BULK phase, in which the output current of the charger is 100%, and the greater part of the capacity of the battery is rapidly charged. The current charges the batteries and gradually the voltage rises to the absorption voltage of 14.4V (12V models) or 28.8V (24V models) at 25°C / 77°F. The duration of this phase depends on the ratio of battery to charger capacity, and also on the degree to which the batteries were discharged to begin with.

See figure 3. Battery charging is accomplished in three automatic stages: BULK, ABSORPTION and FLOAT.



The bulk phase is followed by the ABSORPTION phase. Absorption charging starts when the voltage on the batteries has reached 14.4V (12V models) / 28.8V (24V models) at 25°C / 77°F, and ends when the battery is completely full. Battery voltage remains constant at 14.25V (12V models) / 28.5V (24V models) at 25°C / 77°F throughout this stage, and the charge current depends on the degree to which the battery was initially discharged, the battery type, the ambient temperature, and so on. With a wet cell battery this stage lasts some four hours, with gel and AGM around three. Once the battery is 100% full, the Chargemaster automatically switches over to the float phase.

During the FLOAT phase the Chargemaster switches to 13.25V (12V models) or 26.5V (24V models) at 25°C / 77°F and stabilises this voltage to maintain the batteries in an optimum condition. Connected DC-loads are powered directly by the charger. If the load is higher than charger capacity, the required additional power comes from the battery, which will be progressively discharged until the charger automatically switches back to the bulk phase. Once consumption decreases, the charger goes back to normal operation of the three-step charge system.

As the Chargemaster is equipped with a three-step Plus charge system, the batteries can also remain connected to the Chargemaster in winter. One hour every 12 days the charger automatically switches to absorption to keep the battery running properly and prolong its life span. The three-step Plus charge system is also safe for all the connected equipment.



See also section 8.4 for detailed characteristics of the three step Plus charge system.

### 3.4.1 Temperature compensated charging

By installing the battery temperature sensor the charge voltages are automatically adapted for deviating temperatures.

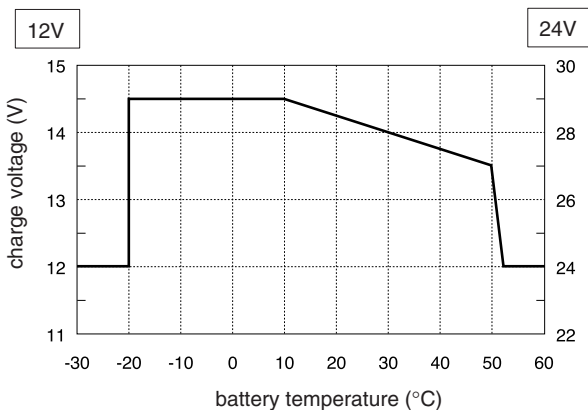

Figure 4: Temperature compensated charging

See figure 4. When the battery temperature is low, the charge voltage increases. On the other hand, when the battery temperature is high, the charge voltage is decreased. Over charge and gassing are prevented this way. This will extend the life of your batteries.

### 3.4.2 Connection of a second and third battery

The Chargemaster is equipped with three equal outputs. The total output current is divided over these three outputs. See section 4.6 for connection.

### 3.5 MASTERBUS (OPTIONAL)

The Chargemaster is compatible with the MasterBus network: a fully decentralized data network for communication between the different Mastervolt system devices such as the inverter, battery charger, generator, batteries and many more. See chapter 6 for details.

### 3.6 MAINTENANCE

No specific maintenance to the Chargemaster is required. Examine your electrical installation on a regular base, at least once a year. Defects such as loose connections, burnt wiring etc. must be corrected immediately.

If necessary, use a soft clean cloth to clean cabinet of the Chargemaster. Never use any liquids, acids and/or scourers.

### 3.7 FAILURES

The Chargemaster is protected against overload, short circuit, over heating and under and over voltage. If a fault condition occurs, a load bar segment on the display illuminates red. The LED position indicates the failure cause. See section 3.3 and 7.1 for explanation.



#### CAUTION!

The Chargemaster is not protected against:

- reversing polarity of the DC-output,
- three phase AC on the AC-input.

## 4 INSTALLATION

During installation and commissioning of the Chargemaster, the important safety instructions are applicable at all times. See chapter 2 of this manual.

### 4.1 UNPACKING

In addition to the Chargemaster the delivery includes:

- a mounting bracket to mount the chargemaster to a wall;
- a battery temperature sensor;
- a MasterBus terminating device (see chapter 6);
- the installation manual

After unpacking, check the contents for possible damage. If in doubt, contact your supplier.

Check from the identification label (see section 1.4) whether the battery voltage is the same as the nominal output voltage of the Chargemaster (e.g. 24V battery set for a 24V battery charger).

### 4.2 ENVIRONMENT

Obey the following stipulations during installation:

- The Chargemaster is designed for indoor use only.
- Ambient temperature: 0 ... 60°C / 32°F ... 140°F; (power derating above 40°C / 104 °F to decrease the internal heat sink temperature).
- Humidity: 0-95% non condensing.
- Mount the Chargemaster vertically, with the connecting cables downwards.
- Make sure that the hot air that is developed during operation can be discharged. The Chargemaster must be mounted in such a way that obstruction of the airflow through the ventilation openings will be prevented.
- No objects must be located within a distance of 10 cm / 4 inch around the Chargemaster.
- Do not locate the Chargemaster in the same compartment as the batteries.
- Do not install the Chargemaster straight above the batteries because of possible corrosive sulphur fumes.

### 4.3 WIRING AND BATTERIES



#### WARNING!

The wire and fuse sizes stated in this manual are given as example only. Prescribed wire and fuse sizes may be different due to local applicable regulations and standards.

#### 4.3.1 AC wiring

For a safe installation the correct wire cross section must be applied. Don't use a cross section that is smaller than indicated. See table below to select the appropriate cross section for the AC wiring (up to 2m / 6ft length):

AC Current	Minimum cross section:	
	in mm <sup>2</sup>	AWG
4-6 A	1.0 mm <sup>2</sup>	17
6-12 A	1.5 mm <sup>2</sup>	15

Connection of AC-wiring and recommended wire colours

- 230V/50Hz installations:

Wire color	Meaning	Connect to:
Brown or black	Phase	L1
Blue	Neutral	N
Green/Yellow	Earth	PE / GND

- 120V/60Hz installations (single phase):

Wire color	Meaning	Connect to:
Black	Hot or Line	L1
White	Neutral	N
Green	Ground	PE / GND

#### 4.3.2 DC wiring

Keep in mind that high current will pass through the DC wiring. Keep the cable length as short as possible, this will keep the system efficiency as high as possible. The recommended minimum cross section of the battery cables for output 1, 2 and 3 is:

Model	DC Cable cross section:	
	<2m / 6ft	2-5m / 6ft
12/35-3	16mm <sup>2</sup> / 4AWG	25mm <sup>2</sup> / 2AWG
12/50-3	25mm <sup>2</sup> / 2AWG	35mm <sup>2</sup> / 1AWG
24/20-3	10mm <sup>2</sup> / 6AWG	16mm <sup>2</sup> / 4AWG
24/30-3	16mm <sup>2</sup> / 4AWG	25mm <sup>2</sup> / 2AWG

Use ring terminals on the ends of the wires. The terminals must be crimped with a proper crimping tool. Use the following wire colours for DC wiring colour or at least different colours to make a clear distinction between the positive and negative wire from the battery:

Wire color	Meaning	Connect to:
Red	Positive	+ (POS)
Black	Negative	- (NEG)

Lay the positive and negative cables next to each other to limit the electro magnetic field around the cables. The negative cable should be connected directly to the

negative post of the battery bank or the ground side of a current shunt. Do not use the chassis frame as the negative conductor. Tighten securely. The positive battery cable must be fused and connected to the positive post of the battery bank.

Main charge outputs 1, 2 & 3

Model Chargemaster	Recommended charger fuse
12/35-3	40A
12/50-3	63A
24/20-3	32A
24/30-3	40A

The fuse with the fuse-holder is available from your local Mastervolt distributor or Customer Service Representative, see chapter 9 Ordering information.

### 4.3.3 Battery capacity

The minimum required battery capacity is as follows:

Model Chargemaster	Minimum required battery capacity
12/35-3	70-350Ah
12/50-3	100-500Ah
24/20-3	50-250Ah
24/30-3	70-350Ah

### 4.3.4 AC safety grounding



#### WARNING!

The ground wire offers protection only if the cabinet of the Chargemaster is connected to the safety ground. Connect the ground terminal (PE / GND) to the hull or the chassis.



#### CAUTION!

For safe installation it is necessary to Insert a Residual Current Device (earth leakage switch) in the AC input circuit of the Chargemaster.

## 4.4 OVERVIEW CONNECTION COMPARTMENT

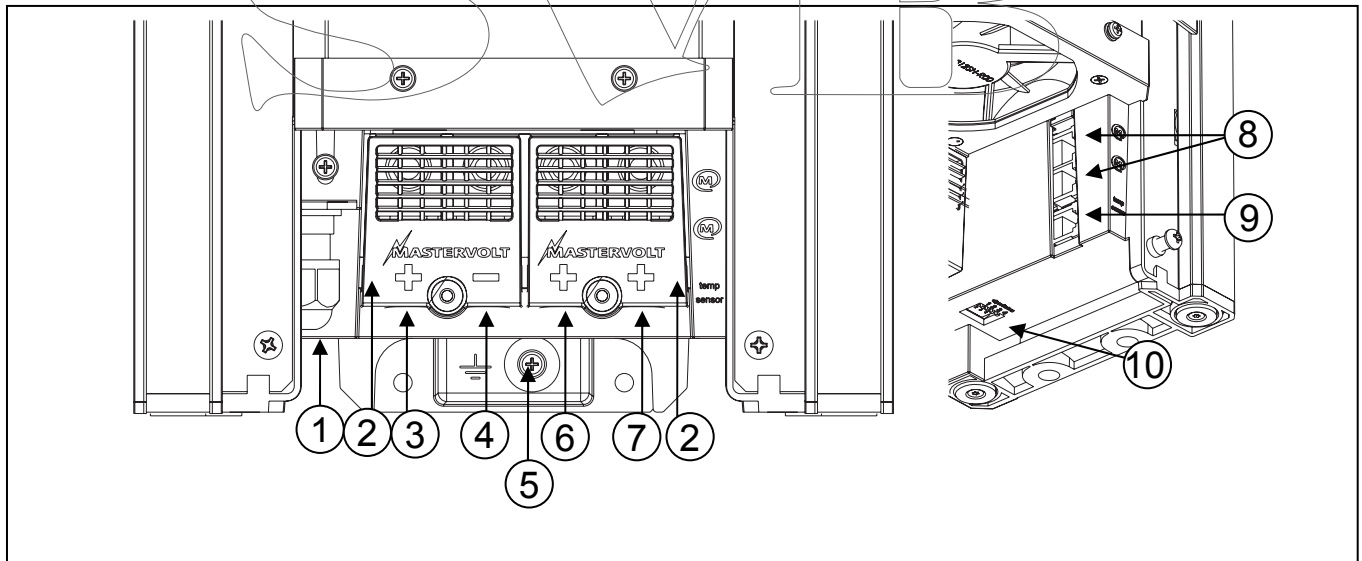

Figure 5: Overview connection compartment

1. Cable gland for AC-wiring
2. Isolation caps for DC connections
3. Positive terminal charge output 1
4. Common negative output terminal
5. Common ground connection
6. Positive terminal charge output 2
7. Positive terminal charge output 3
8. MasterBus connectors
9. Temperature sensor jack
10. DIP switches

### 4.5 THINGS YOU NEED

Make sure you have all the parts you need to install the Chargemaster:

	Quantity
Chargemaster (included)	1
Battery temperature sensor with cable and plug (included).	1
DC cable to connect the positive DC connection (+) of the Chargemaster to the positive pole of the DC-distribution; for specifications see section 4.3.2.	1
DC-cable to connect the negative DC connection (-) of the Chargemaster to the negative pole of the DC-distribution; for specifications see section 4.3.2.	1
DC-fuse holder with a DC-fuse, to be integrated in the positive DC-cable. For specifications see section 4.3.2.	1
Screws / bolts (Ø 6mm) (with plugs) to mount the cabinet to a surface. Use mounting materials which are suitable to carry the weight of the Chargemaster	4
AC cable* to connect the AC input to an external power source (e.g. a shore connection or a generator set);	1
Batteries. See section 4.3.3 for recommended capacity	X
Appropriate and reliable cable terminals, cable lugs, battery terminals and cord end terminals	X

\* Double insulated three wire cable with wire colours according to the locally applicable regulations. The applicable length and wire diameter depend on the electrical installation (see section 4.3.1).

We recommend as a minimum tool kit:

- Socket wrench 10mm to fix the DC-input (battery) cables
- Flat blade screw driver 1.0 x 4.0 mm to fix the screw terminals
- Tools to fix the screws / bolts (Ø 6mm) with plugs to mount the cabinets to a surface
- Philips screw driver to open the connection area of the Chargemaster

### 4.6 CONNECTION



**WARNING**

Let installation work be done by a licensed electrician. Before beginning with the connection of the wiring, make the AC distribution as well as the DC distribution voltage free.



**CAUTION!**

Short circuiting or reversing polarity may lead to serious damage to the batteries, the Chargemaster, the cabling and/or the terminal connections. Fuses between the batteries and the Chargemaster can not prevent damage caused by reversed polarity. The damage as a result of reverse polarity is detectable by the service department and is not covered by the warranty.



**CAUTION!**

Too-thin cables and/or loose connections can cause dangerous overheating of the cables and/or terminals. Therefore tighten all connections well, in order to limit transition resistance as far as possible. Use cables of the correct size.



**NOTE:**

If the battery temperature remains within 15-25°C, connection of the battery temperature sensor is optional.



**NOTE:**

The Chargemaster is only feasible for the connection of MasterBus compatible remote control panels.

4.6.1 Connection example

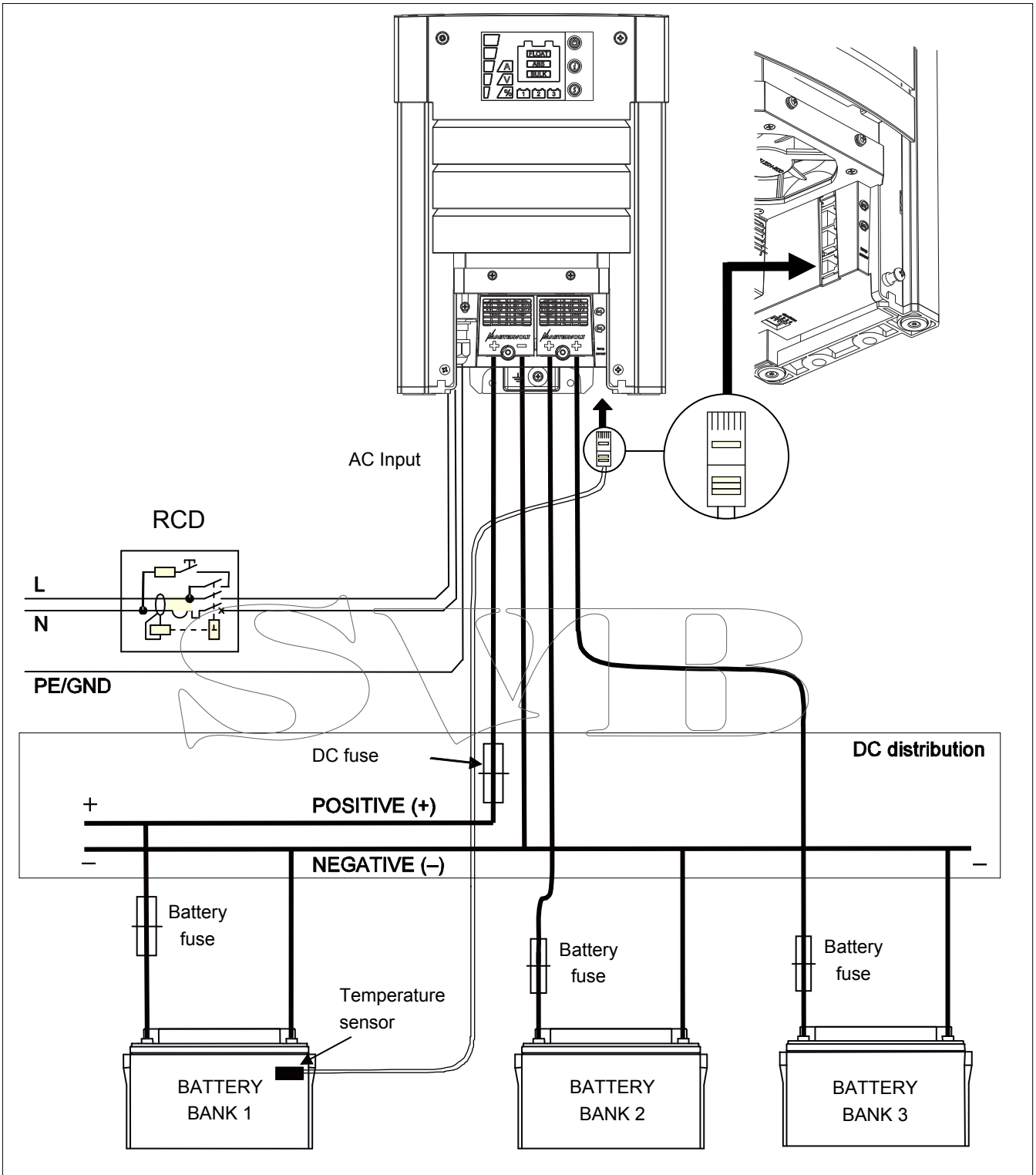

This schematic is to illustrate the general placement of the Chargemaster in a circuit. It is not meant to provide detailed wiring instructions for any particular electrical installation.

Figure 6: installation drawing of the Chargemaster

## 4.7 INSTALLATION STEP BY STEP

For the ChargeMaster step by step installation, see the Installation manual (included in delivery).

## 4.8 COMMISSIONING AFTER INSTALLATION



If your ChargeMaster is not new, you have to take into account that former users may have changed the settings. Reset the ChargeMaster to factory settings when there is any doubt (see section 6.3.).

### 4.8.1 General

The factory settings of the ChargeMaster are optimal for most installations. With some applications however, it is desirable to change these settings. Therefore several adjustments can be made. See chapter 5.



**NOTE:**  
The DIP-switches must be adjusted *prior* to commissioning; all other settings can only be made *after* commissioning.



**CAUTION!**  
Check the polarity of all wiring before commissioning: positive connected to positive (red cables), negative connected to negative (black cables).

If all wiring is OK, place the DC-fuse(s) of the DC-distribution to connect the batteries to the ChargeMaster.



**WARNING**  
When placing this fuse, a spark can occur, caused by the capacitors used in the ChargeMaster. This is particularly dangerous in places with insufficient ventilation, due to the gassing of the batteries an explosion can occur. Avoid having flammable materials close by.

Now the ChargeMaster is ready for operation. After switching on the AC power supply the ChargeMaster will initiate the charging process.

### 4.8.2 MasterBus

During first commissioning the ChargeMaster will be recognized by the MasterBus network automatically. The remote control panel of the MasterBus network will indicate that a new device was found.

Some settings can only be changed via the MasterBus interface. See section 6.3 for an overview of all available MasterBus settings. Refer to the user's manual of the remote control panel to change these settings.

## 4.9 DECOMMISSIONING

If it is necessary to put the ChargeMaster out of operation, follow the instructions in order of succession as described below:

- 1 Switch the ChargeMaster to stand-by (see section 3.2).
- 2 Remove the DC-fuse(s) of the DC-distribution and/or disconnect the batteries.
- 3 Remove the AC-fuse(s) of the AC-input and/or disconnect the AC-mains.
- 4 Open the connection compartment of the ChargeMaster.
- 5 Check with a suitable voltage meter whether the inputs and the outputs of the ChargeMaster are voltage free.
- 6 Disconnect all the wiring.

Now the ChargeMaster can be demounted in a safe way.

## 4.10 STORAGE AND TRANSPORTATION

When not installed, store the ChargeMaster in the original packing, in a dry and dust free environment.

Always use the original packing for transportation. Contact your local Mastervolt Service Centre for further details if you want to return the apparatus for repair.

## 4.11 RE-INSTALLATION

To reinstall the ChargeMaster, follow the instructions in the installation manual.

## 5 SETTINGS

Adjustment of the settings of the ChargeMaster can be made in two different ways:

- By means of DIP-switches; see section 5.1;
- Via the MasterBus network (by means of a remote control panel or an interface connected to a PC with MasterAdjust software); see section 6.3.



### CAUTION!

Invalid settings of the ChargeMaster can cause serious damage to your batteries and/or the connected load! Adjustments of settings may be undertaken by authorised personnel only.

### 5.1 DIP SWITCH SETTINGS

The ChargeMaster has four DIP switches at the bottom side of the housing. See figure 7. DIP switch 3 is without function.

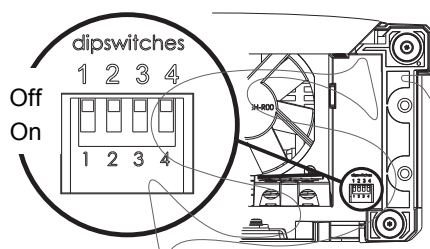

Figure 7: DIP switches

#### 5.1.1 DIP switch 1: Battery type

The factory default for the battery type is optimal for most installations. In some applications however, it is desirable to change this setting.

Wet battery (factory setting)	OFF
Gel / AGM / spiral battery (see specifications)	ON

#### 5.1.2 DIP switch 2: Charge algorithm

IUoUo, fully automatic / 3step+ (factory setting)	OFF
Constant voltage charging (Float = 13.25/26.5V)	ON

#### 5.1.3 DIP-switch 3: Stand-by mode for display

Display will switch off when Chargemaster is switched to stand-by mode (factory setting)	OFF
Display will stay on when Chargemaster is switched to stand-by mode. Note that the display is powered by the batteries.	ON



### WARNING

Incorrect use of the equalize mode may lead to hazardous situations.

Do not smoke; use any naked flame or other sources of ignition due to risk of explosion. Always ventilate the room where the batteries are located and equalized to clear the air.

Equalization is ONLY applicable for wet type batteries and will damage gel and AGM type batteries.

An equalizing charge can be necessary after very deep discharges and/or inadequate charges. This has to be carried out according to the specifications of the manufacturer of the batteries.

During equalizing the batteries are brought into the gas state and it is possible that the permitted load voltages are exceeded. Therefore appropriate measures must be taken, e.g. disconnect all loads from the battery and ventilate the room. For these reasons use of the equalizing mode should only be executed by trained technical engineers.

The equalizing mode can only be started when the Chargemaster is in operation and in Float. This means that the connection compartment of the Chargemaster must be opened while connected to the mains and the batteries. Take adequate measures for protection against short circuits and electrical shocks.

To start the equalize mode: move DIP switch 4 to the ON position and back to the OFF position.

## 6 MASTERBUS

### 6.1 WHAT IS MASTERBUS?



All devices that are suitable for MasterBus are marked by the MasterBus symbol.

MasterBus is a fully decentralized data network for communication between the different Mastervolt system devices. It is a CAN-bus based communication network which has proven a reliable bus-system in automotive applications. MasterBus is used as power management system for all connected devices, such as the inverter, battery charger, generator and many more. This enables communication between the connected devices, for instance to start the generator when the batteries are low.

MasterBus reduces complexity of electrical systems by using UTP patch cables. All system components are simply chained together. The results are a reduction of material costs as only a few electrical cables are needed and less installation time.

For central monitoring and control of the connected devices Mastervolt offers a wide range of panels which show full status information of your electrical system at a

glance and a push of a button. All monitoring panels can be used for monitoring, control and configuration of all connected MasterBus devices.

New devices can be added to the existing network in a very easy way by just extending the network. With this the MasterBus network offers a high degree of flexibility for extended system configuration, not only today, but in the future as well!

Mastervolt also offers several interfaces, making even non-MasterBus devices suitable to operate in the MasterBus network.

For direct communication between the MasterBus network and a product which is not from Mastervolt, the Modbus interface is recommended.



**CAUTION:** Never connect a non-MasterBus device to the MasterBus network directly! This will void warranty of all MasterBus devices connected.

The *event* configuration of the ChargeMaster as target and as source is described in chapter 6 of this manual.

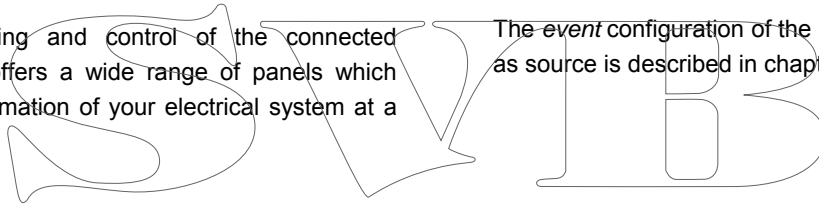



## 6.2 HOW TO SET UP A MASTERBUS NETWORK

Every device suitable for the MasterBus network is equipped with two data ports. When two or more devices are connected by these ports, they form a local data network, called the MasterBus.

Keep the following rules in mind:

Connections between the devices are made by standard straight UTP patch cables. Mastervolt can supply these cables. These cables are also commonly available at computer supply stores.

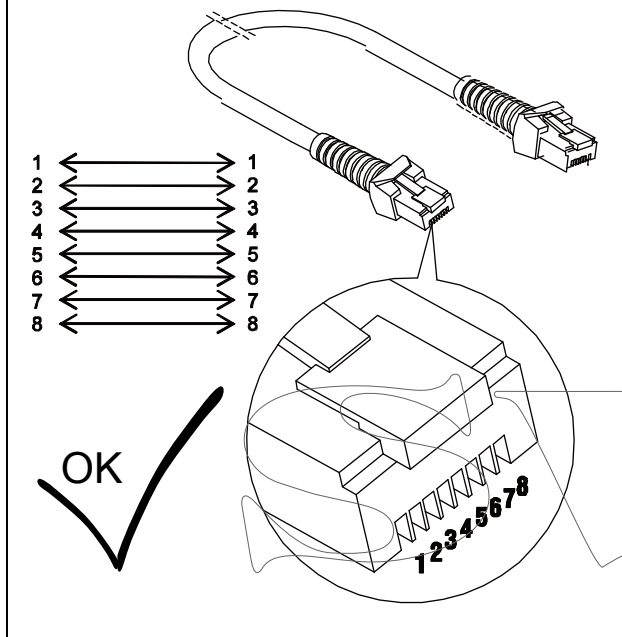

Figure 8

As with all high speed data networks, MasterBus needs a terminating device on both ends of the network.

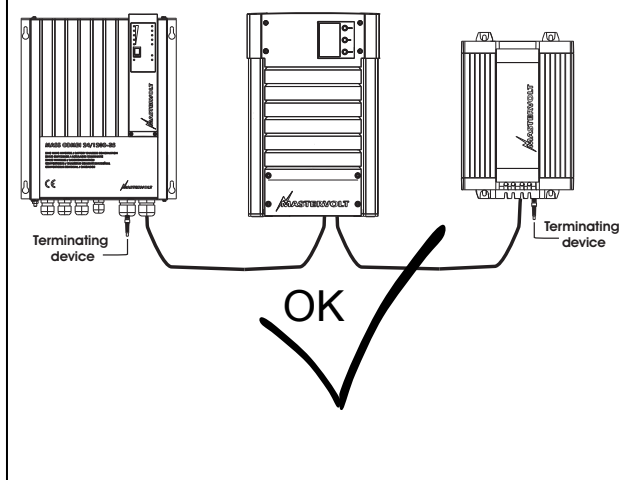

Figure 9

The connected devices provide the electric power for the network. At least one device in the network should have powering capabilities (see specifications). One powering device can power up to three non-powering devices. As all powering devices are galvanically isolated, multiple powering devices are allowed.

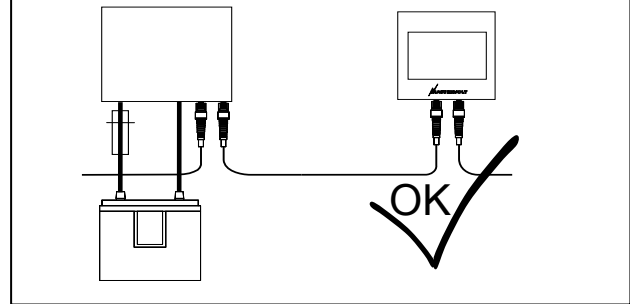

Figure 10

Do not make ring networks

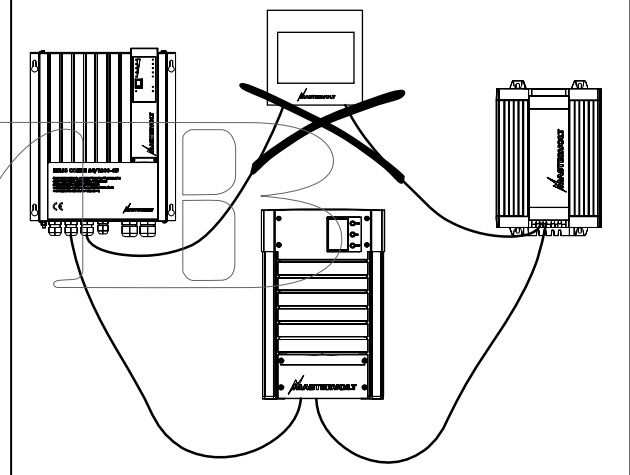

Figure 11

Do not make T-connections in the network.

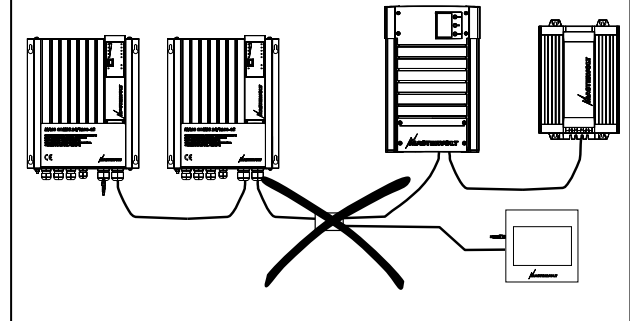

Figure 12

### 6.3 MASTERBUS: MONITORING AND PROGRAMMING OF THE CHARGEMASTER

#### 6.3.1 Monitoring

Value	Meaning
State	Shows charger state (Charging/ Stand by)
Max input power	Option to set the maximum current at the input to prevent generator or shore fuse overload
Charger status	State of charge algorithm: Bulk/ absorption/ float
House bank	Voltage of charger output 1*
Charge current	Total charge current*
House bank	Temperature of battery 1
Output 2	Voltage of charger output 2*
Output 3	Voltage of charger output 3*
AC input	AC input voltage
State	Option to switch on/ off the ChargeMaster
<i>System</i>	
Connect to Shunt	A connected MasterShunt can be chosen for feedback on the charged battery.
MasterShunt....	Information on the MasterShunt linked to the ChargeMaster.

#### 6.3.2 Alarms

Value	Meaning	Factory setting	Adjustable range
Low batt	Battery voltage has dropped below setting <i>DC low on</i> , and has not increased above setting <i>DC low off yet</i>	See 6.3.4	See 6.3.4
High batt	Battery voltage has increased above setting <i>DC high on</i> , and has not dropped below setting <i>DC high off yet</i>	See 6.3.4	See 6.3.4
Low AC	AC input voltage is too low	90V / 180V*	n/a
High AC	AC input voltage is too high	135V / 265V*	n/a
Low frequency	AC input frequency is too low	45Hz	n/a
High frequency	AC input frequency input is too high	65Hz	n/a
High temperature	Internal temperature is too high	70°C (176°F)	n/a
Low temperature	Internal temperature is too low	-20°C (-4°F)	n/a
Temp sense error	Temperature sensor is in failure		
MSH out of range	The values the MasterShunt transmits exceed the limits.		

\* See section 8.4, figure 10 for characteristics

#### 6.3.3 History

This menu shows the total historical readings (read only).

Value	Meaning
<i>Charger</i>	
Charge cycles	Number of completed cycles
Charge cycles	Number of aborted charge cycles
Ah charged	Total Ampere hours charged
Total run time	Total run time in charger mode
Highest AC volt	Highest AC input voltage
Temperature	Number of temperature shutdowns
Low DC	Number of low DC voltage shutdowns
High DC	Number of high DC voltage shutdowns
High AC	Number of high AC voltage shutdowns
Low AC	Number of low AC voltage shutdowns
<i>House bank</i>	
Lowest voltage	Lowest detected DC voltage output 1
Highest voltage	Highest detected DC voltage output 1
<i>Output 2</i>	
Lowest voltage	Lowest detected DC voltage output 2
Highest voltage	Highest detected DC voltage output 2
<i>Output 3</i>	
Lowest voltage	Lowest detected DC voltage output 3
Highest voltage	Highest detected DC voltage output 3
<i>System</i>	
Last MPC from: Select...	The latest Maximum Power Control-command the ChargeMaster received as event target, see section 6.3.6. This value shows what device controlled/ reduced the ChargeMaster.

## 6.3.4 Configuration

Below parameters can be changed via the MasterBus network by means of a remote control panel or by means of an interface connected to a PC with MasterAdjust software. See applicable user's manuals for details.

Value	Meaning	Factory setting	Adjustable. range
<i>General</i>			
Language	Language displayed on a MasterBus monitoring device	English	See specifications
Product name	Name of this device. This name will be recognized by all devices connected to the MasterBus.	CHG CM+type*	0-12 chars
Output 1	Name of output 1 in the MasterBus network	House bank	12 characters max
Output 2	Name of output 2 in the MasterBus network	Output 2	12 characters max
Output 3	Name of output 3 in the MasterBus network	Output 3	12 characters max
Factory settings	Button to reset the ChargeMaster to factory settings		
<i>Charge current</i>			
AC load	Select the method to reduce the AC input power	Auto	Auto, MPC, manual
Maximum current	Set the maximum charging current allowed	Model depend.	Model dependent
<i>System</i>			
System behaviour	Set the use mode. The ChargeMaster can be synchronized with other MasterBus chargers.	System behaviour	Set the use mode. The ChargeMaster can be synchronized with other MasterBus chargers.
MasterShunt	Select the MasterShunt that provides the ChargeMaster with battery information.	MasterShunt	Select the MasterShunt that provides the ChargeMaster with battery information.
<i>Bulk</i>			
Bulk voltage	Bulk voltage	14.40/28.80V	0-15.50/0-31.00V
Max. bulk timer	Maximum bulk timer	8h	0-24h
Min bulk timer	Minimum bulk timer	120sec	0-240sec
Start bulk timer	Start bulk timer	13.25/26.50V	(read only)
<i>Absorption</i>			
Abs. voltage	Absorption voltage	14.25/28.50V	0-15.50/0-31.00V
Max absorption	Maximum absorption timer	4h	0-24h
Min absorption	Minimum absorption timer	15min	0-240min
Return amps	Return amps (% of maximum charge current)	6%	0-50%
Return amps tim	Return amps timer	30sec	0-240sec.
<i>Float settings</i>			
Float voltage	Float voltage	13.25/26.50V	0-15.50/0-31.00V
Forced float vo.	Forced float voltage (Constant voltage charging)	13.25/26.50V	0-15.50/0-31.00V
Return to bulk	Return to bulk voltage	12.80/25.60V	0-15.50/0-31.00V
Return to bulk	Return to bulk time delay	30sec	0-240sec
<i>Alarms</i>			
DC high on	Alarm DC High on	16.00/32.00V	0-16.00V0-32.00V
DC high off	Alarm DC High off	15.00/30.00V	0-16.00V0-32.00V
DC low on	Alarm DC low on	10.00/20.00V	0-16.00/0-32.00V
DC low off	Alarm DC low off	11.00/22.00V	0-16.00/0-32.00V
Alarm delay	Alarm delay time	30sec	0-240sec
<i>Traction</i>			
Traction Bulk v	Traction bulk voltage	+300/+600mV	(read only)
Traction Absorpt	Traction absorption voltage	+300/+600mV	(read only)
Traction absorpt	Traction absorption timer	8 hrs	(read only)
<i>Equalization</i>			
Equalize voltage	Equalize voltage float	+2.25/+4.50V	(read only)
Max equalize tim	Max equalize timer	480 min	(read only)
<i>DIP-switches</i>			
Battery type	Setting for AGM/Gel batteries. Off = Wet battery, On = AGM/Gel	Off	Off, On**
Charge algorithm	12V/24V power supply allowed. Off=no, On=yes	Off	Off, On**
Display mode	Display off saves batteries. Off=no, On=yes	Off	Off, On**

Value	Meaning	Factory setting	Adjustable. range
Equalize mode	Equalize is suitable FOR WET BATTERIES ONLY!. Off=no, On=yes	Off	Off, On**
<b>Events</b>			
Event x source	Event by the ChargeMaster that should result in an action by one of the other devices on the MasterBus network. Nine events are available: x can be 1-9.	Disabled	See section 6.3.5 Event source list
Event x target	Select a connected MasterBus device that should take action due to a ChargeMaster event.	Select...	Selectable targets are system dependent.
Event x command	Action to be taken by the target device.	Select...	See command list in manual of the selected device. Chargemaster section 6.3.6.
Event x data	Data is linked to the command. See also figure 13.	Off	Off, On, Copy, Copy Invert, Toggle.
Event x+1	The next event appears after enabling Event x.	Disabled	See Event x.

\* Depending on model: CM12/35, CM12/50, CM24/20, CM24/30

\*\* Read only via MasterBus

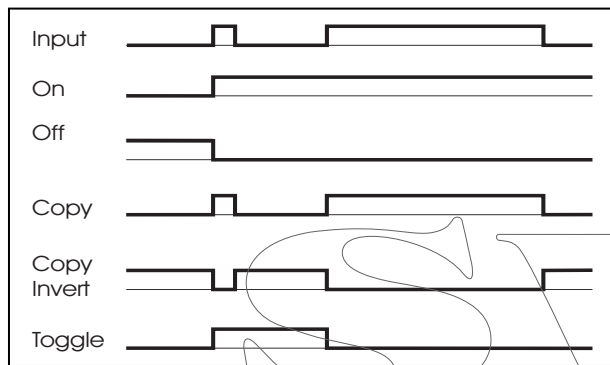

Figure 13: Event data

Figure 13 shows the meaning of the event data. **Input** is a pulse followed by a longer signal (1/0). **On** changes the status to On at the first signal. **Off** changes the status to Off at the first signal. **Copy** lets the status follow the input.

**Copy Invert** lets the status follow the opposite of the input. **Toggle** changes the status at the first signal and back at the second signal. It is often used in combination with a pulse switch.

### 6.3.5 ChargeMaster 1 event source list (ChargeMaster as event source)

On	ChargeMaster state is On
Bulk	State of charge is Bulk
Abs	State of charge is Absorption
Float	State of charge is Float
Failure	Charger failure MasterBus alarm
CSI	Charger Status Interface MasterBus alarm to sound a horn at charger failure
Equalize	ChargeMaster is in Equalize mode
Fan	MasterBus signal for an external fan to start (at 50% load / 50°C)
Led 1	Bottom yellow LED of the MasterView Read Out illuminates (see manual MasterView Read Out)
Led 2	2nd yellow LED from bottom of the MasterView Read Out illuminates (see manual MasterView Read Out)
Led 3	3rd yellow LED from bottom of the MasterView Read Out illuminates (see manual MasterView Read Out)
Led 4	4th yellow LED from bottom of the MasterView Read Out illuminates (see manual MasterView Read Out)
Led 5	Top yellow LED of the MasterView Read Out illuminates (see manual MasterView Read Out)

### 6.3.6 ChargeMaster event target list (ChargeMaster as event target)

Mpc reduce power	Command to reduce AC current at a 5%/sec rate
Mpc stop	Command to reduce AC current fast
Bulk	Command to start the Bulk state of charge
Abs	Command to start the Absorption state of charge
Float	Command to start the Float state of charge
State	Command to switch on the ChargeMaster

## 7 TROUBLE SHOOTING

If you cannot solve a problem with the aid of this chapter, contact your local Mastervolt Service Centre. See [www.mastervolt.com](http://www.mastervolt.com). Make sure you have the following information present if you have to contact your local Mastervolt Service Center to solve a problem:

- Article and serial number (See section 1.4)
- Software version (See section 6.3.3)

### 7.1 FAULT FINDING TABLE

Malfunction	Possible cause	What to do
No output voltage and/or current	No AC-input	Check AC wiring, check remote control panel.
	AC-input voltage too low (< 90VAC)	Check input voltage, check generator.
	AC input frequency out of range	Check input voltage, check generator.
Output voltage too low, charger supplies maximum current	Load that is connected to the batteries is larger than charger can supply.	Reduce load taken from the batteries.
	Batteries not 100% charged	Measure battery voltage. After some time this will be higher.
Charge current too low	Batteries almost fully charged	Nothing, this is normal when the battery is almost fully charged.
	High ambient temperature	Nothing; if ambient temperature is more than the setting limit the charge current is automatically reduced.
	Low AC input voltage. At lower AC input voltages the charge current is reduced. See figure 15.	Check AC-input voltage.
Batteries not fully charged	Charge current too low	See "Charge current too low" in this table.
	Current to load is too high	Reduce load taken from the batteries.
	Charge time too short	Use a battery charger with higher capacity.
	Battery temperature too low	Use the battery temperature sensor.
	Defective or old battery	Check battery and replace if necessary.
Batteries are discharged too fast	Battery capacity reduced due to wastage or sulphation, stagnation	Charge and recharge a few times, this might help. Check battery and replace if necessary.
Batteries are too warm, gassing	Defective battery (short circuit in cell)	Check battery and replace if necessary.
	Battery temperature too high	Use the battery temperature sensor.
	Charge voltage too high	Check settings (see section 6.3.4).
No MasterView display function.	Display is switched off.	Switch on display, refer to display manual.
	Error in the wiring.	Check the MasterBus cables.
Slow or no MasterBus communication.	Error in the MasterBus wiring.	Check the MasterBus cables.
	No terminating device placed at the ends of the network.	MasterBus needs a terminating device on both ends of the network. Check if connected (see section 6.2).
	MasterBus network is configured as a ring network.	Ring networks are not allowed. Check the connections of the network (see section 6.2).
MasterView Easy panel connected to the ChargeMaster, no communication.	The Easy panel has been switched off or MasterBus is not working correctly.	Check MasterBus wiring, a terminator should be placed on both ends of the MasterBus network.

## 8 TECHNICAL DATA

### 8.1 SPECIFICATIONS 12V MODELS

Model	12/35-3	12/50-3
Article no.	44010350	44010500
<b>GENERAL</b>		
Nominal input voltage:	120/230V	120/230V
Nominal input frequency:	50/60Hz	50/60Hz
Full load consumption:	575VA	825VA
Efficiency at full load (230V AC):	≥81% @ 230V input	≥81% @ 230V input
Nominal output voltage:	12V	12V
Total maximum charge current*:	35A at 14.4V	50A at 14.4V
Number of battery outputs:	3	3
Output voltage range adjustable	0 to 16V DC	0 to 16V DC
Charge characteristic*:	IUoUo, automatic, three step plus	IUoUo, automatic, three step plus
Charge voltage Bulk*:	14.4V	14.4V
Charge voltage Absorption*:	14.25V	14.25V
Charge voltage Float*:	13.25V	13.25V
Max. absorption and max. bulk timer*:	8 hours (start max. bulk timer at 13.25V)	8 hours (start max. bulk timer at 13.25V)
Minimum absorption time*:	15 min.	15 min.
Battery type settings*:	Wet battery/ gel/ traction/ AGM / spiral (adjustable by means of DIP-switch)	Wet battery/ gel/ traction/ AGM/ spiral (adjustable by means of DIP-switch)
Dimensions in mm (inch):	291x210x131 (11.5x8.3x5.2)	291x210x131 (11.5x8.3x5.2)
Weight:	4kg (9Lbs)	4kg (9Lbs)
Recommended battery capacity:	70-350Ah	100-500Ah
Power factor regulations	≤ 0.99	≤ 0.99
Temperature compensation	Battery temperature sensor and cable included.	Battery temperature sensor and cable included.
Voltage compensation	Yes, by means of automatic compensation.	Yes, by means of automatic compensation.
DC consumption	<5mA	<5mA
Temperature range	-25°C (-13°F) to 65°C (149°F). derating 3%/°C (2%/°F) above 40°C (104°F) , 90% derating under 0°C (32°F)	-25°C (-13°F) to 65°C (149°F). derating 3%/°C (2%/°F) above 40°C (104°F) , 90% derating under 0°C (32°F)
Cooling	Vario fan and natural cooling to ensure optimized cooling when unit stored in corners etc.	Vario fan and natural cooling to ensure optimized cooling when unit stored in corners etc.
Sound level	<52dBA / 1m	<52dBA / 1m
Protection degree	IP23	IP23
Approvals	Fully CE and E-marking according to automotive directive 95/54/EG / UL pending	Fully CE and E-marking according to automotive directive 95/54/EG / UL pending
MasterBus connectivity	Yes	Yes
Powering capabilities for MasterBus	Yes, when the charger is switched on, it can power up to three non-powering devices.	Yes, when the charger is switched on, it can power up to three non-powering devices.
MasterBus languages available	English	English

\* Adjustable, see chapter 5 for settings.

Specifications are subject to change without prior notice.

## 8.2 SPECIFICATIONS 24V MODELS

Model	24/20-3	24/30-3
Article no.	44020200	44020300
<b>GENERAL</b>		
Nominal input voltage:	120/230V	120/230V
Nominal input frequency:	50/60Hz	50/60Hz
Full load consumption:	660VA	925VA
Efficiency at full load:	≥83% @ 120V input	≥85% @ 230V input
Nominal output voltage:	24V	24V
Total maximum charge current*:	20A at 28.8V	30A at 28.8V
Number of battery outputs:	3	3
Output voltage range adjustable	10-32VDC	10-32VDC
Charge characteristic*:	IUoUo, automatic, three step plus charging method	IUoUo, automatic, three step plus charging method
Charge voltage Bulk*:	28.8V	28.8V
Charge voltage Absorption*:	28.5V	28.5V
Charge voltage Float*:	26.5V	26.5V
Max. absorption and max. bulk timer*:	8 hours (start of the maximum bulk timer at 26.5V)	8 hours (start of the maximum bulk timer at 26.5V)
Minimum absorption time*:	15 min.	15 min.
Battery type settings*:	Wet battery / gel / traction / AGM / spiral (adjustable by means of DIP-switch)	Wet battery / gel / traction / AGM / spiral (adjustable by means of DIP-switch)
Dimensions in mm (inch):	291x210x131 (11.5x8.3x5.2)	291x210x131 (11.5x8.3x5.2)
Weight in kg (pound):	4kg (9Lbs)	4kg (9Lbs)
Recommended battery capacity:	40-200Ah	60-300Ah
Power factor regulations	≤ 0.99	≤ 0.99
Temperature compensation	Battery temperature sensor and cable included.	Battery temperature sensor and cable included.
Voltage compensation	Yes, by means of automatic compensation.	Yes, by means of automatic compensation.
DC consumption	<2.5mA	<2.5mA
Temperature range	-25°C (-13°F) to 65°C (149°F). Derating 3%/°C (2%/°F) above 40°C (104°F), 90% derating under 0°C (32°F)	-25°C (-13°F) to 65°C (149°F). Derating 3%/°C (2%/°F) above 40°C (104°F), 90% derating under 0°C (32°F)
Cooling	Vario fan and natural cooling optimize cooling when unit stored in corners etc.	Vario fan and natural cooling optimize cooling when unit stored in corners etc.
Sound level	<52dBA / 1m	<52dBA / 1m
Protection degree	IP23	IP23
Approvals	Fully CE and E-marking according to automotive directive 95/54/EG / UL pending	Fully CE and E-marking according to automotive directive 95/54/EG / UL pending
MasterBus connectivity	Yes	Yes
Powering capabilities for MasterBus	Yes, when the charger is switched on, it can power up to three non-powering devices.	Yes, when the charger is switched on, it can power up to three non-powering devices.
MasterBus languages available	English	English

\* Adjustable, see chapter 5 for settings

Specifications are subject to change without prior notice.

### 8.3 DIMENSIONS

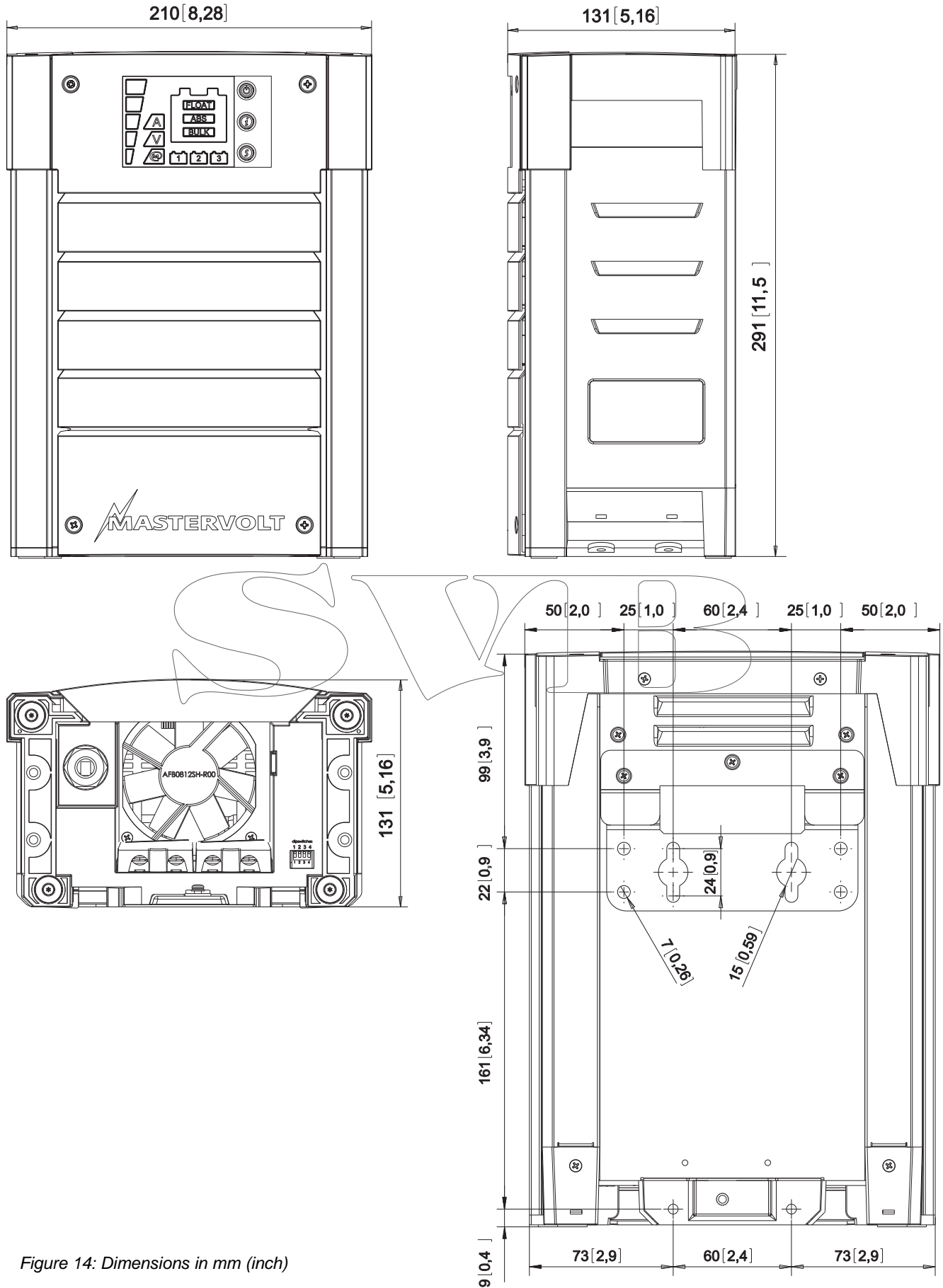

Figure 14: Dimensions in mm (inch)





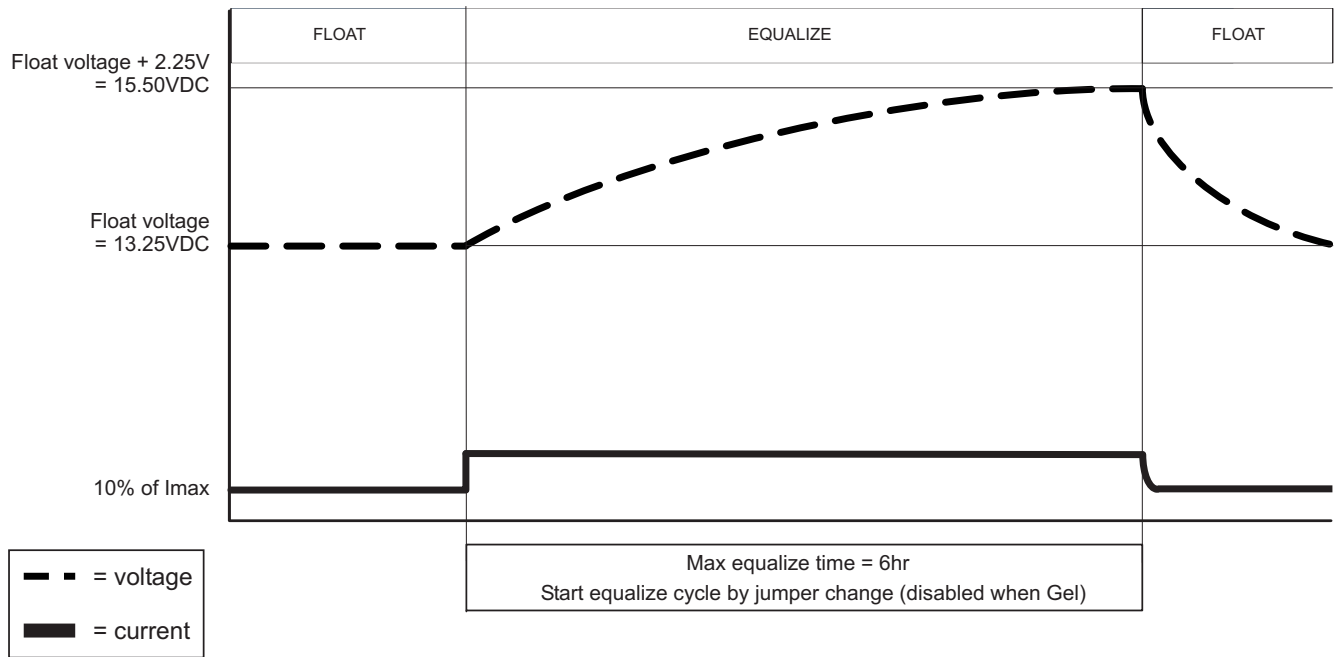

Figure 17: Charge characteristic of the equalize charge cycle (see section 5.1.3) (at 25°C / 77°F)

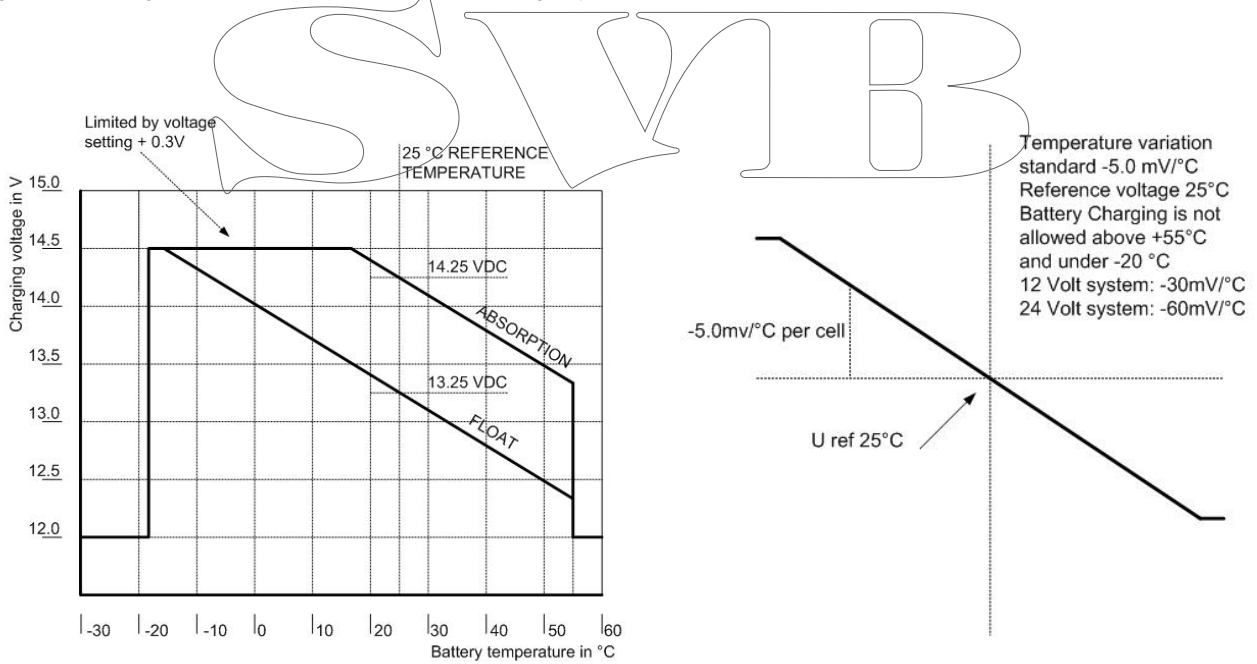

Figure 18: Temperature compensation characteristic (charge voltage versus temperature)

## 9 ORDERING INFORMATION

### 9.1 MASTERBUS INSTALLATION COMPONENTS

Part number	Description
77040000	MasterBus terminating device
77040020	MasterBus connection cable (UTP patch cable), 0,2m / 0.6ft
77040050	MasterBus connection cable (UTP patch cable), 0,5m / 1.6ft
77040100	MasterBus connection cable (UTP patch cable), 1,0m / 3.3ft
77040300	MasterBus connection cable (UTP patch cable), 3,0m / 10ft
77040600	MasterBus connection cable (UTP patch cable), 6,0m / 20ft
77041000	MasterBus connection cable (UTP patch cable), 10m / 33ft
77041500	MasterBus connection cable (UTP patch cable), 15m / 49ft
77042500	MasterBus connection cable (UTP patch cable), 25m / 82ft
77050100	100m / 330ft MasterBus cable (UTP cable)
77050200	50 pcs. modular jacks
77050000	Complete set to assemble UTP patch cables. Delivery includes: 100m / 330ft UTP cable, 50 pcs. modular jacks and crimping tool
77030100	MasterConnect USB interface, required as interface between your PC and the MasterBus when using MasterAdjust software.
77010100	MasterView Classic, Mastervision compatible display to control and monitor all MasterBus products
77010300	MasterView Easy, Touch screen to control and monitor all MasterBus products
77010400	MasterView System, Full-colour touch screen to control and monitor all MasterBus products
77020100	MasterShunt 500, DC-distribution module for exact readout of battery voltage, charge / discharge current, and state of charge on the display of the ChargeMaster, continuous rating: 250A, peak current: 500A

### 9.2 MISCELLANEOUS

Part number	Description
6384003200	Industrial DC fuse 32A DIN 00
6384004000	Industrial DC fuse 40A DIN 00
6384006300	Industrial DC fuse 63A DIN 00
6381001000	Fuse base DIN 00 (max. 160A)
79009006	Battery switch 250A with knob
79009005	Battery switch 250A with key
6387000600	Double pole automatic circuit breaker DPN 6A-B, 1P+N
6387001000	Double pole automatic circuit breaker DPN 10A-B, 1P+N
6387001600	Double pole automatic circuit breaker DPN 16A-B, 1P+N
6385401610	Double pole automatic circuit breaker and earth leakage switch DPN VIGI 16A / B / 16mA, 1P + N
41500500*	Battery temperature sensor, incl. 6 meter / 19 ft cable

\* standard included with the delivery of the Chargemaster

Mastervolt can offer a wide range of products for your electrical installation, including an extended program of components for your MasterBus network, both AGM and gel batteries, shore power connections, DC distribution kits and many more. See our website [www.mastervolt.com](http://www.mastervolt.com) for an extensive overview of all our products.

## 10 EC DECLARATION OF CONFORMITY

Manufacturer Mastervolt  
Address Snijdersbergweg 93  
1105 AN Amsterdam  
The Netherlands

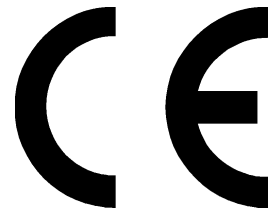

Herewith declares that:

Product:  
44010350 Chargemaster 12/35-3  
44010500 Chargemaster 12/50-3  
44020200 Chargemaster 24/20-3  
44020300 Chargemaster 24/30-3

Is in conformity with the provision of the EC, EMC directive 89/336/EEC and amendments 92/31/EEC, 93/68/EEC.

The following harmonized standards have been applied:

EN 60950-1, EN 55022: 1998+A1: 2000+A2: 2003 Class A  
EN 61000-4-2: 2001, EN 61000-4-4: 2004, EN 61000-4-5: 2001,  
EN 61000-4-3: 2002+A1: 2002, EN 61000-4-6: 1996+A1: 2000,  
EN 61000-3-2: 2000, EN 61000-6-4: 1997,  
LV directive 2006/95/EC

Amsterdam,



P.F. Kenninck,  
General Manager MASTERVOLT

 **MASTERVOLT**

Snijdersbergweg 93, 1105 AN Amsterdam, The Netherlands  
Tel : + 31-20-3422100  
Fax : + 31-20-6971006  
Email : [info@mastervolt.com](mailto:info@mastervolt.com)