

Ray50 / Ray60 / Ray70

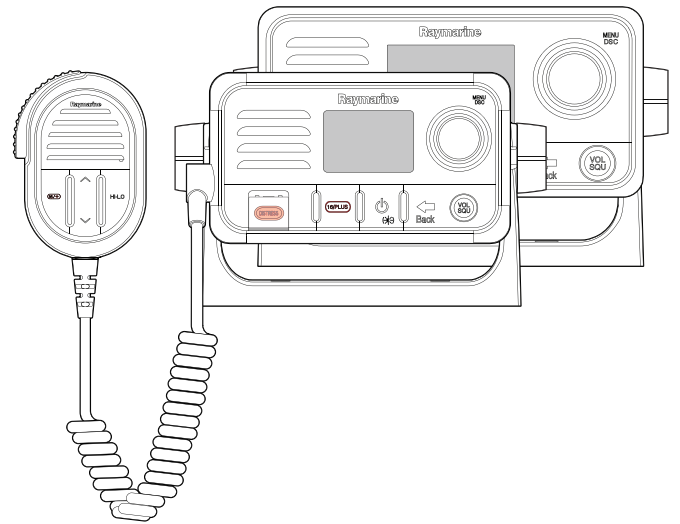

SVR

Installation and operation instructions

English

Date: 03-2015

Document number: 81356-1-EN

© 2015 Raymarine UK Limited

SWIB

Trademark and patents notice

Raymarine, Tacktick, Clear Pulse, Truzoom, HSB, SeaTalk, SeaTalk^{hs}, SeaTalk^{ng}, Micronet, Raytech, Gear Up, Marine Shield, Seahawk, Autohelm, Automagic, and Visionality are registered or claimed trademarks of Raymarine Belgium.

FLIR, DownVision, SideVision, Dragonfly, Instalert, Infrared Everywhere, and The World's Sixth Sense are registered or claimed trademarks of FLIR Systems, Inc.

All other trademarks, trade names, or company names referenced herein are used for identification only and are the property of their respective owners.

This product is protected by patents, design patents, patents pending, or design patents pending.

Fair Use Statement

You may print no more than three copies of this manual for your own use. You may not make any further copies or distribute or use the manual in any other way including without limitation exploiting the manual commercially or giving or selling copies to third parties.

Software updates

Check the website www.raymarine.com for the latest software releases for your product.

Product handbooks

The latest versions of all English and translated handbooks are available to download in PDF format from the website www.raymarine.com.

Please check the website to ensure you have the latest handbooks.

Copyright ©2015 Raymarine UK Ltd. All rights reserved.

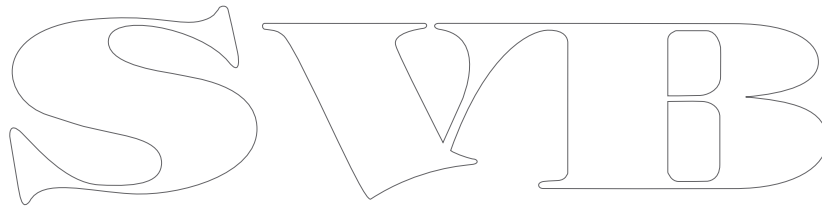

SWIB

Contents

Chapter 1 Important information.....	7	6.9 Switching on the AIS receiver — Ray70	49
Safety notices.....	7	6.10 Selecting a network type.....	50
General Information	8	6.11 Entering your MMSI number.....	50
Chapter 2 Document and product information.....	11	6.12 Enabling and disabling ATIS mode	51
2.1 Document information	12	6.13 Entering your ATIS ID.....	52
2.2 Product information	13	6.14 Changing the radio region.....	53
Chapter 3 Planning the installation	15	6.15 Adjusting the display brightness	53
3.1 Installation checklist	16	6.16 Adjusting the display contrast.....	54
3.2 Parts supplied – Ray50	16	6.17 Switching between high and low transmit power	54
3.3 Parts supplied – Ray60 / Ray70	17	6.18 GPS/GNSS setup.....	55
3.4 Software updates	17	6.19 Station priority - Ray60 and Ray70	56
3.5 Tools required for installation.....	18	Chapter 7 Digital selective calling (DSC).....	57
3.6 System integration — Ray50	19	7.1 Digital Selective Calling (DSC).....	58
3.7 System integration — Ray60 / Ray70	20	7.2 Distress calls	59
3.8 System protocols	21	7.3 Urgency calls.....	61
3.9 General location requirements	22	7.4 Safety calls.....	62
3.10 Mounting options.....	23	7.5 Individual (routine) calls.....	62
3.11 Product dimensions	24	7.6 Group calls	63
Chapter 4 Cables and connections.....	27	7.7 Position requests	64
4.1 General cabling guidance	28	7.8 Phonebook	64
4.2 Connections overview - Ray50	29	7.9 Call logs	65
4.3 Connections overview Ray60 / Ray70	29	7.10 Test calls	65
4.4 Power connection	30	7.11 DSC set-up menu options	66
4.5 Connecting handsets and cables.....	31	Chapter 8 VHF operations	67
4.6 Fistmic connection Ray60 / Ray70	32	8.1 Watch modes.....	68
4.7 SeaTalk^{ng} connection	33	8.2 Scan Mode.....	68
4.8 NMEA 0183 connection.....	34	8.3 Priority channels	69
4.9 Connecting an antenna	34	8.4 Sensitivity	69
4.10 Second handset station — Ray60 / Ray70	35	8.5 Private channels	70
4.11 Passive speaker connection.....	35	8.6 Automatic Transmitter Identification System (ATIS) and Marcom-C mode.....	70
4.12 Loud hailer connection.....	36	8.7 AIS — Ray70	71
Chapter 5 Location and mounting	37	8.8 Set-up menu options	72
5.1 Bracket mounting	38	Chapter 9 Hailer, Fog horn, and Intercom.....	75
5.2 Ray50 Panel mounting	38	9.1 Hailer Fog Intercom menu	76
5.3 Ray60 / Ray70 Panel mounting	40	9.2 Loud Hailer — Ray70	76
5.4 Fistmic / Handset mounting.....	41	9.3 Fog horn.....	77
5.5 Ray60 / Ray70 Raymic handset cradle mounting.....	41	9.4 Intercom — Ray60 and Ray70	77
5.6 Pass-through panel kit mounting	42	Chapter 10 Maintenance	79
Chapter 6 Getting started	43	10.1 Maintenance	80
6.1 Controls and interface	44	10.2 Routine checks	80
6.2 Powering the unit on.....	44	10.3 Product cleaning	81
6.3 Powering the unit off.....	45	10.4 Unit cleaning instructions	81
6.4 Homescreen overview	45	Chapter 11 Troubleshooting	83
6.5 Shortcut list.....	47	11.1 Troubleshooting.....	84
6.6 Initial startup	48	11.2 Performing a system reset	84
6.7 Accessing the menu	48	11.3 System test.....	85
6.8 Selecting a language.....	49	11.4 Power up troubleshooting.....	86

11.5 VHF Radio troubleshooting	87
11.6 GPS troubleshooting.....	88
Chapter 12 Technical support	89
12.1 Raymarine customer support	90
12.2 Viewing product information	90
12.3 Learning resources.....	91
Chapter 13 Technical specification.....	93
13.1 Technical specification — Ray50	94
13.2 Technical specification — Ray60	95
13.3 Technical specification — Ray70	96
13.4 Radio usage	97
Chapter 14 Spares and accessories	99
14.1 Spares.....	100
14.2 Accessories — Ray60 / Ray70	100
14.3 SeaTalk ^{ng} cables and accessories	101
Appendix A NMEA 0183 sentences	103
Appendix B NMEA 2000 PGN List.....	104
Appendix C VHF Channels	105
Appendix D Phonetic alphabet.....	113
Appendix E Prowords	114

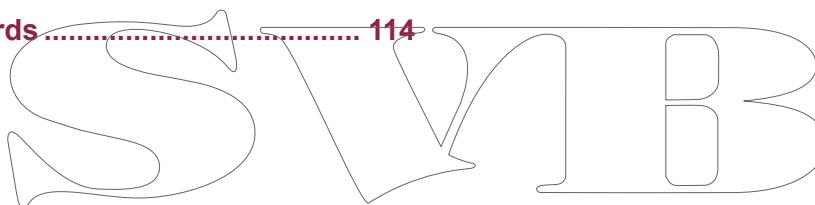

Chapter 1: Important information

Safety notices

Certified Installation

Raymarine recommends certified installation by a Raymarine approved installer. A certified installation qualifies for enhanced product warranty benefits. Contact your Raymarine dealer for further details, and refer to the separate warranty document packed with your product.



Warning: Product installation and operation

This product must be installed and operated in accordance with the instructions provided. Failure to do so could result in personal injury, damage to your vessel and/or poor product performance.



Warning: Potential ignition source

This product is NOT approved for use in hazardous/flammable atmospheres. Do NOT install in a hazardous/flammable atmosphere (such as in an engine room or near fuel tanks).



Warning: 12 Volt dc only

This product must only be connected to a 12 volt dc power source.



Warning: Positive ground systems

Do not connect this unit to a system which has positive grounding.



Warning: Switch off power supply

Ensure the vessel's power supply is switched OFF before starting to install this product. Do NOT connect or disconnect equipment with the power switched on, unless instructed in this document.



Warning: Chassis grounding

Do NOT ground this product using the chassis ground terminal.

Grounding this product to a vessel's RF ground may cause galvanic corrosion.



Warning: Antenna isolation

To prevent galvanic corrosion your antenna must be isolated from any vessel metalwork using a suitable insulated e.g. plastic, mounting bracket.



Warning: FCC Warning (Part 15.21)

Changes or modifications to this equipment not expressly approved in writing by Raymarine Incorporated could violate compliance with FCC rules and void the user's authority to operate the equipment.



Warning: Maximum Permissible Exposure

Failure to observe these guidelines may expose those within the maximum permissible exposure (MPE) radius to RF radiation absorption that exceeds the FCC MPE limit. It is the radio operator's responsibility to ensure that no one comes within this radius.

For optimal radio performance and minimal human exposure to radio frequency electromagnetic energy, make sure the antenna is:

- connected to the radio before transmitting
- located where it will be away from people
- located at least 1.5 meters (5 feet) from the radio's main unit

Caution: Power supply protection

When installing this product ensure the power source is adequately protected by means of a suitably-rated fuse or automatic circuit breaker.

Caution: Perform regular radio checks

Perform regular radio checks when using your vessel, as recommended in radio training and certification schemes and radio equipment rules of use.

Caution: Ensure proper radio use

Under no circumstances should a DSC distress alert be sent from your radio for test purposes. Such action is a violation of rules of use for radio equipment, and can result in heavy fines.

Caution: Product cleaning

When cleaning products:

- If your product includes a display screen, do NOT wipe the screen with a dry cloth, as this could scratch the screen coating.
- Do NOT use abrasive, or acid or ammonia based products.
- Do NOT use a jet wash.

can be determined by turning the equipment off and on, the user is encouraged to try to correct the interference by one of the following measures:

1. Reorient or relocate the receiving antenna.
2. Increase the separation between the equipment and receiver.
3. Connect the equipment into an outlet on a circuit different from that to which the receiver is connected.
4. Consult the dealer or an experienced radio / TV technician for help.

General Information

Water ingress

Water ingress disclaimer

Although the waterproof rating capacity of this product meets the stated IPX standard (refer to the product's *Technical Specification*), water intrusion and subsequent equipment failure may occur if the product is subjected to commercial high-pressure washing. Raymarine will not warrant products subjected to high-pressure washing.

Disclaimer

Raymarine does not warrant that this product is error-free or that it is compatible with products manufactured by any person or entity other than Raymarine.

Raymarine is not responsible for damages or injuries caused by your use or inability to use the product, by the interaction of the product with products manufactured by others, or by errors in information utilized by the product supplied by third parties.

FCC

Compliance Statement (Part 15.19)

This device complies with Part 15 of the FCC Rules. Operation is subject to the following two conditions:

1. This device may not cause harmful interference.
2. This device must accept any interference received, including interference that may cause undesired operation.

FCC Interference Statement (Part 15.105 (b))

This equipment has been tested and found to comply with the limits for a Class B digital device, pursuant to Part 15 of the FCC Rules.

These limits are designed to provide reasonable protection against harmful interference in a residential installation. This equipment generates, uses, and can radiate radio frequency energy and, if not installed and used in accordance with the instructions, may cause harmful interference to radio communications. However, there is no guarantee that interference will not occur in a particular installation. If this equipment does cause harmful interference to radio or television reception, which

Industry Canada

This device complies with Industry Canada License-exempt RSS standard(s).

Operation is subject to the following two conditions:

1. This device may not cause interference; and
2. This device must accept any interference, including interference that may cause undesired operation of the device.

This Class B digital apparatus complies with Canadian ICES-003.

Licensing

Prior to using this product please check your national requirements for both operators and equipment licensing.

Station Licence

FCC station license requirement

An FCC Ship Radio Station License and Call Sign are not required for most recreational vessels travelling in US waters. However, you must obtain a license if your vessel travels to foreign ports.

Ships that use MF/HF single side-band radio, satellite communications, or telegraphy must be licensed by the FCC. You can obtain a Station License by filing FCC Form 605, which is available from the FCC website listed above.

Industry Canada

Industry Canada license requirement

You do not need a license to operate this product within sovereign waters of Canada or the US. You will need a license to operate this radio outside of Canada or the US. To obtain Industry Canada licensing information, contact the nearest field or regional office, or write:

Industry Canada Radio Regulatory Branch
Attention: DOSP
300 Slater Street
Ottawa, Ontario
Canada, KIA OC8

European licensing requirements

Regulations in some areas require that an Operator's license is obtained before operating a VHF radio. It is your responsibility to determine whether a license is required in your area before operating this equipment.

Additional information – Ray50

The following additional information is required for completing a license application in Canada and the US.

Industry Canada certification number	4069B-RAY50D
FCC ID	PJ5-RAY50
FCC Type accepted	Parts 2, 15 and 80
Output power	1 watt (low) and 25 watt (high)
Modulation	FM
Frequency range	155.500 MHz to 163.275 MHz

Additional information – Ray60

The following additional information is required for completing a license application in Canada and the US.

Industry Canada certification number	4069B-RAY60D
FCC ID	PJ5-RAY60
FCC Type accepted	Parts 2, 15 and 80
Output power	1 watt (low) and 25 watt (high)
Modulation	FM
Frequency range	155.500 MHz to 163.275 MHz

Additional information – Ray70

The following additional information is required for completing a license application in Canada and the US.

Industry Canada certification number	4069B-RAY70D
FCC ID	PJ5-RAY70
FCC Type accepted	Parts 2, 15 and 80
Output power	1 watt (low) and 25 watt (high)
Modulation	FM
Frequency range	155.500 MHz to 163.275 MHz

Maritime Mobile Service Identity (MMSI)

This product is a class "D" Digital Selective Calling (DSC) device.

A 9 digit MMSI number is required to operate DSC equipment. In some areas, a radio operator license is required before an MMSI number can be issued.

Note: You can request an MMSI number from the same agency that issues radio or ship radio licenses in your area. Once obtained, you can program the MMSI number into your product by following the instruction supplied with the product.

Once obtained, you can program the MMSI number into your product using the instructions provided.

If regulations in your area do not permit you to program the MMSI number yourself, your Raymarine dealer can program the number for you.

Obtaining an MMSI number in the United States

You can request an MMSI number from the FCC when you apply for a Station License. If your vessel does not require a license, you may obtain an MMSI by contacting BoatUS www.boatus.com.

Obtaining an MMSI number in Canada

You can obtain an MMSI number from your nearest Industry Canada Office.

Obtaining an MMSI number in Europe and rest of world

An MMSI number should be requested from the same agency that issues radio operator licenses in your area.

Automatic Transmitter Identification System (ATIS)

Your product includes ATIS functionality for use on the inland waterways of contracting governments of the "Regional Arrangement on the Radiocommunication Service for Inland Waterways" — also known as "RAINWAT".

ATIS adds data at the end of radio transmissions that identifies your station. ATIS operation can be turned on or off as needed via the radio's menu.

An ATIS ID can be obtained from the same agency that issues radio operator licenses in your area.

Your ATIS ID should be programmed into your product using the instructions provided.

Note: Contracting RAINWAT countries include: Austria, Belgium, Bulgaria, Croatia, the Czech Republic, France, Germany, Hungary, Luxembourg, Moldova, Montenegro, the Netherlands, Poland, Romania, Serbia, the Slovak Republic and Switzerland.

Note: When ATIS is enabled, certain programming steps have been implemented to protect the integrity of the RAINWAT agreement, including the blocking of DSC functions when ATIS is enabled.

EMC installation guidelines

Raymarine equipment and accessories conform to the appropriate Electromagnetic Compatibility (EMC) regulations, to minimize electromagnetic interference between equipment and minimize the effect such interference could have on the performance of your system

Correct installation is required to ensure that EMC performance is not compromised.

Note: In areas of extreme EMC interference, some slight interference may be noticed on the product. Where this occurs the product and the source of the interference should be separated by a greater distance.

For **optimum** EMC performance we recommend that wherever possible:

- Raymarine equipment and cables connected to it are:
 - At least 1 m (3 ft) from any equipment transmitting or cables carrying radio signals e.g. VHF radios, cables and antennas. In the case of SSB radios, the distance should be increased to 7 ft (2 m).
 - More than 2 m (7 ft) from the path of a radar beam. A radar beam can normally be assumed to spread 20 degrees above and below the radiating element.
- The product is supplied from a separate battery from that used for engine start. This is important to prevent erratic behavior and data loss which can occur if the engine start does not have a separate battery.
- Raymarine specified cables are used.
- Cables are not cut or extended, unless doing so is detailed in the installation manual.

Note: Where constraints on the installation prevent any of the above recommendations, always ensure the maximum possible separation between different items of electrical equipment, to provide the best conditions for EMC performance throughout the installation

Antenna mounting and EME exposure

Ensure that the antenna is connected to the radio before transmission.

Raymarine declares a Maximum Permissible Exposure (MPE) radius of 1.5 metres (4.9 ft) (per OET Bulletin 65) for this system, assuming 25 watts output to an omnidirectional antenna of 3dBi gain or less.

For watercraft with suitable structures, the antenna base must be at least 3.5 metres (11.5 ft) above the main deck to meet the MPE for persons up to 2 metres (6.6 ft) tall. For watercraft without such structures, the antenna must be mounted so that its base is a minimum of 1.5 metres (4.9 ft) vertically from heads of all persons.

The antenna must be isolated from the vessel's metalwork using an insulated (e.g. plastic) mounting bracket.

Connections to other equipment

Requirement for ferrites on non-Raymarine cables

If your Raymarine equipment is to be connected to other equipment using a cable not supplied by Raymarine, a suppression ferrite **MUST** always be attached to the cable near the Raymarine unit.

Declaration of conformity

Raymarine UK Ltd. declares that this product is compliant with the essential requirements of R&TTE directive 1999/5/EC.

The original Declaration of Conformity certificate may be viewed on the relevant product page at www.raymarine.com.

Product disposal

Dispose of this product in accordance with the WEEE Directive.



The Waste Electrical and Electronic Equipment (WEEE) Directive requires the recycling of waste electrical and electronic equipment. Whilst the WEEE Directive does not apply to some Raymarine products, we support its policy and ask you to be aware of how to dispose of this product.

Warranty registration

To register your Raymarine product ownership, please visit www.raymarine.com and register online.

It is important that you register your product to receive full warranty benefits. Your unit package includes a bar code label indicating the serial number of the unit. You will need this serial number when registering your product online. You should retain the label for future reference.

IMO and SOLAS

The equipment described within this document is intended for use on leisure marine boats and workboats NOT covered by International Maritime Organization (IMO) and Safety of Life at Sea (SOLAS) Carriage Regulations.

Technical accuracy

To the best of our knowledge, the information in this document was correct at the time it was produced. However, Raymarine cannot accept liability for any inaccuracies or omissions it may contain. In addition, our policy of continuous product improvement may change specifications without notice. As a result, Raymarine cannot accept liability for any differences between the product and this document. Please check the Raymarine website (www.raymarine.com) to ensure you have the most up-to-date version(s) of the documentation for your product.

Chapter 2: Document and product information

Chapter contents

- [2.1 Document information on page 12](#)
- [2.2 Product information on page 13](#)

SWIB

2.1 Document information

This document contains important information related to the installation of your Raymarine product.



The document includes information to help you:

- plan your installation and ensure you have all the necessary equipment;
- install and connect your product as part of a wider system of connected marine electronics;
- troubleshoot problems and obtain technical support if required.

This and other Raymarine product documents are available to download in PDF format from www.raymarine.com.

Applicable products

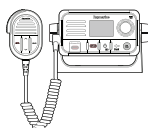
This document is applicable to the following products:

	Name	Part number	Features
	E70243	Ray50	<ul style="list-style-type: none"> • SeaTalk^{ng}® / NMEA 2000 • NMEA 0183 • Passive speaker connection
	E70245	Ray60	<ul style="list-style-type: none"> • SeaTalk^{ng}® / NMEA 2000 • NMEA 0183 • Passive speaker connection • Up to 2 stations
	E70251	Ray70	Same as Ray60 with additional: <ul style="list-style-type: none"> • Built-in AIS receiver • Built-in GNSS (GPS and GLONASS) receiver • Loud hailer connection

Document conventions

The following conventions are used throughout this document when referring to:

Type	Example	Convention
Procedures for performing specific tasks using the product's user interface.	Select Set-Up .	The term "Select" is used to refer to the action of: <ul style="list-style-type: none"> • Touchscreen control — using your finger to select a menu option or item on the screen. • Physical buttons — Highlighting an item using the navigational buttons and confirming the selection by pressing the OK button.
Procedures for navigating menu hierarchies.	1. The internal sonar module is turned off from the Fishfinder application menu: Menu > Set-up > Sounder Set-up > Internal Sounder . 2. The internal GPS can be switched off from the Set-up menu: Menu > Set-up > GPS Set-up > Internal GPS .	Menu hierarchies are used in this document to provide a quick summary on how to access a particular function or menu option.

Document illustrations

Your product may differ slightly from that shown in the illustrations in this document, depending on product variant and date of manufacture.

All images are provided for illustration purposes only.

Product documentation

The following documentation is applicable to your product:

Description	Part number
Installation and operation instructions	81356
Ray50 mounting template	87218
Ray60 / Ray70 mounting template	87219

All documents are available to download in pdf format from the Raymarine website www.raymarine.com.

SeaTalk^{ng} handbooks

Description	Part number
SeaTalk^{ng} reference manual Planning and connection of systems based around the SeaTalk ^{ng} network.	81300
SeaTalk – SeaTalk^{ng} converter handbook Installation and connection of the SeaTalk - SeaTalk ^{ng} converter.	87121

User manuals Print Shop

Raymarine provides a Print Shop service, enabling you to purchase a high-quality, professionally-printed manual for your Raymarine product.

Printed manuals are ideal for keeping onboard your vessel, as a useful source of reference whenever you need assistance with your Raymarine product.

Visit <http://www.raymarine.co.uk/view/?id=5175> to order a printed manual, delivered directly to your door.

For further information about the Print Shop, please visit the Print Shop FAQ pages: <http://www.raymarine.co.uk/view/?id=5751>.

Note:

- Accepted methods of payment for printed manuals are credit cards and PayPal.
- Printed manuals can be shipped worldwide.
- Further manuals will be added to the Print Shop over the coming months for both new and legacy products.
- Raymarine user manuals are also available to download free-of-charge from the Raymarine website, in the popular PDF format. These PDF files can be viewed on a PC / laptop, tablet, smartphone, or on the latest generation of Raymarine multifunction displays.

2.2 Product information

The **Ray50**, **Ray60** and **Ray70** are 12 V dc, Class D Digital Selective Calling (DSC) VHF radios. DSC enables you to make a selective call to a specific radio, and to transmit and receive position information to and from the selected radio. DSC also allows transmission of a distress alert to all radios within range at the touch of a button. Once a DSC request is sent and acknowledged voice communication is carried out on the channel chosen by the caller. The radio can transmit and receive on all available US, Canadian, International and Private marine VHF channels.

Your product includes a base station and a fixed or detachable Fistmic, depending on variant. A Raymic handset accessory is available for the **Ray60** and **Ray70** which can be connected as a second fully functional station.

With an optional loud hailer connected the **Ray70** can also be used as a fog horn or loud public address (PA) system.

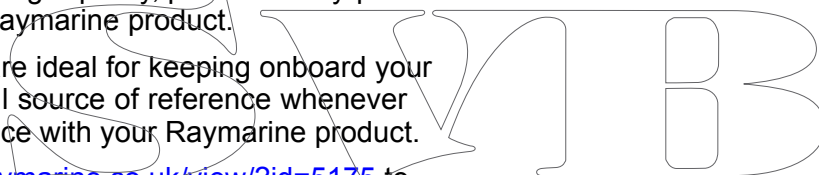

SWIB

Chapter 3: Planning the installation

Chapter contents

- 3.1 Installation checklist on page 16
- 3.2 Parts supplied – **Ray50** on page 16
- 3.3 Parts supplied – **Ray60 / Ray70** on page 17
- 3.4 Software updates on page 17
- 3.5 Tools required for installation on page 18
- 3.6 System integration — **Ray50** on page 19
- 3.7 System integration — **Ray60 / Ray70** on page 20
- 3.8 System protocols on page 21
- 3.9 General location requirements on page 22
- 3.10 Mounting options on page 23
- 3.11 Product dimensions on page 24

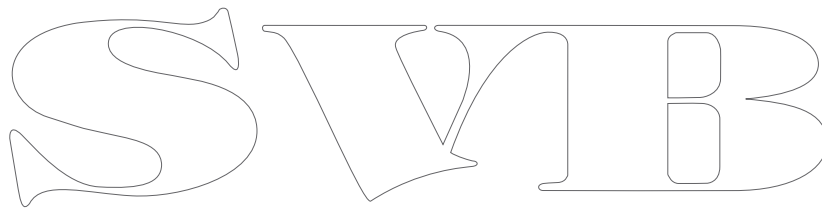

3.1 Installation checklist

Installation includes the following activities:

Installation Task	
1	Plan your system.
2	Obtain all required equipment and tools.
3	Site all equipment.
4	Route all cables.
5	Drill cable and mounting holes.
6	Make all connections into equipment.
7	Secure all equipment in place.
8	Power on and test the system.

Schematic diagram

A schematic diagram is an essential part of planning any installation. It is also useful for any future additions or maintenance of the system. The diagram should include:

- Location of all components.
- Connectors, cable types, routes and lengths.

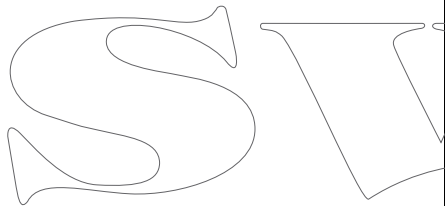

3.2 Parts supplied – Ray50

The parts listed below are supplied with the **Ray50**

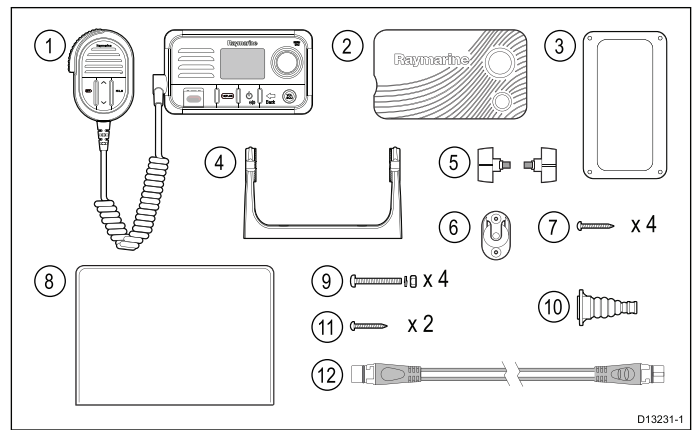

Item	Description
1	Ray50 with Fistmic
2	Sun cover
3	Panel mount gasket
4	Mounting bracket
5	Mounting bracket knobs
6	Fistmic mounting clip
7	4 x Mounting bracket fixings
8	Documentation
9	4 x Panel mount fixings comprising: (nut, bolt and locking washer)
10	Protective antenna boot
11	2 x Fistmic mounting clip fixings
12	SeaTalkng ® 400 mm (15.7 in.) spur cable

3.3 Parts supplied – Ray60 / Ray70

The parts listed below are supplied with the **Ray60** and **Ray70**.

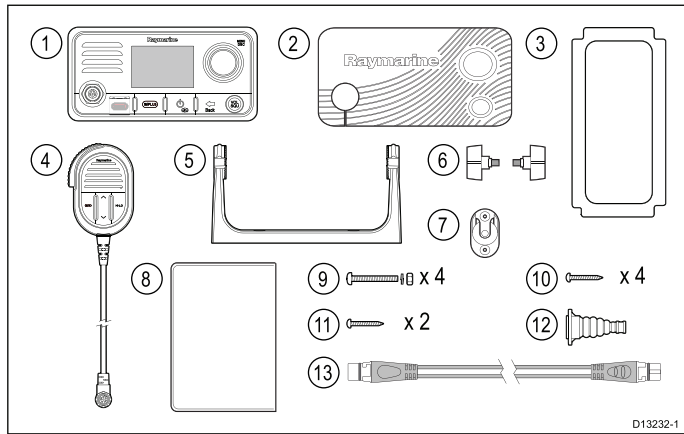

Item	Description
1	Ray60 / Ray70 base station
2	Sun cover
3	Flush mount gasket
4	Fistmic
5	Mounting bracket
6	Mounting bracket knobs
7	Fistmic mounting clip
8	Documentation
9	4 x Flush mount fixings comprising: (nut, bolt and locking washer)
10	4 x Mounting bracket fixings
11	2 x Fistmic mounting clip fixings
12	Protective antenna boot
13	SeaTalkng ® 400 mm (15.7 in.) spur cable

3.4 Software updates

The software running on the product can be updated.

- Raymarine periodically releases software updates to improve product performance and add new features.
- You can update the software for your product using a connected and compatible multifunction display.
- Refer to www.raymarine.com/software/ for the latest software updates and the software update procedure for your product.
- If in doubt as to the correct procedure for updating your product software, refer to your dealer or Raymarine technical support.

Caution: Downloading software updates

The software update process is carried out at your own risk. Before initiating the update process ensure you have backed up any important files.

Ensure that the unit has a reliable power supply and that the update process is not interrupted.

Damage caused by incomplete updates are not covered by Raymarine warranty.

By downloading the software update package, you agree to these terms.

3.5 Tools required for installation

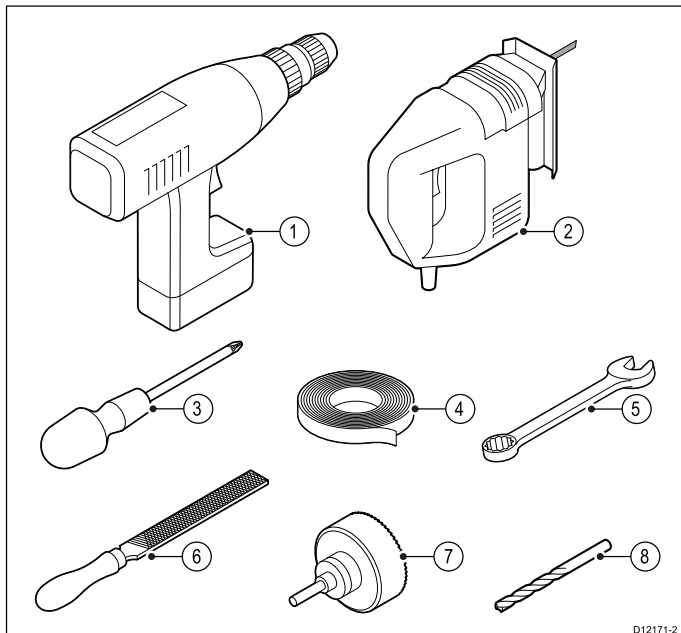

1. Power drill
2. Jigsaw for panel mount cut-out
3. Pozi-drive screwdriver
4. Adhesive tape
5. 7 mm (9/32") Wrench (spanner) for bracket mounting fixings
6. File for panel mount cut out
7. Hole saw for panel mounting (For hole saw size refer to your product's mounting template)
8. Drill bit for surface mounting or bracket mounting

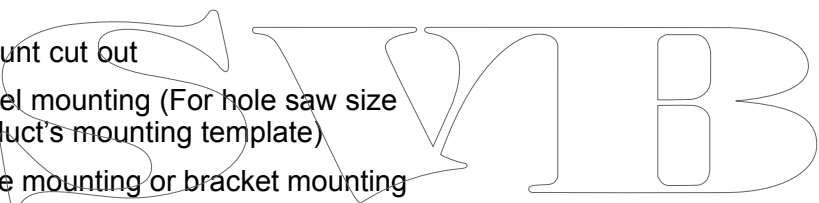

3.6 System integration — Ray50

Your VHF radio can be connected to the following marine electronics devices.

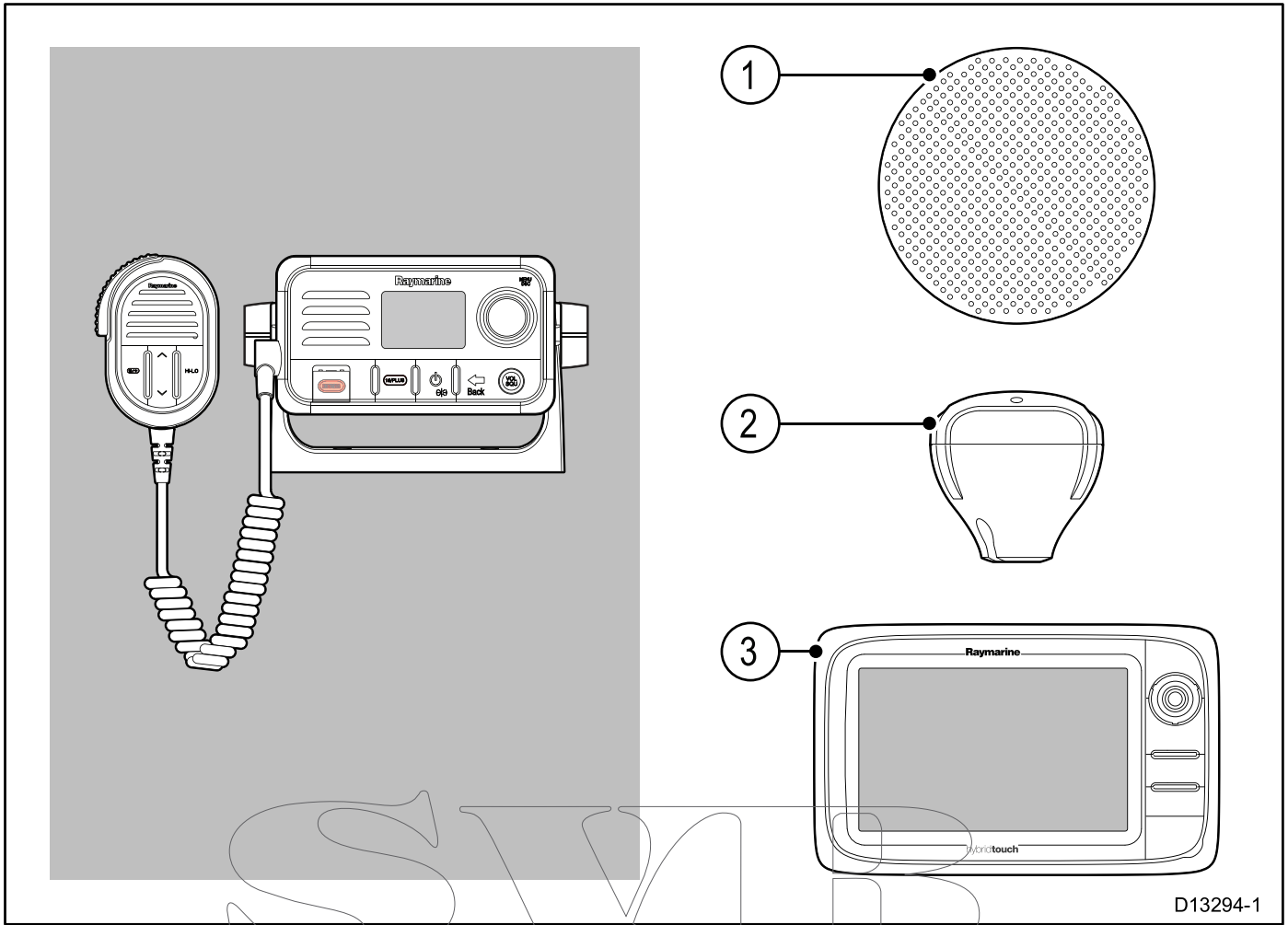

D13294-1

Item	Device type	Maximum quantity	Suitable devices	Connections
1	Passive speaker	1	3rd party 5 W (4 Ω) / 2.5 W (8 Ω) passive speaker	RCA audio connector
2	GPS Receiver	1 active	<ul style="list-style-type: none"> • RS130 • RS125 • Raymarine multifunction display equipped with internal GPS 	SeaTalk ^{ng} ® / NMEA 2000 or NMEA 0183
3	Raymarine multifunction display	10 LightHouse II displays	<ul style="list-style-type: none"> • a Series • c Series • e Series • gS Series • C-Series Widescreen • E-Series Widescreen • G-Series system 	SeaTalk ^{ng} ® / NMEA 2000 or NMEA 0183

3.7 System integration — Ray60 / Ray70

Your VHF radio can be connected to the following marine electronics devices.

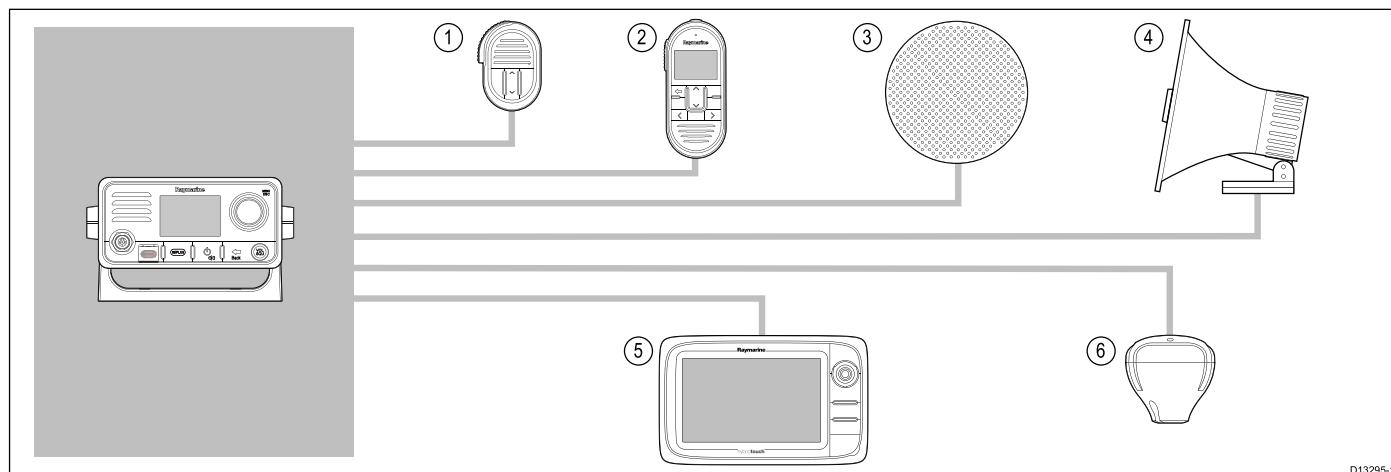

D13295-1

Item	Device type	Maximum quantity	Suitable devices	Connections
1	Fistmic	1	Fistmic	Front connector or rear connector via adaptor cable.
2	Handset	1	Ray60 / Ray70 Raymic Handset	Rear connector
3	Passive speaker	1 per station	3rd party 5 W (4 Ω) / 2.5 W (8 Ω) passive speaker	RCA audio connection
4	Loud hailer	1 – Ray70 only.	<ul style="list-style-type: none"> • 25 W 4 Ω / 12 W 8 Ω Loud hailer • 25 W 4 Ω / 12 W 8 Ω Loud hailer with listen-back 	Hailer wires
5	Raymarine multifunction display	10 LightHouse™ II displays	<ul style="list-style-type: none"> • a Series • c Series • e Series • gS Series • C-Series Widescreen • E-Series Widescreen • G-Series system 	SeaTalk^{ng}® / NMEA 2000 or NMEA 0183
6	GPS Receiver	1 active	<ul style="list-style-type: none"> • RS130 • RS125 • Raymarine multifunction display equipped with internal GPS 	SeaTalk^{ng}® / NMEA 2000

3.8 System protocols

Your product can send and receive position information, e.g. latitude and longitude using any of the following protocols:

- SeaTalk^{ng}
- NMEA 2000
- NMEA 0183

Using these protocols enables your radio to send position information to other devices in your system whenever it receives:

- a response to a DSC position request.
- a DSC distress call

Note: You may find that your product or system does not use all of the protocols described in this section.

Seataalk^{ng}

SeaTalk^{ng} (Next Generation) is an enhanced protocol for connection of compatible marine instruments and equipment. It replaces the older SeaTalk and SeaTalk² protocols.

SeaTalk^{ng} utilizes a single backbone to which compatible instruments connect using a spur. Data and power are carried within the backbone. Devices that have a low draw can be powered from the network, although high current equipment will need to have a separate power connection.

SeaTalk^{ng} is a proprietary extension to NMEA 2000 and the proven CAN bus technology. Compatible NMEA 2000 and SeaTalk / SeaTalk² devices can also be connected using the appropriate interfaces or adaptor cables as required.

NMEA 2000

NMEA 2000 offers significant improvements over NMEA 0183, most notably in speed and connectivity. Up to 50 units can simultaneously transmit and receive on a single physical bus at any one time, with each node being physically addressable. The standard was specifically intended to allow for a whole network of marine electronics from any manufacturer to communicate on a common bus via standardized message types and formats.

NMEA 0183

The NMEA 0183 Data Interface Standard was developed by the National Marine Electronics Association of America. It is an international standard to enable equipment from many different manufacturers to be connected together and share information.

The NMEA 0183 standard carries similar information to SeaTalk. However it has the important difference that one cable will only carry information in one direction. For this reason NMEA 0183 is generally used to connect a data receiver and a transmitter together, e.g. a compass sensor transmitting heading to a radar display. This information is

passed in 'sentences', each of which has a three letter sentence identifier. It is therefore important when checking compatibility between items that the same sentence identifiers are used some examples of which are:

- VTG - carries Course and Speed Over Ground data.
- GLL - carries latitude and longitude.
- DBT - carries water depth.
- MWV - carries relative wind angle and wind speed data.

NMEA Baud rates

The NMEA 0183 standard operates at a number of different speeds, depending upon the particular requirement or equipment capabilities. Typical examples are:

- 4800 baud rate. Used for general purpose communications, including FastHeading data.
- 38400 baud rate. Used for AIS and other high speed applications.

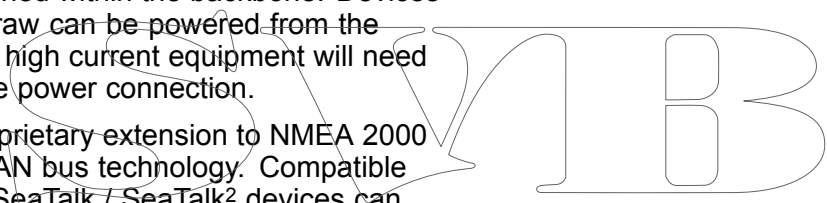

3.9 General location requirements

When selecting a location for the unit it is important to consider a number of factors.

Antenna mounting and EME exposure

Ensure that the antenna is connected to the radio before transmission.

Raymarine declares a Maximum Permissible Exposure (MPE) radius of 1.5 metres (4.9 ft) (per OET Bulletin 65) for this system, assuming 25 watts output to an omnidirectional antenna of 3dBi gain or less.

For watercraft with suitable structures, the antenna base must be at least 3.5 metres (11.5 ft) above the main deck to meet the MPE for persons up to 2 metres (6.6 ft) tall. For watercraft without such structures, the antenna must be mounted so that its base is a minimum of 1.5 metres (4.9 ft) vertically from heads of all persons.

The antenna must be isolated from the vessel's metalwork using an insulated (e.g. plastic) mounting bracket.

Compass safe distance

To prevent potential interference with the vessel's magnetic compasses, ensure an adequate distance is maintained from the product.

When choosing a suitable location for the product you should aim to maintain the maximum possible distance from any compasses. Typically this distance should be at least 1 m (3 ft) in all directions. However for some smaller vessels it may not be possible to locate the product this far away from a compass. In this situation, when choosing the installation location for your product, ensure that the compass is not affected by the product when it is in a powered state.



GPS location requirements

In addition to general guidelines concerning the location of marine electronics, there are a number of environmental factors to consider when installing equipment with an internal GPS antenna.

Mounting location

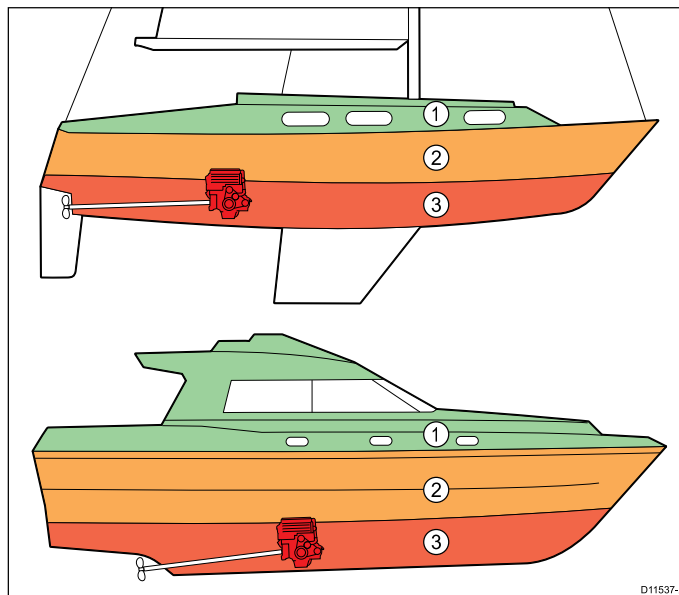
- **Above Decks mounting:**
Provides optimal GPS performance. (For equipment with appropriate waterproof rating.)
- **Below Decks mounting:**
GPS performance may be less effective and may require an external GPS antenna mounted above decks.



1.		This location provides optimal GPS performance (above decks).
2.		In this location, GPS performance may be less effective.
3.		This location is NOT recommended for GPS antenna.

Vessel construction

The construction of your vessel can have an impact on GPS performance. For example, the proximity of heavy structure such as a structural bulkhead, or the interior of larger vessels may result in a reduced GPS signal. Before locating equipment with an internal GPS antenna below decks, seek professional assistance and consider use of an external GPS antenna mounted above decks.

Prevailing conditions

The weather and location of the vessel can affect the GPS performance. Typically calm clear conditions provide for a more accurate GPS fix. Vessels at extreme northerly or southerly latitudes may also receive a weaker GPS signal. GPS antenna mounted below decks will be more susceptible to performance issues related to the prevailing conditions.

Ventilation requirements

To provide adequate airflow:

- Ensure that equipment is mounted in a compartment of suitable size.
- Ensure that ventilation holes are not obstructed.
- Ensure adequate separation of equipment.

Mounting surface requirements

Ensure units are adequately supported on a secure surface. Do NOT mount units or cut holes in places which may damage the structure of the vessel.

Cable routing requirements

Ensure the unit is mounted in a location which allows proper routing and connection of cables:

- Minimum cable bend radius of 100 mm (3.94 in) is required unless otherwise stated.

- Use cable supports to prevent stress on connectors.

Electrical interference

Select a location that is far enough away from devices that may cause interference, such as motors, generators and radio transmitters/receivers.

Power supply

Select a location that is as close as possible to the vessel's DC power supply. This will help to keep cable runs to a minimum.

3.10 Mounting options

The product can be mounted in the following configurations.

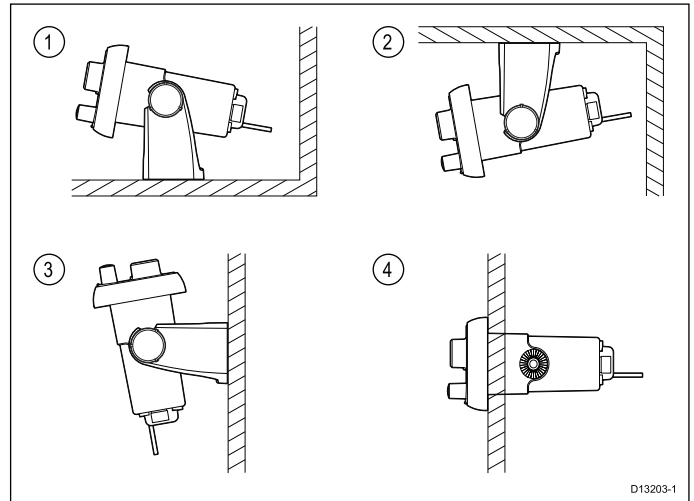

1. Table top mount
2. Overhead mount
3. Bulkhead mount
4. Panel mount

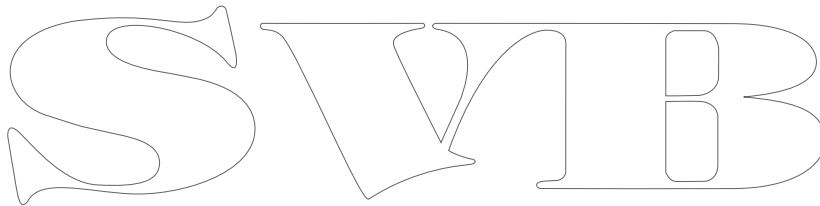

3.11 Product dimensions

Ray50 product dimensions

The **Ray50** can be panel mounted or bracket mounted.

Ray50 dimensions (panel mount)

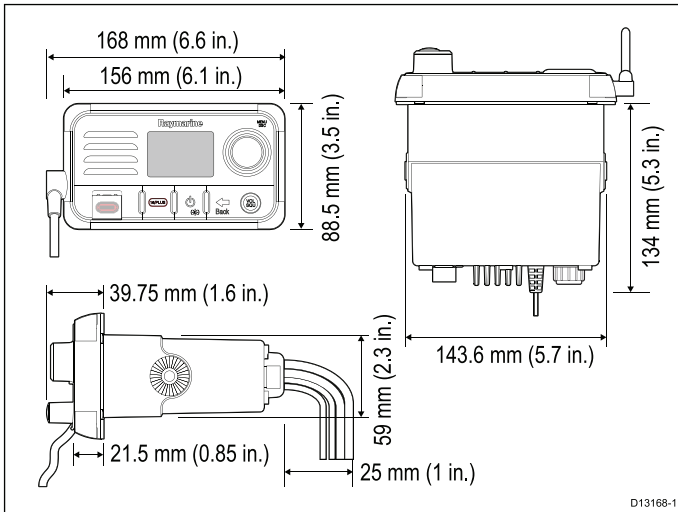

Ray50 dimensions (bracket mount)

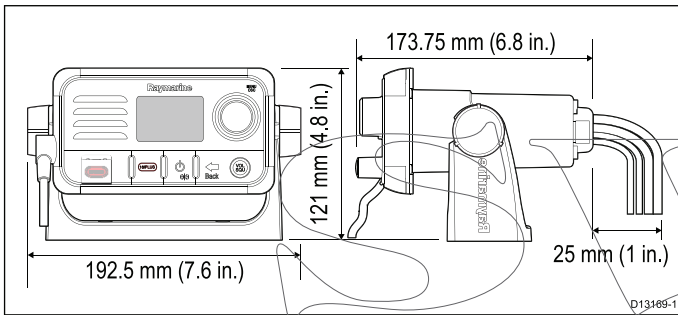

Ray60 and Ray70 product dimensions

The **Ray60** and **Ray70** can be panel or bracket mounted.

Ray60 and Ray70 dimensions (panel mount)

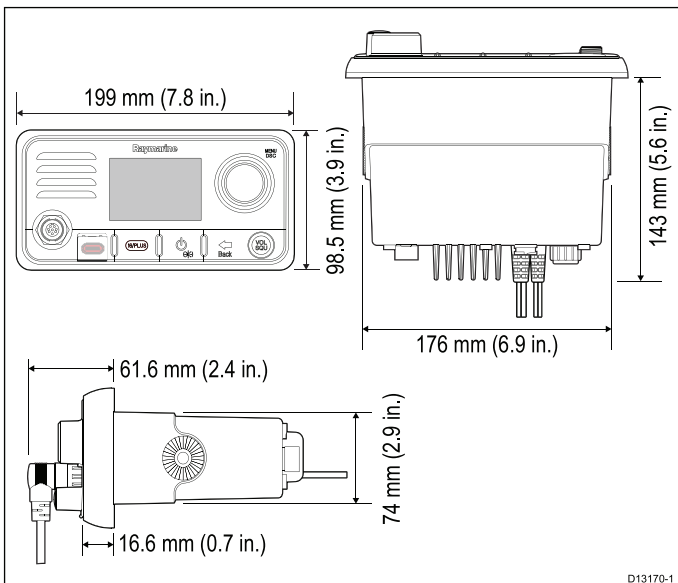

Ray60 and Ray70 dimensions (bracket mount)

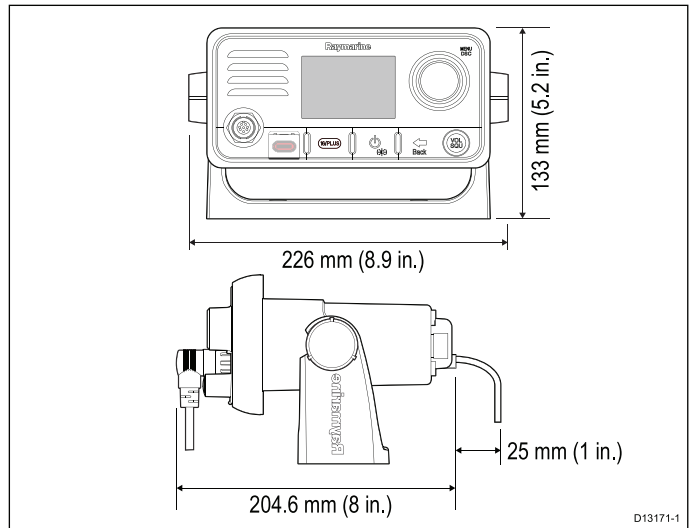

Fistmic dimensions

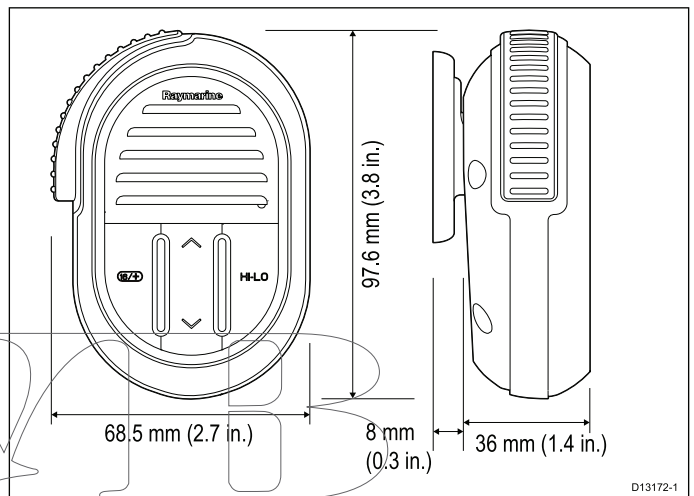

The Fistmic's fitted, coiled lead can be extended comfortably to approximately 1 meter (3.3 ft.)

Raymic handset accessory dimensions

The Raymic handset is available as an accessory for the **Ray60** and **Ray70**.

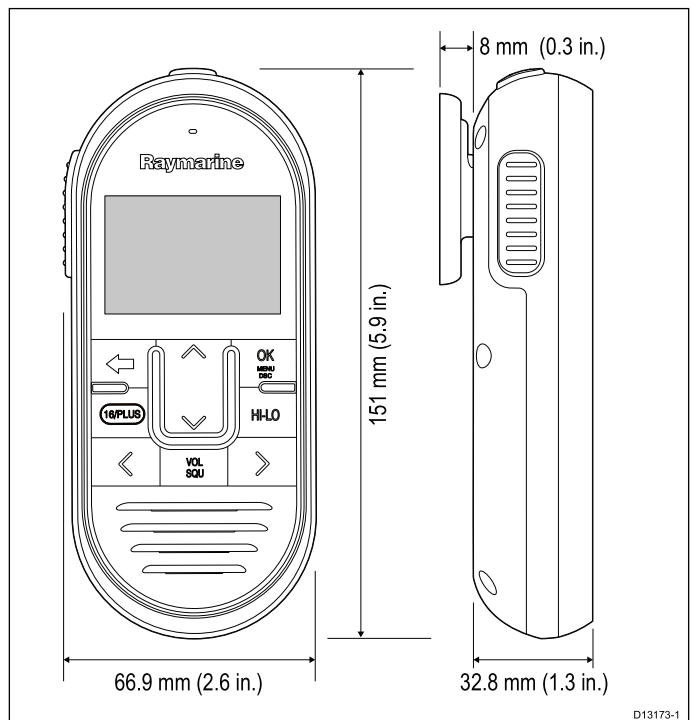

The Handset's fitted, coiled lead can be extended comfortably to approximately 1 meter (3.3 ft.)

SWIB

SWIB

Chapter 4: Cables and connections

Chapter contents

- 4.1 General cabling guidance on page 28
- 4.2 Connections overview - Ray50 on page 29
- 4.3 Connections overview **Ray60 / Ray70** on page 29
- 4.4 Power connection on page 30
- 4.5 Connecting handsets and cables on page 31
- 4.6 Fistmic connection **Ray60 / Ray70** on page 32
- 4.7 **SeaTalk^{ng}**® connection on page 33
- 4.8 **NMEA 0183** connection on page 34
- 4.9 Connecting an antenna on page 34
- 4.10 Second handset station — **Ray60 / Ray70** on page 35
- 4.11 Passive speaker connection on page 35
- 4.12 Loud hailer connection on page 36

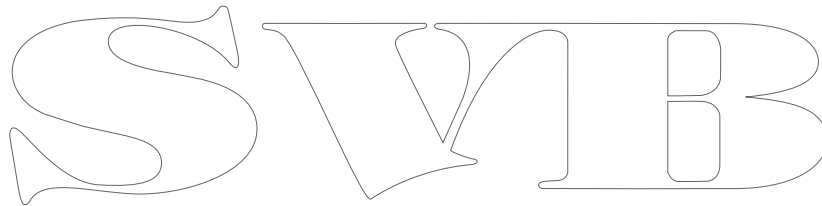

4.1 General cabling guidance

Cable types and length

It is important to use cables of the appropriate type and length

- Unless otherwise stated use only standard cables of the correct type, supplied by Raymarine.
- Ensure that any non-Raymarine cables are of the correct quality and gauge. For example, longer power cable runs may require larger wire gauges to minimize voltage drop along the run.

Routing cables

Cables must be routed correctly, to maximize performance and prolong cable life.

- Do NOT bend cables excessively. Wherever possible, ensure a minimum bend diameter of 200 mm (8 in) / minimum bend radius of 100 mm (4 in).

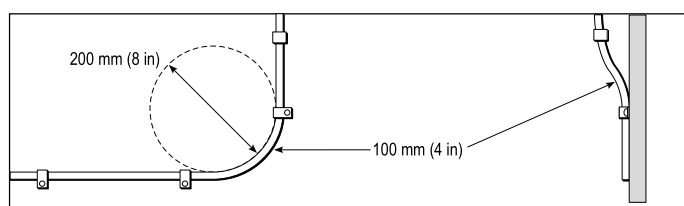

- Protect all cables from physical damage and exposure to heat. Use trunking or conduit where possible. Do NOT run cables through bilges or doorways, or close to moving or hot objects.
- Secure cables in place using tie-wraps or lacing twine. Coil any extra cable and tie it out of the way.
- Where a cable passes through an exposed bulkhead or deckhead, use a suitable watertight feed-through.
- Do NOT run cables near to engines or fluorescent lights.

Always route data cables as far away as possible from:

- other equipment and cables,
- high current carrying ac and dc power lines,
- antennae.

Strain relief

Ensure adequate strain relief is provided. Protect connectors from strain and ensure they will not pull out under extreme sea conditions.

Circuit isolation

Appropriate circuit isolation is required for installations using both AC and DC current:

- Always use isolating transformers or a separate power-inverter to run PC's, processors, displays and other sensitive electronic instruments or devices.
- Always use an isolating transformer with Weather FAX audio cables.
- Always use an isolated power supply when using a 3rd party audio amplifier.

- Always use an RS232/NMEA converter with optical isolation on the signal lines.
- Always make sure that PC's or other sensitive electronic devices have a dedicated power circuit.

Cable shielding

Ensure that all data cables are properly shielded that the cable shielding is intact (e.g. hasn't been scraped off by being squeezed through a tight area).

Blanking plugs

Connectors not in use should be protected using blanking plugs.

Connectors on the product or accompanying cables, that are not in use (not connected), should be covered using blanking plugs if supplied.

4.2 Connections overview - Ray50

The following connections are available on the **Ray50**.

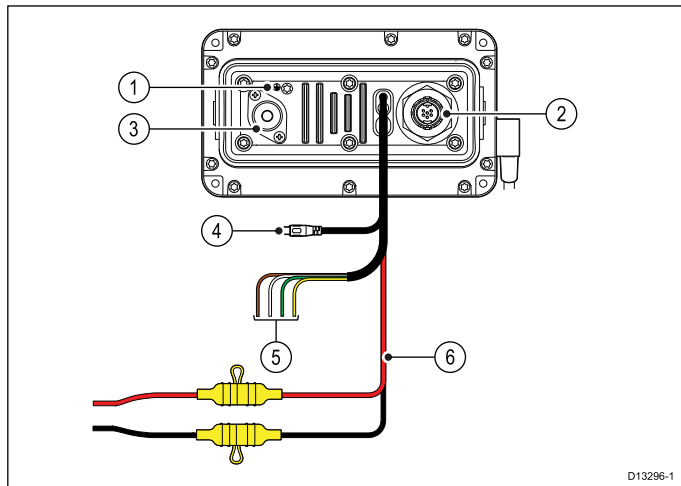

1. Ground point — DO NOT USE!
2. **SeaTalkng®**
3. Antenna
4. RCA Audio lead
5. **NMEA 0183**
6. Power supply connection

4.3 Connections overview Ray60 / Ray70

The following connections are available on the **Ray60** and **Ray70**.

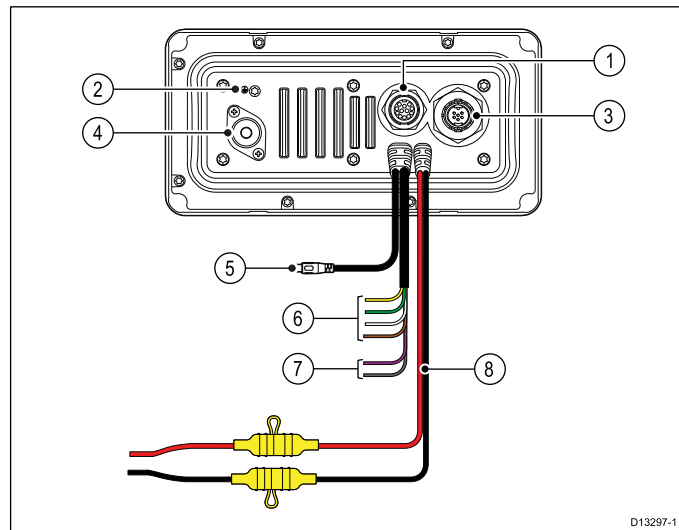

1. 2nd station connection
2. Ground point — DO NOT USE!
3. **SeaTalkng®**
4. Antenna
5. RCA Audio lead
6. **NMEA 0183**
7. Loud Hailer connection (**Ray70** only)
8. Power supply connection

SVTBB

4.4 Power connection

The power supply should be connected as shown below:

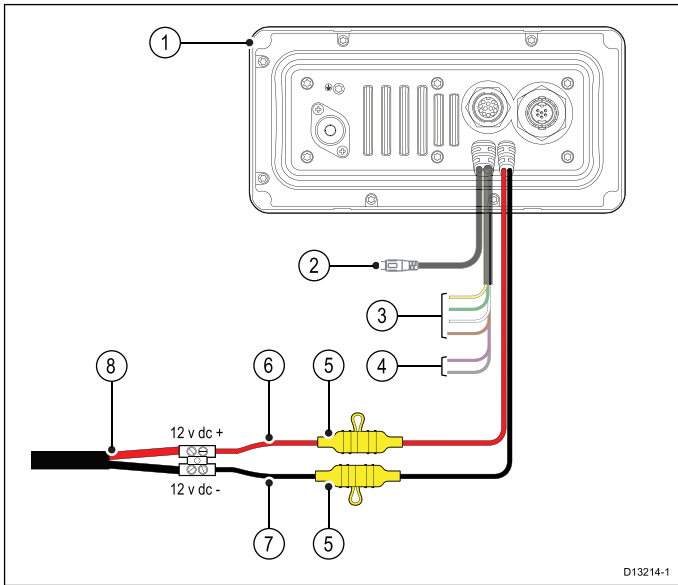

1. Base station
2. Passive speaker connection.
3. **NMEA 0183** wires
4. Loud hailer wires (**Ray70** only.)
5. In-line 10 A fuse
6. Red positive wire
7. Black negative wire.
8. Vessel's 12 V dc power supply



Warning: 12 Volt dc only

This product must only be connected to a 12 volt dc power source.



Warning: Chassis grounding

Do NOT ground this product using the chassis ground terminal.

Grounding this product to a vessel's RF ground may cause galvanic corrosion.

Grounding

This product is grounded through the 0 V dc negative wire on the power cable and does not require a drain (shield) to be connected to the base station's ground terminal.



Warning: Positive ground systems

Do not connect this unit to a system which has positive grounding.

Breakers, fuses and circuit protection

The information below is provided as guidance to help protect your product. The example illustrations provided are for common vessel power arrangements, if you are unsure how to provide the correct level of protection then please consult a Raymarine authorized dealer for support.

Distribution panel connection

It is recommended that your product is wired through your vessel's distribution panel via a thermal breaker or fuse.

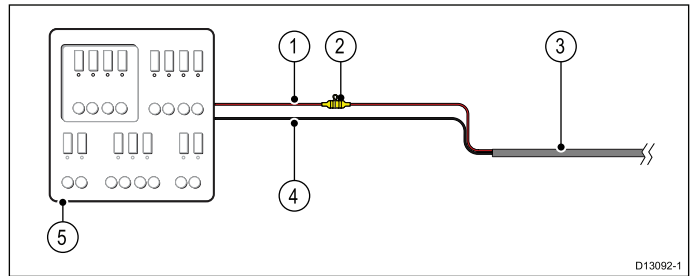

1. Vessel power supply positive (+)
2. In-line fuse. (If your product's power cable does not have an in-line fuse then one should be fitted.)
3. Product power cable
4. Vessel power supply negative (-)
5. Vessel distribution panel

Battery connection

Your product may be wired directly to the battery using an in-line fuse.

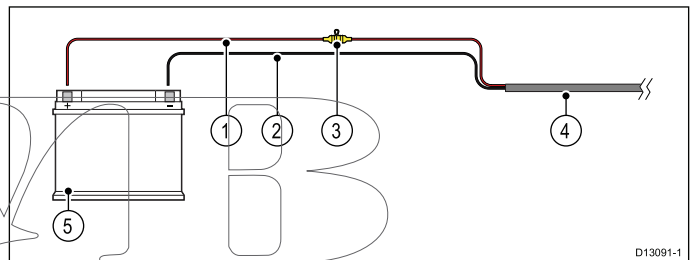

1. Vessel power supply positive (+)
2. Vessel power supply negative (-)
3. In-line fuse. (If your product's power cable does not have an in-line fuse then one should be fitted.)
4. Product power cable
5. Vessel battery

In-line fuse and thermal breaker ratings

The following in-line fuse and thermal breaker ratings apply to your product:

In-line fuse rating	Thermal breaker rating
10 A	7 A (if only connecting one device)

Note:

- The suitable fuse rating for the thermal breaker is dependent on the number of devices you are connecting. If in doubt consult an authorized **Raymarine**® dealer.
- Your product's power cable may have fitted in-line fuse, if not then you can add an in-line fuse to the positive wire of your products power connection.

Sharing a breaker

Where more than 1 piece of equipment shares a breaker you must provide protection for the individual circuits. E.g. by connecting an in-line fuse for each power circuit.

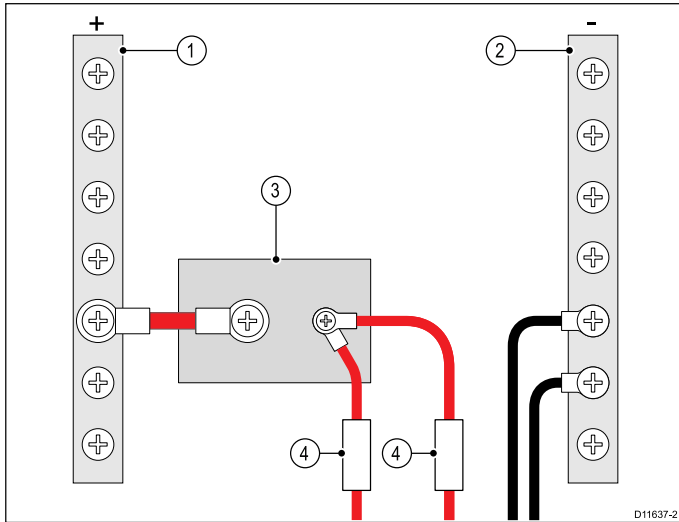

1	Positive (+) bar
2	Negative (-) bar
3	Circuit breaker
4	Fuse

Where possible, connect individual items of equipment to individual circuit breakers. Where this is not possible, use individual in-line fuses to provide the necessary protection.

4.5 Connecting handsets and cables

Follow the steps below to connect handsets and extension cables together.

1. Ensure the cable connectors are correctly orientated.
2. Ensure connectors are fully inserted.
3. Tighten locking collars by Rotating clockwise.

4.6 Fistmic connection Ray60 / Ray70

The Fistmic should primarily be connected to the front Fistmic connector. Using an adaptor cable the Fistmic can be connected to the rear second station connector, this is useful when the Fistmic is required to be slightly farther away from the base station than the Fistmic's cable allows.

The Fistmic must not be used as a second station as it will not be fully functional or have access to displayed important information.

Fistmic front connection

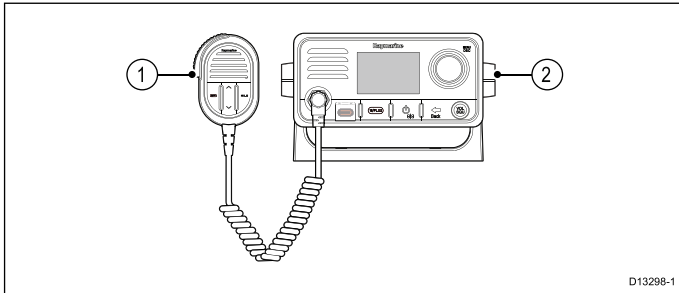

1. Fistmic
2. Base station

Fistmic rear connection

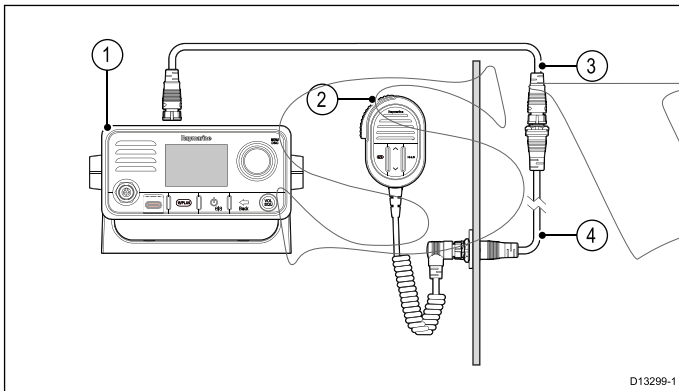

1. Base station
2. Fistmic
3. Raymic handset extension cable (A80291)
4. Fistmic adaptor cable (A80296)

Connecting the Fistmic – Ray60 / Ray70

The Fistmic can be connected directly to the connector on the front of the unit.

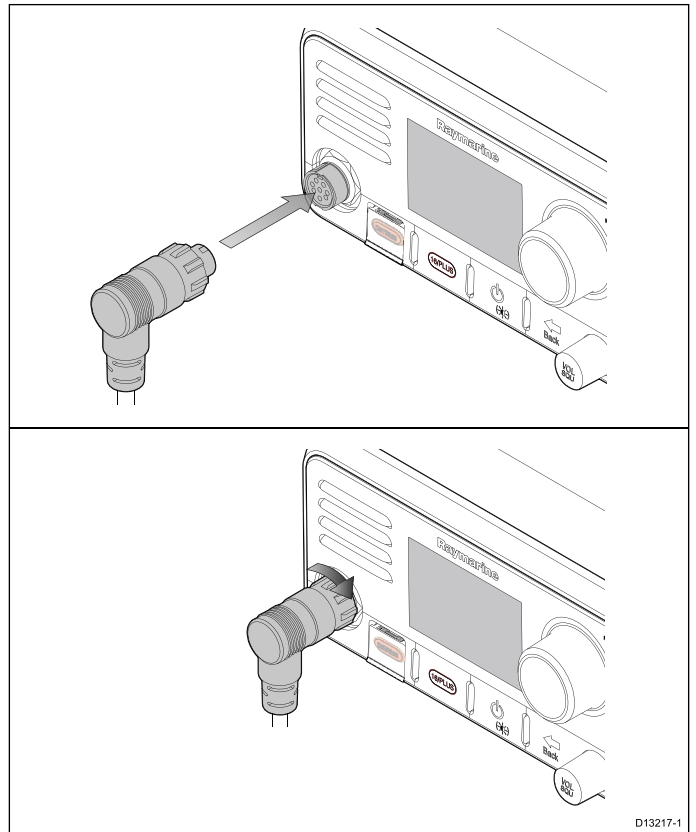

1. Ensure the Fistmic cable connector is correctly orientated.
2. Fully insert the connector into the connector on the front of the unit.
3. Rotate the locking collar clockwise until it clicks.

4.7 SeaTalk^{ng}® connection

The product can interface with **Raymarine**® GPS or GNSS receivers and **Raymarine**® multifunction displays using the **SeaTalk^{ng}**® connection.

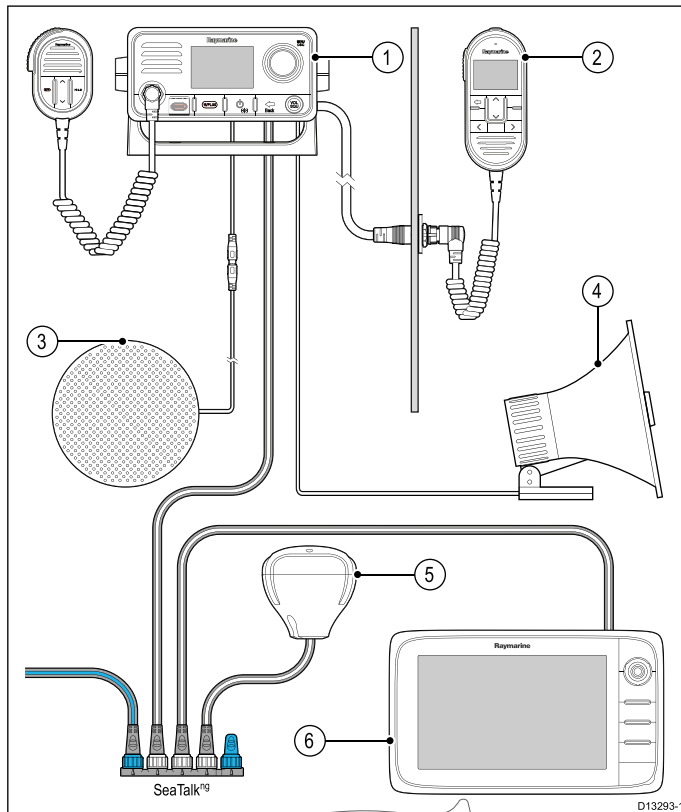

1. **Ray50 / Ray60 / Ray70**
2. Optional Raymic handset station (**Ray70** and **Ray70** only)
3. Optional 3rd party passive speaker
4. Loud hailer (**Ray70** only)
5. GPS Receiver
6. **Raymarine**® Multifunction display (**MFD**)

A **Raymarine**® **SeaTalk^{ng}**® GPS or GNSS receiver cannot be connected directly to the product, as GPS and GNSS receivers are powered via the **SeaTalk^{ng}**® backbone.

Connecting SeaTalk^{ng}®

Before connecting to **SeaTalk^{ng}**®, refer to the **SeaTalk^{ng}**® *Reference Manual*, to ensure that the maximum permitted Load Equivalence Number (LEN), for the **SeaTalk^{ng}**® backbone is not exceeded once this product is connected.

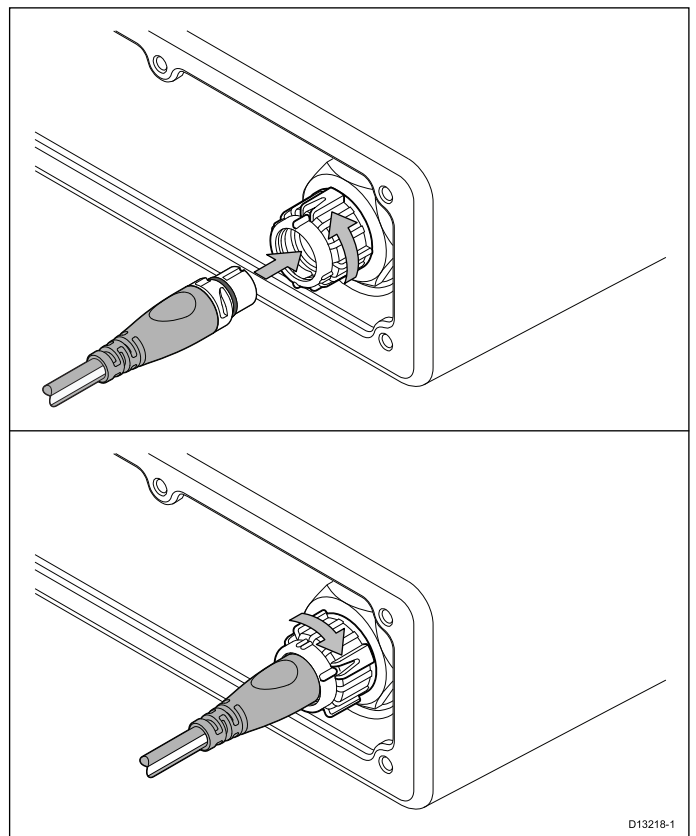

1. Rotate the **SeaTalk^{ng}**® connector's locking collar anti clockwise, to the unlocked position.
2. Ensure the spur cable connector is correctly orientated.
3. Fully insert the spur cable connector into the **SeaTalk^{ng}**® connector on the unit.
4. Rotate the locking collar clockwise 2 clicks, to the locked position.

4.8 NMEA 0183 connection

The **NMEA 0183** wires can be used to connect the unit to a 3rd party GPS/GNSS receiver or multifunction display.

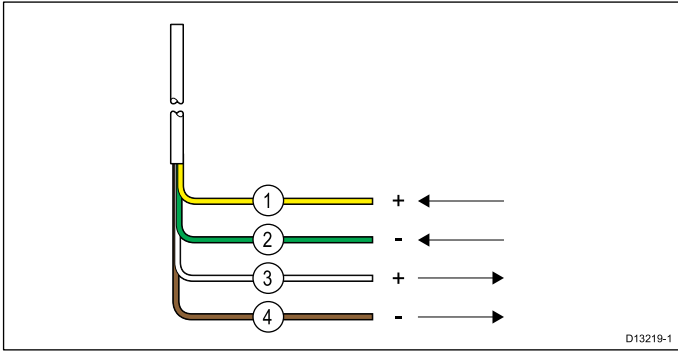

1. Yellow – Receive positive (+) wire.
2. Green – Receive negative (-) wire.
3. White – Transmit positive (+) wire.
4. Brown – Transmit negative (-) wire.

The NMEA wires should be connected to a compatible **NMEA 0183** device as shown in the table below:

NMEA 0183 wires		NMEA 0183 device
Yellow – Receive positive (+)	to	Transmit positive (+)
Green – Receive negative (-)	to	Transmit negative (-)
White – Transmit positive (+)	to	Receive positive (+)
Brown – Transmit negative (-)	to	Receive negative (-)

4.9 Connecting an antenna

The radio must be connected to a suitable antenna (not supplied). The antenna connection must be protected so it cannot come into contact with any bare metal (which may be grounded). A protective boot is supplied that can be used to ensure isolation of the antenna connection.

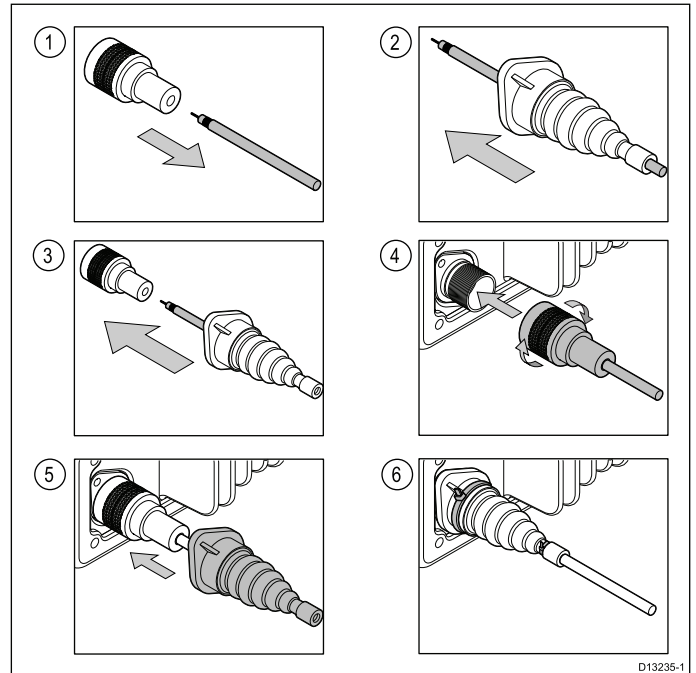

1. Disconnect your antenna cable from the connector.
2. Push the antenna cable through the supplied protective boot.
3. Re-connect the antenna cable to the connector.
4. Plug the antenna connector into the product's antenna connection and secure by tightening the locking collar.
5. Push the protective boot over the connection.
6. Secure the protective boot using the supplied cable ties.

If the antenna connector cannot be removed then another suitable means of protection must be used, such as electrical tape.

4.10 Second handset station — Ray60 / Ray70

The Raymic handset accessory can be connected to the second station connector located on the rear of the radio, this will create a second fully functional station.

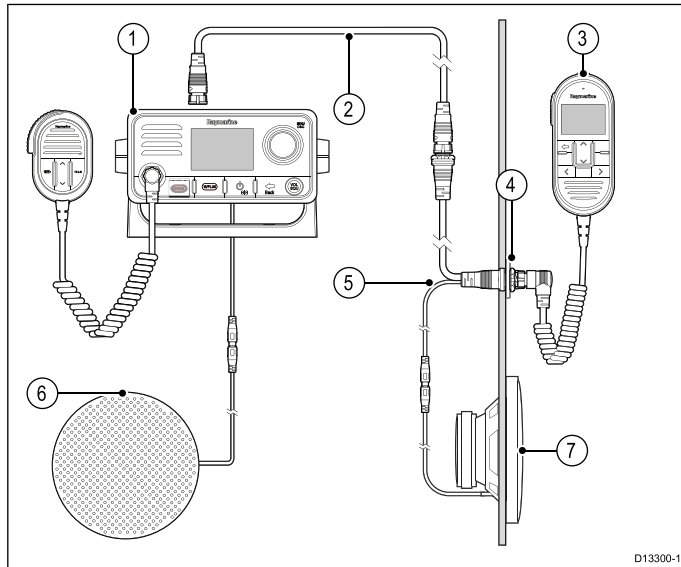

1. Primary station.
2. Raymic handset extension cable (A80290, A80291 or A80292)
3. Raymic handset second station (A80289)
4. Panel mount fixings kit (R70438)
5. Raymic handset adaptor cable with RCA audio (A80297)
6. Primary station passive speaker
7. Second station passive speaker

Note: As the Fistmic does not include a display it cannot be used to create a second functional station.

4.11 Passive speaker connection

A passive speaker can be connected using the RCA lead on the radio or on the handset adaptor cable.

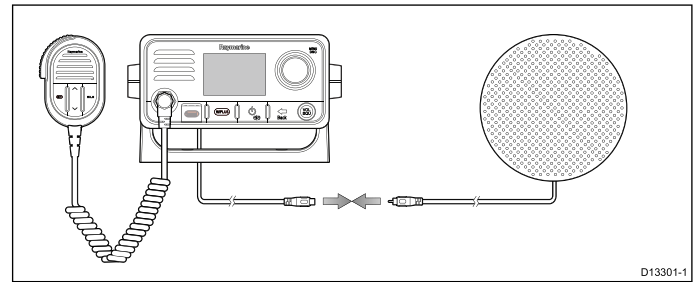

4.12 Loud hailer connection

A single loud hailer can be connected to the radio using the dedicated loud hailer wires.

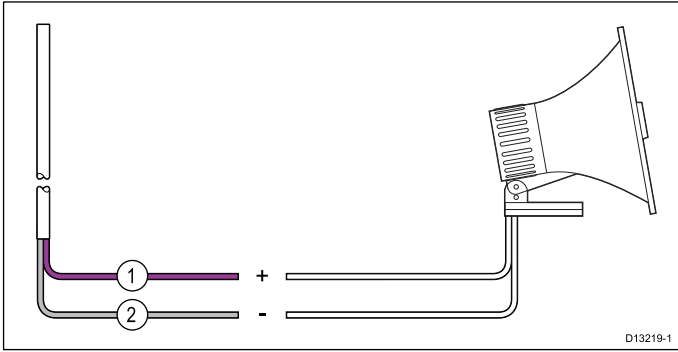

1	(+) Hailer wire (Purple)
2	(-) Hailer wire (Gray)

Loud hailer wires should be connected securely and covered to prevent corrosion.

SWIB

Chapter 5: Location and mounting

Chapter contents

- 5.1 Bracket mounting on page 38
- 5.2 **Ray50** Panel mounting on page 38
- 5.3 **Ray60 / Ray70** Panel mounting on page 40
- 5.4 Fismic / Handset mounting on page 41
- 5.5 **Ray60 / Ray70** Raymic handset cradle mounting on page 41
- 5.6 Pass-through panel kit mounting on page 42

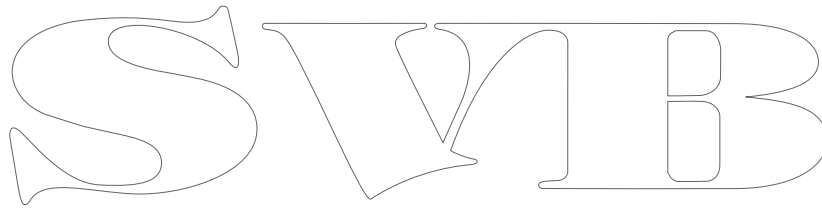

5.1 Bracket mounting

Follow the steps below to mount the product on its bracket.

Before mounting the unit ensure that you have:

- Selected a suitable location, ensuring there is nothing behind the mounting surface that may be damaged when drilling.
- Identified the cable connections and route that the cables will take.
- Attached the front bezel.

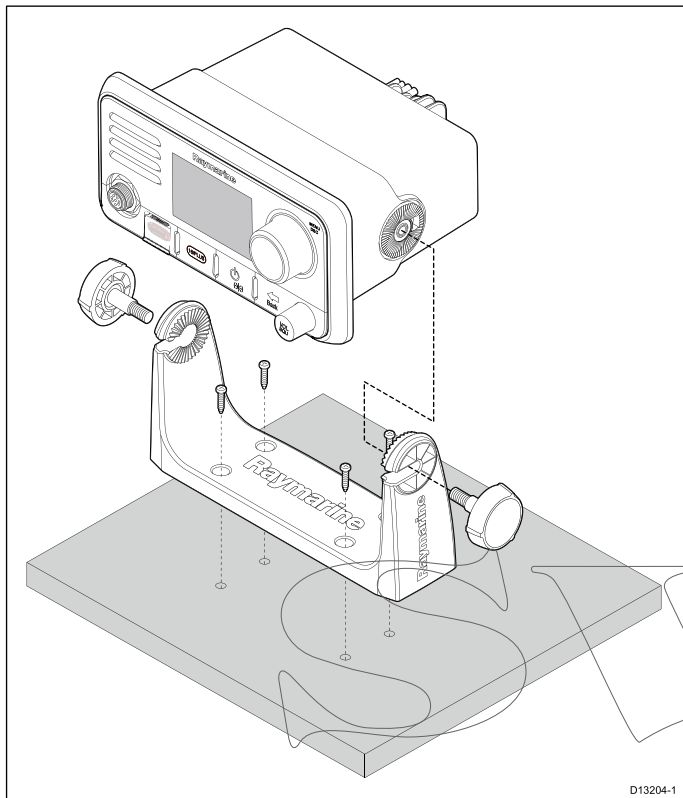

1. Mark the location of the bracket mounting holes on the mounting surface.
2. Drill holes for the mounting fixings using a drill with a suitable sized drill bit.
3. Use the fixings provided to attach the bracket securely to the mounting surface.
4. Attach the unit to the bracket and secure in place using the bracket mounting knobs.

Note: Drill bit, tap size and tightening torque is dependent on the thickness and type of material the unit is to be mounted on.

5.2 Ray50 Panel mounting

Removing the mounting hole covers — Ray50

Before the **Ray50** can be panel mounted the mounting hole covers must be removed.

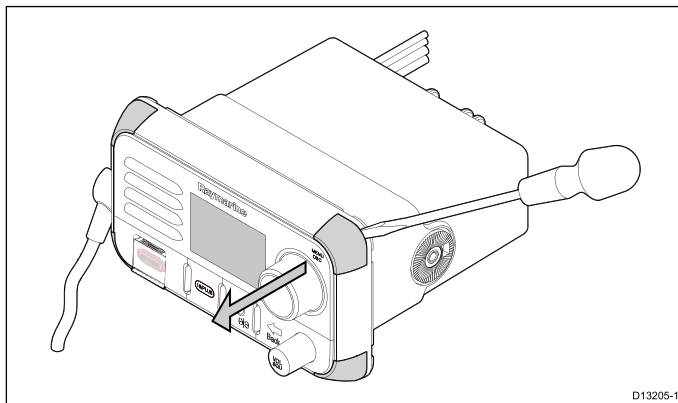

1. Using a flat blade screw driver, insert the tip of the screw driver in the slot between the back of the cover and the unit.
2. Carefully lever the cover forward away from the unit.
3. Repeat steps 2 and 3 for the remaining mounting hole covers.

Drilling out the mounting holes – Ray50

The mounting holes must be drilled out.

Guides for the mounting holes can be found on the corners of the unit, under the mounting hole covers.

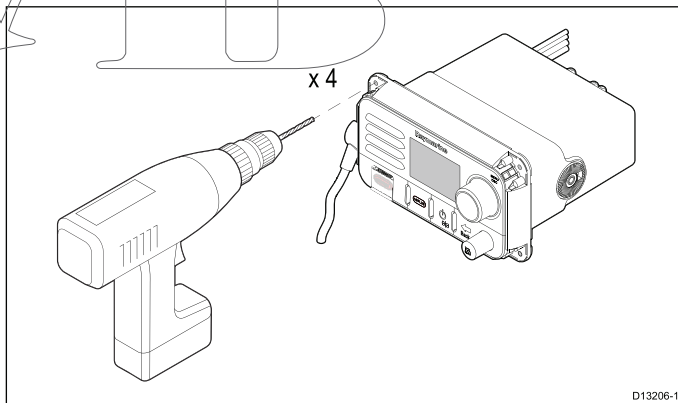

1. Using a drill and a 4 mm (5/32) drill bit, drill out the 4 mounting holes.

Holes should be drilled from the front of the unit, taking care not to damage the unit by applying too much force to the drill.

Panel mounting the Ray50

To panel mount the **Ray50** follow the steps below.

Before mounting the product, ensure that you have:

- Selected a suitable location, ensuring there is nothing behind the mounting surface that may be damaged when drilling / cutting.
- Identified the cable connections and route that the cables will take.
- Removed the mounting hole covers.
- Drilled out the mounting holes on the unit.

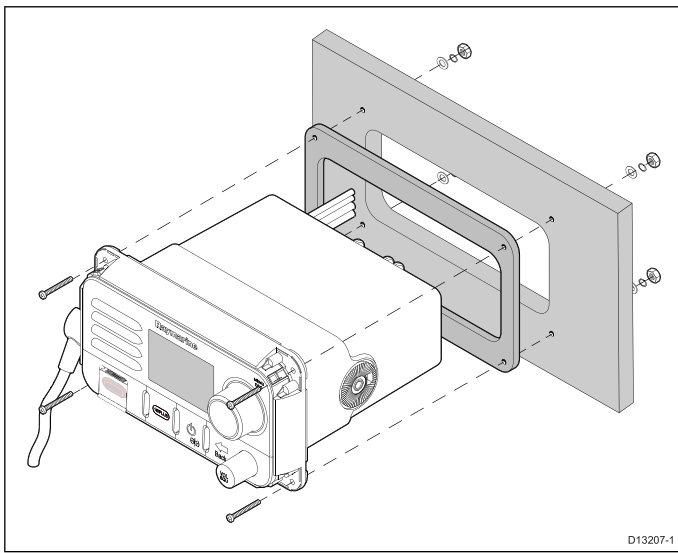

Note: The supplied gasket provides a seal between the unit and a suitably flat and stiff mounting surface or binnacle. The gasket should always be used. It may also be necessary to use a marine-grade sealant if the mounting surface or binnacle is not entirely flat and stiff or has a rough surface finish.

1. Check the selected location for the unit. A clear, flat area with suitable clearance behind the panel is required.
2. Fix the supplied mounting template to the selected location, using masking or self-adhesive tape.
3. Using a suitable hole saw (the size is indicated on the template), make a hole in each corner of the cut-out area.
4. Using a suitable saw, cut along the inside edge of the cut-out line.
5. Ensure that the unit fits into the removed area and then file around the rough edge until smooth.
6. Drill 4 holes as indicated on the template to accept the fixings.
7. Remove the backings from the supplied gasket.
8. Place the gasket in position on the back of the unit and press firmly onto the flange.
9. Connect the power, and other cables to the unit.
10. Slide the unit into place and secure using the fixings provided.
11. Attach the mounting hole covers.

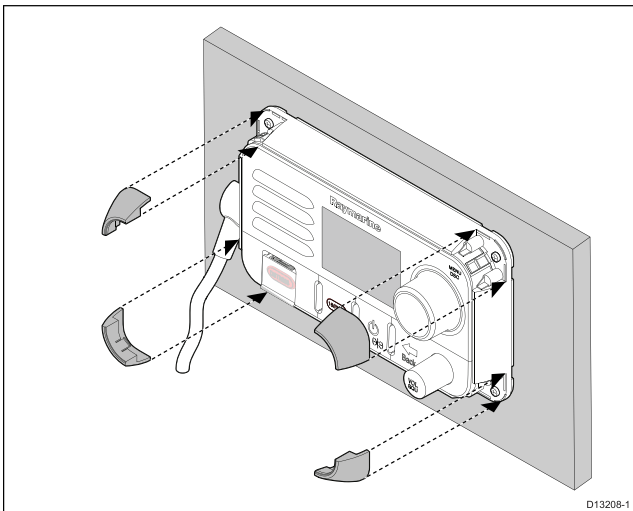
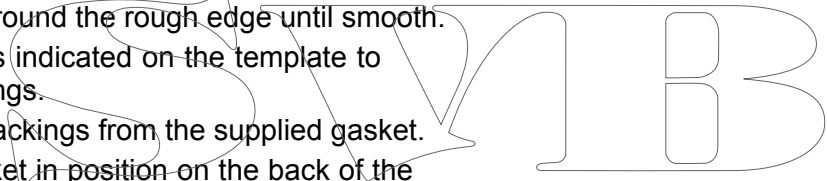

5.3 Ray60 / Ray70 Panel mounting

Drilling out the mounting holes – Ray60 / Ray70

Before panel mounting the product the mounting holes must be drilled out.

Guides for the mounting holes can be found in the corners of the unit, under the front bezel.

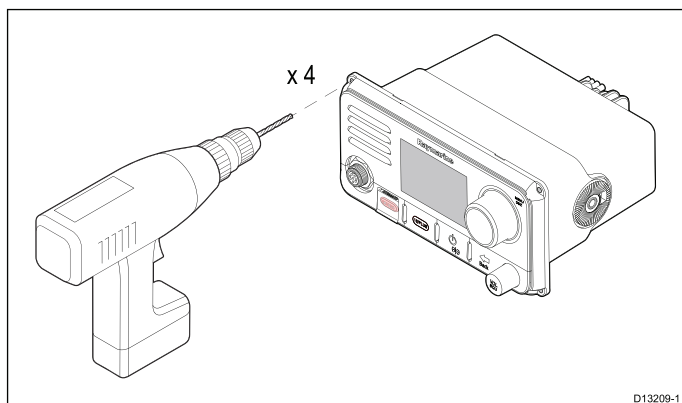

1. Using a drill and a 4 mm (5/32) drill bit, drill out the 4 mounting holes.

Holes should be drilled from the front of the unit, taking care not to damage the unit by applying too much force to the drill.

Panel mounting – Ray60 / Ray70

To panel mount the **Ray60 / Ray70** follow the steps below.

Before mounting the product, ensure that you have:

- Selected a suitable location, ensuring there is nothing behind the mounting surface that may be damaged when drilling / cutting.
- Identified the cable connections and route that the cables will take.
- Drilled out the mounting holes on the unit.
- Removed the front bezel.

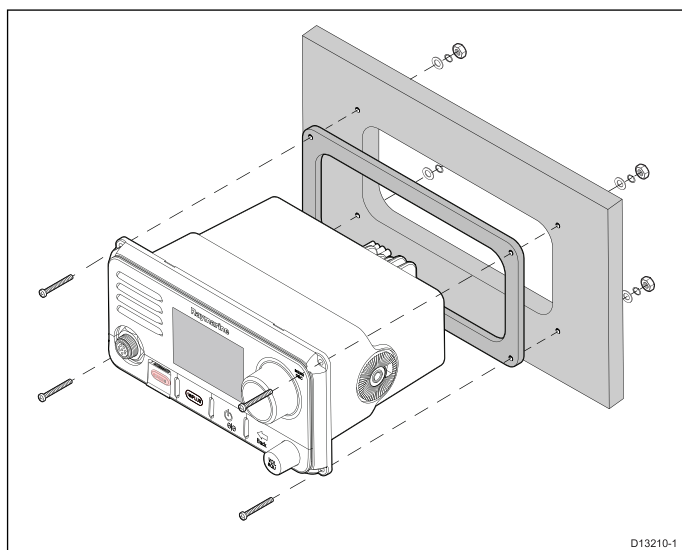

1. Check the selected location for the unit. A clear, flat area with suitable clearance behind the panel is required.
2. Fix the supplied mounting template to the selected location, using masking or self-adhesive tape.

3. Using a suitable hole saw (the size is indicated on the template), make a hole in each corner of the cut-out area.
4. Using a suitable saw, cut along the inside edge of the cut-out line.
5. Ensure that the unit fits into the removed area and then file around the rough edge until smooth.
6. Drill 4 holes as indicated on the template to accept the fixings.
7. Remove the backings from the supplied gasket.
8. Place the gasket in position on the back of the unit and press firmly onto the flange.
9. Connect the power, and other cables to the unit.
10. Slide the unit into place and secure using the fixings provided.
11. Attach the front bezel.

Note: The supplied gasket provides a seal between the unit and a suitably flat and stiff mounting surface or binnacle. The gasket should always be used. It may also be necessary to use a marine-grade sealant if the mounting surface or binnacle is not entirely flat and stiff or has a rough surface finish.

Attaching the front bezel – Ray60 / Ray70

After installation the front bezel can be attached following the steps below.

The following procedure assumes that the unit has already been mounted in position.

1. Orientate the bottom-right side of the bezel under the bottom-right side of the unit, ensuring that the clips along the bottom edge of the bezel latch into position.

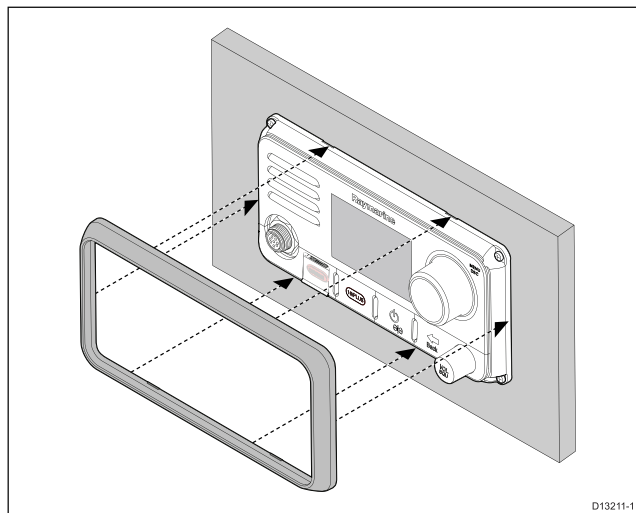

2. Ensure the bezel is correctly aligned with the unit, as shown.
3. Apply firm but even pressure to the bezel along the:
 - i. Outer edges - work from the sides upwards and then along the top edge, to ensure that it clips securely into position.
 - ii. Inner edges - ensure that the bezel sits flat.
4. Check that all control buttons are free to operate.

5.4 Fistmic / Handset mounting

The Fistmic and optional Handset can be mounted by following the steps below. Whilst only the Fistmic is pictured below the steps are identical when mounting the Handset using the mounting clip.

Before mounting the unit, ensure that you have:

- Selected a suitable location, ensuring there is nothing behind the mounting surface that may be damaged when drilling.
- Identified the cable connections and route that the cables will take.

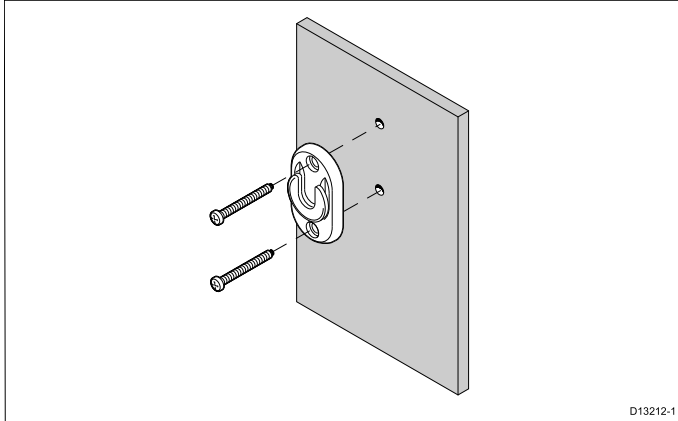

1. Check the selected location for the mounting clip, a clear flat area is required, with sufficient space around it to place and remove the Fistmic / Handset.
2. Using a pencil, offer up the mounting clip to the desired location and mark the location of the screw holes on the mounting surface.
3. Drill the mounting holes using a suitable size drill bit.
4. Hold the clip in place and secure using the screws provided.
5. Hook the Fistmic / Handset over the clip and gently push down until it clicks into position.

Note: The Fistmic can only be hooked and unhooked from the mounting clip when held vertical.

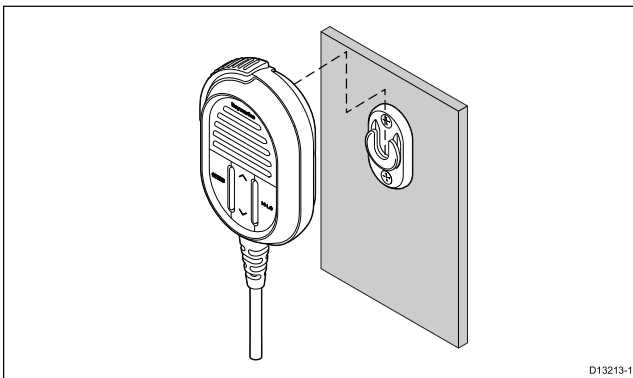

Note: Drill bit, tap size and tightening torque is dependent on the thickness and type of material the unit is to be mounted on.

5.5 Ray60 / Ray70 Raymic handset cradle mounting

Before mounting the unit, ensure that you have:

- Selected a suitable location, ensuring there is nothing behind the mounting surface that may be damaged when drilling.
- Identified the cable connections and route that the cables will take.

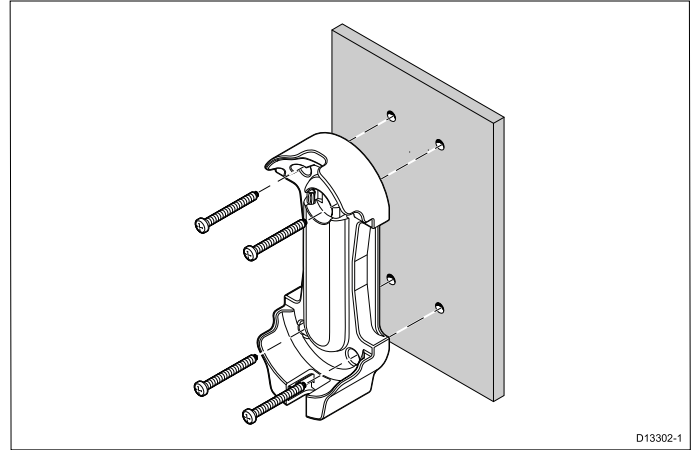

1. Check the selected location for the mounting clip, a clear flat area is required, with sufficient space around it to place and remove the Handset.
2. Using a pencil, offer up the cradle to the desired location and mark the location of the screw holes on the mounting surface.
3. Drill the mounting holes using a suitable size drill bit.
4. Hold the cradle in place and secure using the screws provided.
5. Place the Handset into the cradle until it clicks into position.

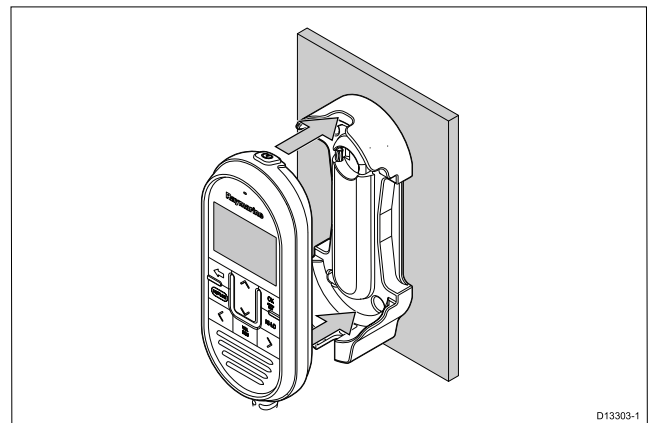

5.6 Pass-through panel kit mounting

When installing the Raymic handset or Fistmic use the, pass-through panel kit to secure the cable through a panel (e.g. bulkhead).

Note: Drill bit, tap size and tightening torque is dependent on the thickness and type of material the unit is to be mounted on.

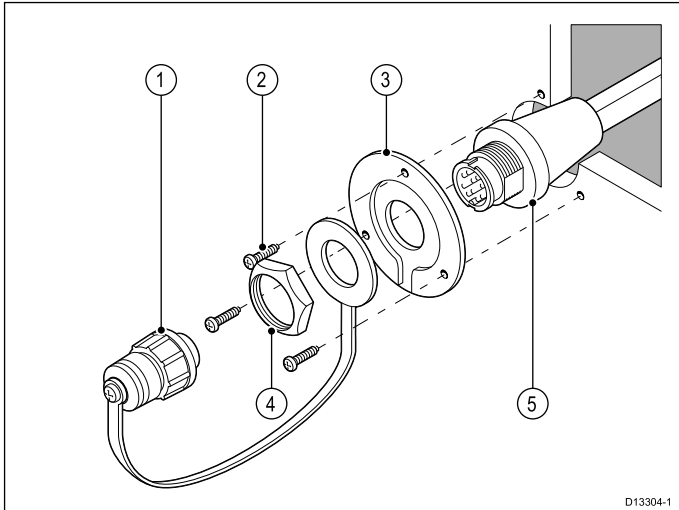

D13304-1

1	Splash-proof cap
2	Mounting screws x3
3	Mounting plate
4	Nut
5	Extension cable connector

1. Check the selected location for the handset extension mounting plate, a clear flat area is required.
2. Using a pencil, offer up the mounting plate to the desired location and mark the location of the screw holes and the center hole on the mounting panel.
3. Drill the mounting holes using a suitable size drill bit.
4. Drill the center hole using a 25 mm (1 in.) hole cutting saw.
5. Pull the connector end of the cable through the hole in the mounting panel.
6. With the recessed side facing away from the mounting panel, place the mounting plate over the end of the connector.
7. Place the ring end of the lanyard over the connector, ensuring the lanyard sits in the recess in the mounting plate.
8. Place the nut over the connector and tighten clockwise using a 13/16 in. (21 mm) socket wrench, being careful not to damage the nut by overtightening.
9. Secure the mounting plate to the mounting surface using the supplied screws.
10. Attach the handset / Fistmic connector to the cable connector and rotate the locking collar clockwise to secure.
11. Connect the opposite end of the cable to the required connector either on the base station or to another pass-through panel mounting plate connector.

Chapter 6: Getting started

Chapter contents

- 6.1 Controls and interface on page 44
- 6.2 Powering the unit on on page 44
- 6.3 Powering the unit off on page 45
- 6.4 Homescreen overview on page 45
- 6.5 Shortcut list on page 47
- 6.6 Initial startup on page 48
- 6.7 Accessing the menu on page 48
- 6.8 Selecting a language on page 49
- 6.9 Switching on the AIS receiver — **Ray70** on page 49
- 6.10 Selecting a network type on page 50
- 6.11 Entering your MMSI number on page 50
- 6.12 Enabling and disabling ATIS mode on page 51
- 6.13 Entering your ATIS ID on page 52
- 6.14 Changing the radio region on page 53
- 6.15 Adjusting the display brightness on page 53
- 6.16 Adjusting the display contrast on page 54
- 6.17 Switching between high and low transmit power on page 54
- 6.18 GPS/GNSS setup on page 55
- 6.19 Station priority - **Ray60** and **Ray70** on page 56

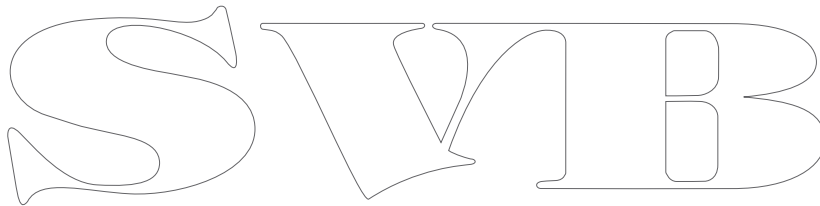

6.1 Controls and interface

The controls and interface available are as follows:

Base station

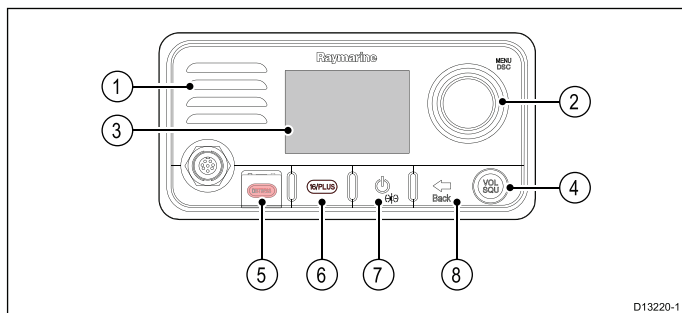

1. **Built-in speaker**
2. **Rotary knob / OK push button** — Press knob in to access menu / DSC functions and to confirm selections. Turn rotary clockwise or anti-clockwise to move up and down through menu items or to change channel from the Homescreen.
3. **LCD**
4. **VOL/SQ** — Turn knob to adjust volume or squelch up and down. Press center button to switch between volume and squelch control.
5. **DISTRESS** — Push up the spring loaded cover and press this button to make a DSC distress call.
6. **16 / PLUS** — When powered on press to switch between priority channels.
7. **Power** — Press to power the unit on. Press and hold for 3 seconds to power the unit off. Momentary press to access the shortcut list.
8. **Back** — Move back through menu options.

Fistmic

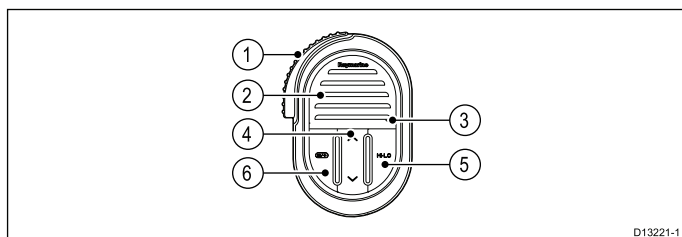

1. **PTT (Push to Talk)** — Press and hold to send a voice message. Release to return to receive mode.

Note: The maximum transmit time is limited to 5 minutes to prevent un-intentional transmissions from occupying the VHF channel.

2. **Speaker**
3. **Microphone location**
4. **Channel Up and Down** — Changes the channel up or down.
5. **HI/LO** — Press to switch between High (25 W) and low (1 W) transmit power.
6. **16 / PLUS** — When powered on press to switch between priority channels.

6.2 Powering the unit on

With the radio connected to a power supply the power button is used to switch the radio on and off.

1. Press the **Power** button to power-up the radio.

The startup is displayed.

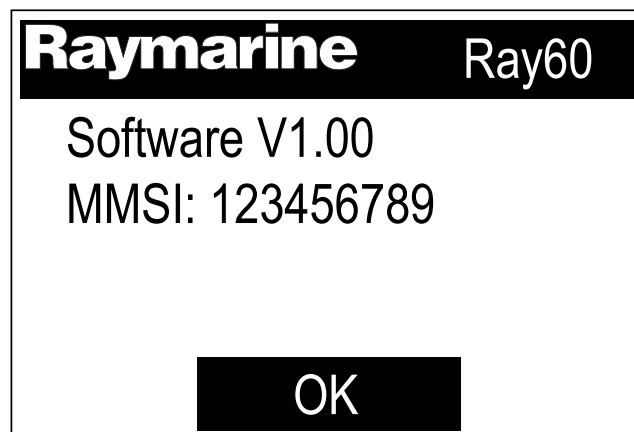

The startup screen will automatically time-out after 5 seconds.

2. Press the **OK** button, or wait for the startup screen to time-out.

The Homescreen is displayed.

6.3 Powering the unit off

With the unit powered on:

1. Press and hold the **Power** button for approximately 3 seconds to power the unit off.

6.4 Homescreen overview

The information below describes the on-screen characters and symbols which the radio displays on the main screen and what they mean.

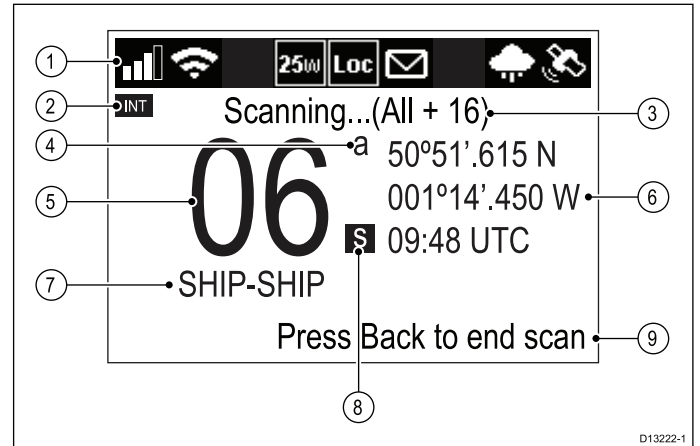

1. **Status bar** — The status bar displays symbols which indicate the current status of the unit. See [Status bar symbols](#) for details.
2. **Frequency band** — Indicates which channel frequency band is in use:
 - **USA** — United States of America
 - **INT** — International
 - **CAN** — Canada
 - **WX** — Weather

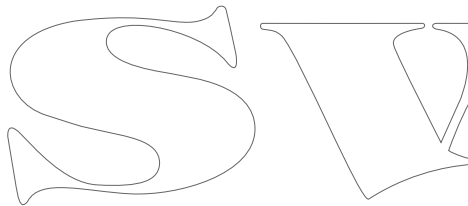

Note: Special licensing is required to receive USA and Canadian channel sets.

3. **Status text** — Indicates the current radio mode e.g.: ATIS Mode active, Weather Alert, Scan mode etc.
4. **Channel suffix**
 - **a** — Indicates that the current US or Canadian channel is simplex. This channel uses the transmit frequency of the International channel for transmitting and receiving. If a channel is simplex in all 3 frequency bands (e.g. channel 06, the channel does not require the **a** suffix.
 - **b** — Indicates that the channel is a receive only channel. Used for Canadian channels only.

Note: You cannot transmit on a receive only channel.

5. **Channel** — Indicates the current channel number
6. **Location / Time** or **Location / COG/SOG** — Depending on selection displays Location coordinates and current time or Location coordinates and current COG and SOG.
7. **Channel Name** — Indicates the name of the current channel.
8. **Channel type** — Indicates the type of channel:
 - **s** = Simplex — Simplex channels transmit and receive on the same frequency.
 - **d** = Duplex — Duplex channels use separate frequencies to transmit and receive.

9. **Optional text** — Provides extra user guidance

Status bar symbols

The status bar is used to display icons that indicate the radio's status.

Symbol	Name	Description
	Reception signal	Indicates the relative strength of the radio signal being received. Displays between 0 bars (no transmission being received) and 4 bars (strong reception signal).
	Transmit	Indicates the radio is currently transmitting (e.g. the PTT button is being pressed.)
	Receive	Indicates the radio is currently receiving a transmission
	Low power	Indicates the radio transmitters is in low power (1 watt) or high power (25 watt) mode
	High power	
	Local	Indicates the radio is in local reception mode, which decreases receiver sensitivity in high traffic areas to decrease unwanted reception
	DSC	Indicates that a DSC call has been received
	Power supply voltage too low	Indicates the power supply to the radio is below the specified operating voltage
	Power supply voltage too high	Indicates the power supply to the radio is above the specified operating voltage

Symbol	Name	Description
	Weather	Indicates that the weather alerts mode is activated.
	GPS Fix	Indicates if the radio has a GPS/GNSS fix.

Main menu overview



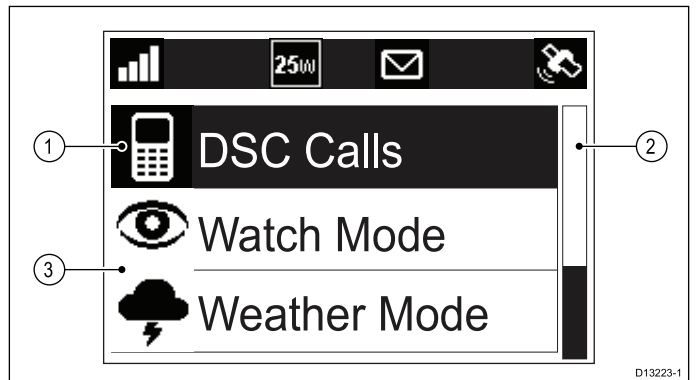

The main menu is accessed by Pressing the **OK** button from the **Homescreen**.



1. Currently selected menu item
2. Scroll bar
3. Menu items

The main menu includes the following items:

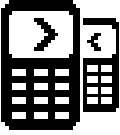
Symbol	Name	Sub-options
	* DSC Calls	<ul style="list-style-type: none"> • Individual call • Distress call • Position request • Group call • All ships call • Phonebook • Call logs • Test call • DSC set-up
	* Watch Mode	<ul style="list-style-type: none"> • Dual watch • Triple watch • 2nd priority channel
	* Weather Mode	<ul style="list-style-type: none"> • Weather Homescreen

Symbol	Name	Sub-options
	* Scan Mode	<ul style="list-style-type: none"> • All channels • All channels + 16 • Saved channels • Saved channels + 16 • Edit saved channels
	** Hail/Fog/Intercom	<ul style="list-style-type: none"> • Hailer • Fog horn • Intercom
	** Hailer/Fog horn	<ul style="list-style-type: none"> • Hailer • Fog horn
	** Intercom	<ul style="list-style-type: none"> • Intercom
	Set-up	<ul style="list-style-type: none"> • Display set-up • Language • Units • Power output • Sensitivity • Key beep • Channel set-up • Weather alerts • GPS set-up • DSC set-up • AIS • Network output • ATIS set-up • Maintenance

Note:

* Menu items not available when radio has ATIS enabled or if the radio has been pre-programmed in MARCOM-C mode.

** The menu name and sub-options depend on the peripheral devices connected to the radio.

6.5 Shortcut list

Pressing the **Power** button once while the radio is switched on will open the **Shortcuts list**. The Shortcuts list can be used to adjust the brightness, contrast and access frequently used functions.

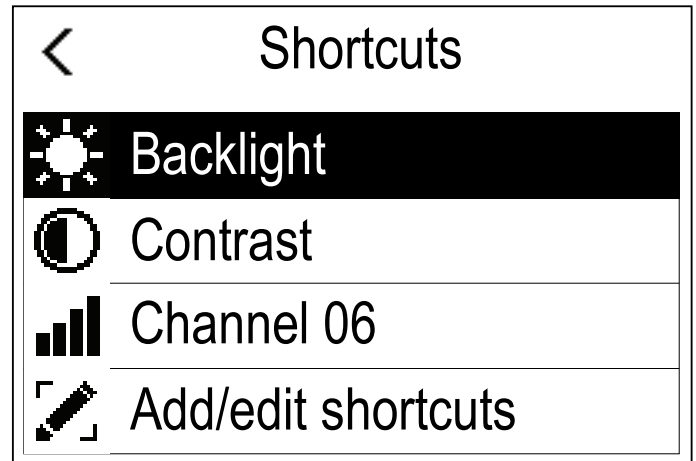

Frequently used functions can be added by selecting **Add/edit shortcuts**.

Adjusting Brightness and Contrast

The LCD Brightness and Contrast can be adjusted using the Shortcuts list.

From any screen:

1. Press the **Power** button.
2. Select **Brightness** or **Contrast**.
3. Use the **Rotary knob** to adjust the Brightness or Contrast to the desired level.
4. Press the **Power** button again to return to the previous screen.

6.6 Initial startup

Unless your radio has been pre-programmed; the first time you power-up your radio you will be requested to select certain options. With the exception of your MMSI and ATIS ID, you will also be requested to enter these options after a factory reset.

After acknowledging the startup screen, unless previously set you will be prompted to make the following selections:

1. Language selection

See [6.8 Selecting a language](#) for available languages.

2. Turn on AIS reception — Ray70 only

Enables the built-in AIS receiver. This step is only applicable to radios with a built-in AIS receiver. See [6.9 Switching on the AIS receiver](#) for more information.

3. Select network type

Selects which connection to transmit AIS and DSC information to connected equipment on. This step is only applicable if the AIS receiver was turned on in the previous step. See [6.10 Selecting a network type](#) for available options.

4. Enter MMSI number

Required to enable DSC functions. This option is not required after a factory reset, or if the radio has been pre-programmed in MARCOM-C mode, or has ATIS enabled. See [6.11 Entering an MMSI number](#) for more information. If not already selected you will also be prompted to select your network type.

5. Enter ATIS ID

Required when the radio will be used in the inland waterways of Europe. This step is only applicable if the radio has been pre-programmed in MARCOM-C mode. See [6.13 Entering an ATIS ID](#) for more information.

6. Frequency band selection

Sets the relevant channels for your region. This step is not applicable if the radio has been pre-programmed in MARCOM-C mode. See [6.14 Changing the radio region](#) for more information.

6.7 Accessing the menu

The radio's various options and settings are contained within the menu.

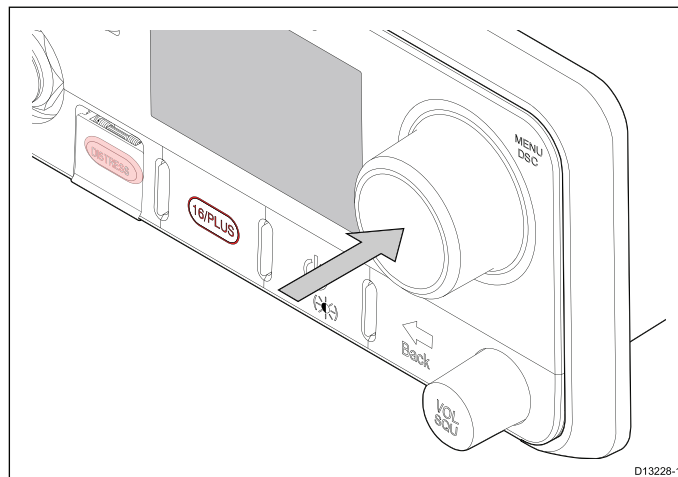

From the Homescreen.

1. Press the **Rotary knob's OK** push button.

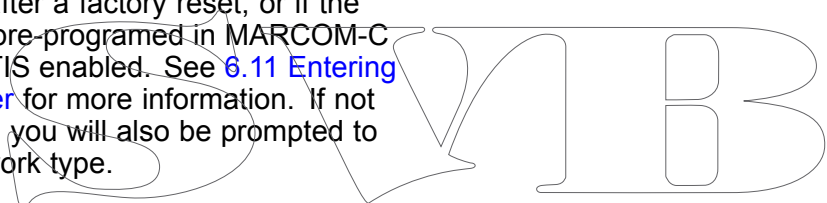

6.8 Selecting a language

The language the radio uses can be changed.

From the Main menu:

1. Select **Set-up**.
2. Select **Language**.

The languages available are:

- **English (default)** — English
 - **Español** — Spanish
 - **Français** — French
 - **Deutsch** — German
 - **Italiano** — Italian
3. Select the language that you want the radio to be set to.

The User interface language is changed to the selected language.

6.9 Switching on the AIS receiver — Ray70

The **Ray70**'s AIS receiver can be switched on or off.

From the Main menu:

1. Select **Set-up**.
2. Select **AIS**.
3. Select **On**.

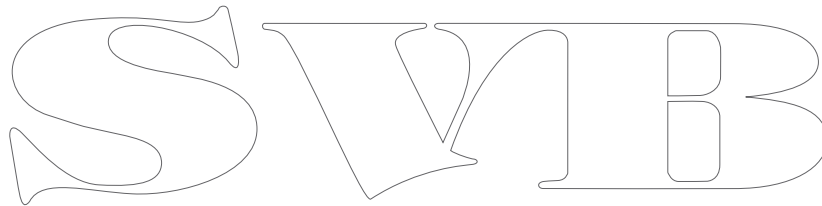

6.10 Selecting a network type

When connecting your radio to other devices it is important to ensure you select the network connection and type that you want data to be transmitted over.

From the Main menu:

1. Select **Set-up**.
2. Select **Network output**.

The following network types are available:

- **NMEA 2000 (default)**
- **0183 High speed**
- **0183 Std speed**

3. Select the network type relevant to the devices connected to your radio. If your radio is not connected to any other devices any option can be selected.

Selecting **0183 Std speed** will disable the internal AIS receiver on a **Ray70**.

The **Network output** setting determines the baud rate of the **NMEA 0183** input:

Network output setting	NMEA 0183 input baud rate
NMEA 2000	Standard speed (4800)
NMEA 0183 High Speed	High speed (38400)
NMEA 0183 Standard Speed	Standard speed (4800)

6.11 Entering your MMSI number

To program your radio with your MMSI number follow the steps below.

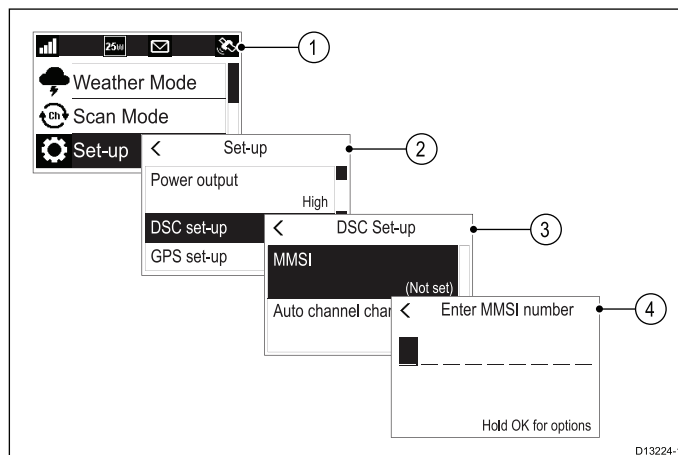

From the Main menu:

1. Select **Set-up**.
2. Select **DSC set-up**.
3. Select **MMSI**.

(Not set) will be displayed if no MMSI number has been set.

4. Use the **Rotary knob** to cycle through the available numbers and press **OK** to confirm each number and move to the next digit.

You should only enter the unique 9 digit MMSI number provided by your licensing authority.

MMSI numbers starting with a '0' are only used for groups and coast stations. If you enter a '0' as the first digit the radio will assume you are entering a coast station MMSI and automatically assign a '0' as the second digit; this is to ensure a group MMSI is not entered as the radio's unique MMSI.

5. Press the **Back** button at any time to edit digits you have already entered.
6. Press and hold the **OK** button to display options to **Move cursor** back and forward through the digits.
7. When the final digit is confirmed select **DONE**.

Example

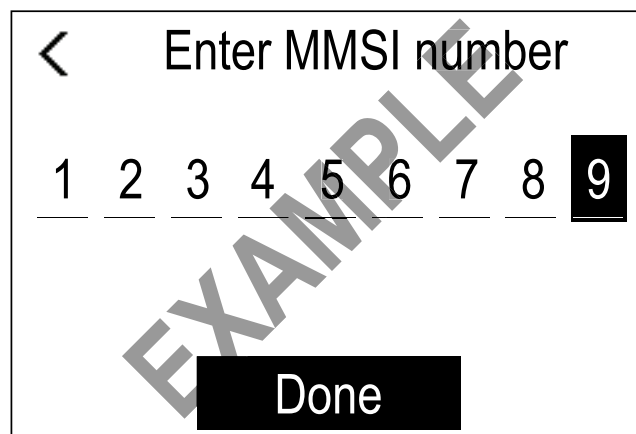

8. The MMSI is displayed onscreen, check that it is correct, then:
 - i. Select **Yes – Save**, or

- ii. if the number entered is not correct select **No** – **Retry**.

Caution: MMSI and ATIS ID entry

You can only enter the MMSI number and ATIS ID once!

If you store an incorrect MMSI number or ATIS ID in your product, it will have to be reset by an authorized **Raymarine®** dealer.

6.12 Enabling and disabling ATIS mode

ATIS is a European system used on some inland waterways. ATIS must be enabled and a unique ATIS ID entered in order to use ATIS mode.

From the Main menu.

1. Select **Set-up**.
2. Select **ATIS set-up**.
3. Select **ATIS**.
4. Select **On** to enable ATIS mode or **Off** to disable ATIS mode.

With ATIS mode enabled the radio's region will be fixed to the INT (international) frequency band and the following functions are disabled:

- DSC functions
- Watch Mode
- Scan Mode
- High/low power is restricted on certain channels

Once ATIS has been enabled an ATIS ID must be entered.

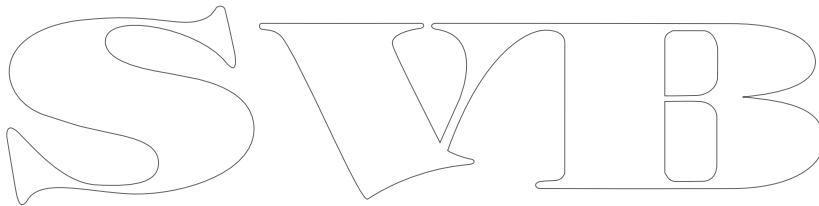
The image shows the letters 'SVIB' in a large, stylized, outlined font. The letters are white with a black outline, set against a plain white background. The 'S' is a simple cursive-like shape, the 'V' is a simple inverted 'V', the 'I' is a simple vertical bar, and the 'B' is a simple block letter.

6.13 Entering your ATIS ID

When ATIS mode is enabled a unique ATIS ID must be entered.

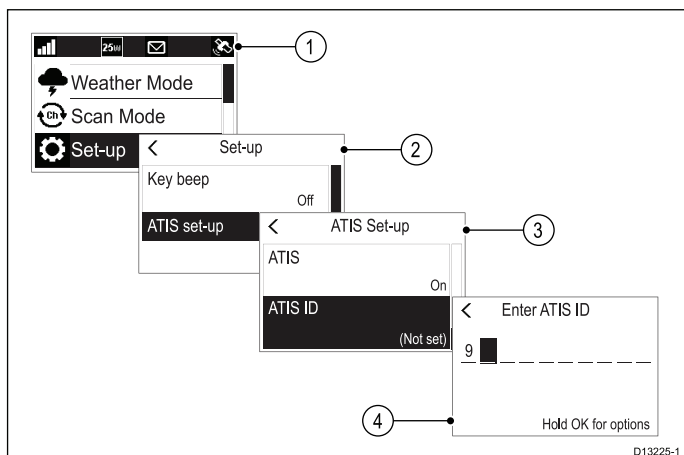

9. The ATIS ID is displayed onscreen, check that it is correct, then:
 - i. Select **Yes – Save**, or
 - ii. if the number entered is not correct select **No – Retry**.

Caution: MMSI and ATIS ID entry

You can only enter the MMSI number and ATIS ID once!

If you store an incorrect MMSI number or ATIS ID in your product, it will have to be reset by an authorized **Raymarine®** dealer.

From the Main menu.

1. Select **Set-up**.
2. Select **ATIS set-up**.
3. Select **ATIS ID**.

(Not set) will be displayed if no ATIS ID has been set.

The first digit is set to a '9' and cannot be changed, this is because all ATIS IDs start with a '9'.

As most ATIS IDs consist of a '9' followed by your 9 digit MMSI number; if your radio already has an MMSI number the ATIS ID will be pre-filled in this format.

4. If the ATIS ID has been pre-filled, check it carefully against your issued ATIS ID.
5. To enter your ATIS ID manually, use the **Rotary knob** to cycle through the available numbers and press **OK** to confirm each number and move to the next digit.

You should only enter the unique 10 digit ATIS ID provided by your licensing authority.

6. Press the **Back** button at any time to edit digits you have already entered.
7. Press and hold the **OK** button to display options to **Move cursor** back and forward through the digits.
8. When the final digit is confirmed select **DONE**.

Example

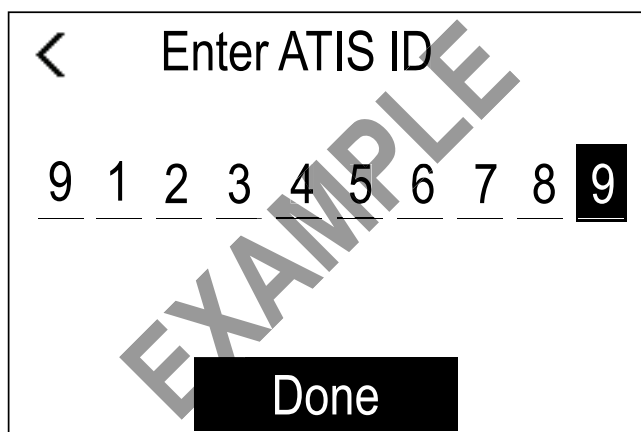

6.14 Changing the radio region

Prior to using the radio you must set the Frequency band to the region your radio will be used in.

From the Main menu:

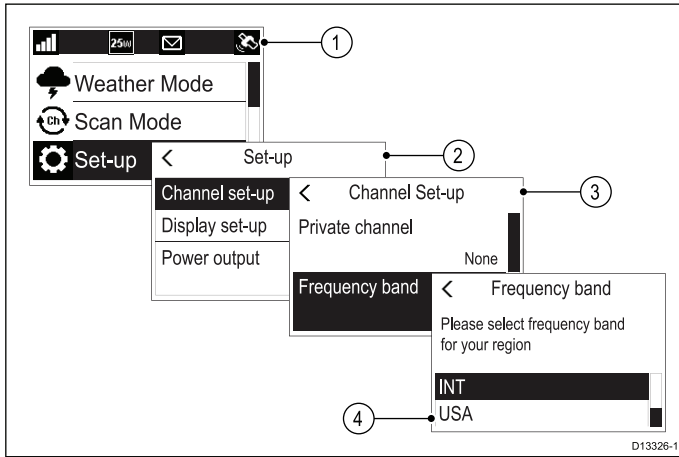

1. Select **Set-up**.
2. Select **Channel set-up**.
3. Select **Frequency band**.
4. Select the relevant region from the list.

The available options are:

- **USA**
- **INT** = International
- **CAN** = Canada

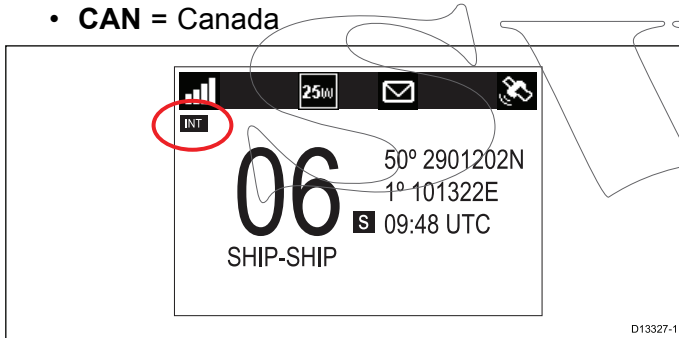

6.15 Adjusting the display brightness

The display's brightness level can be adjusted by following the steps below.

From the **Display set-up** menu: **Menu > Set-up > Display set-up**:

1. Select **Brightness**.
2. Use the **Rotary knob** to adjust the display's brightness to the required level.

6.16 Adjusting the display contrast

The display's contrast level can be adjusted by following the steps below.

From the **Display set-up** menu: **Menu > Set-up > Display set-up:**

1. Select **Contrast**.
2. Use the **Rotary knob** to adjust the display's contrast to the required level.

6.17 Switching between high and low transmit power

You can switch between high (25 W) and low (1 W) transmit power using the HI/LO button on the Fismic.

The transmit power can also be changed from the **Set-up** menu: **Menu > Set-up**

1. Select **Power output**.
2. Select **Low** for 1 W transmit power, or
3. Select **High** for 25 W transmit power.

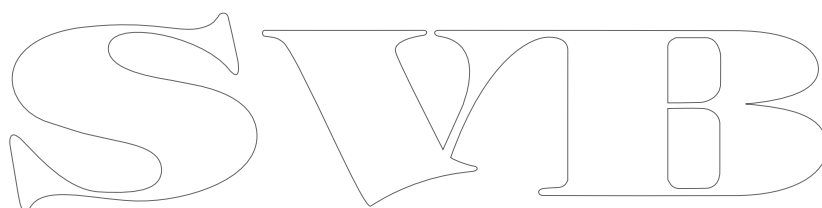
The image shows a stylized outline logo for 'SVIB'. The letters are large, bold, and have a decorative, slightly calligraphic feel. The 'S' is on the left, followed by 'V', 'I', and 'B' on the right. The outlines are thin and black, set against a white background.

6.18 GPS/GNSS setup

If your radio includes an internal GPS/GNSS receiver or if your radio is connected to a GPS/GNSS receiver over **NMEA 0183** or **SeaTalk^{ng}**, the radio can display relevant GPS information.

The following information can be displayed:

- latitude
- longitude
- UTC time
- COG and SOG

When GPS/GNSS data is available the satellite icon is displayed onscreen.

If no GPS/GNSS data is available then the latitude, longitude and time can be entered manually so that it can be included in DSC distress transmissions.

Position data received from other vessels can be displayed on a connected **Raymarine** multifunction display.

Enabling and disabling the internal GPS - Ray70

From the **GPS set-up** menu: **Menu > Set-up > GPS set-up**

1. Select **Internal GPS**.

Selecting **Internal GPS** will switch the internal GPS/GNSS receiver On and Off.

No GPS position data

If no GPS data is available or GPS data becomes unavailable; after 10 minutes an audible warning is sounded, the GPS icon flashes and the **No position data** message is displayed.

Once the warning has been acknowledged the GPS icon will continue to flash. The **No position data** warning is repeated every 4 hours if position data is still unavailable, has not been entered manually or has been entered manually but over 23.5 hours ago.

If position data has been entered manually the display alternates between displaying the manual position and time and the **Manual Position** message. If the manually entered position has not been updated in the last 4 hours the GPS icon flashes and an audible warning is sounded. This warning will be repeated every 4 hours until position is manually updated or GPS position data becomes available.

Where no position data is available or has not been manually updated for 23.5 hours then position data will change to '9's and time will change to '8's.

Entering position manually

If GPS position data is not available it can be entered manually.

From the **GPS set-up** menu: **Menu > Set-up > GPS set-up**.

1. Select **Set manual position**.

The Manual position screen requires you to input latitude, longitude and UTC time.

2. Use the **Rotary knob** to cycle through the available numbers and press **OK** to confirm each number and move to the next digit.
3. When the relevant information has been entered select **OK** to confirm the details.

Selecting GPS information to display

You can change the GPS data that is displayed on the Homescreen.

From the **GPS set-up** menu: **Menu > Set-up > GPS set-up**.

1. Select **Homescreen display**.
2. Select the required option:
 - Location & time
 - Location & COG/SOG

The **Homescreen display** option is also available from the **Display set-up** menu

Setting time format and offset

You can change the Format and Offset that is applied to the time displayed onscreen.

From the **Units** menu: **Menu > Set-up > Units**.

1. Select **Time format**.
2. Select the desired format:
 - 12 hour
 - 24 Hour (default)
3. Select **Time offset**.
4. Adjust the offset to the desired value using the **Rotary knob** or the **Channel Up** and **Channel Down** buttons.
5. Select **OK** to confirm the selection.

6.19 Station priority - Ray60 and Ray70

The **Ray60** and **Ray70** can have both a Local Fismic (connected to the front connector) and a Remote Handset (connected to the rear connector) station.

The following rules apply to station priority:

- The Local station always takes priority over the Remote station.
- Unless a Distress call is in progress, any button press on the Local station will take control from the Remote station.
- If the Remote station is inactive for 3 seconds, the Local station can take control and complete an incomplete Distress call.
- The Local station can interrupt the Remote stations's voice broadcasts by pressing the **PTT** button.
- The Local station will retain control for 3 seconds after the last button press.
- The information on the station which has control is repeated on the other station's display.

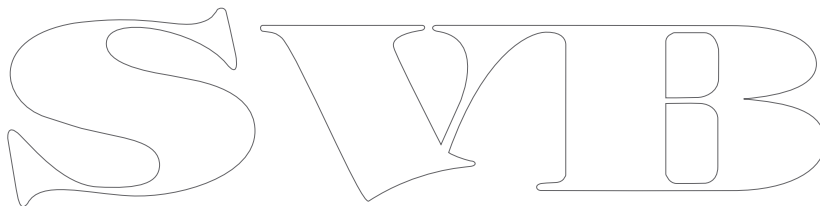

Chapter 7: Digital selective calling (DSC)

Chapter contents

- 7.1 Digital Selective Calling (DSC) on page 58
- 7.2 Distress calls on page 59
- 7.3 Urgency calls on page 61
- 7.4 Safety calls on page 62
- 7.5 Individual (routine) calls on page 62
- 7.6 Group calls on page 63
- 7.7 Position requests on page 64
- 7.8 Phonebook on page 64
- 7.9 Call logs on page 65
- 7.10 Test calls on page 65
- 7.11 DSC set-up menu options on page 66

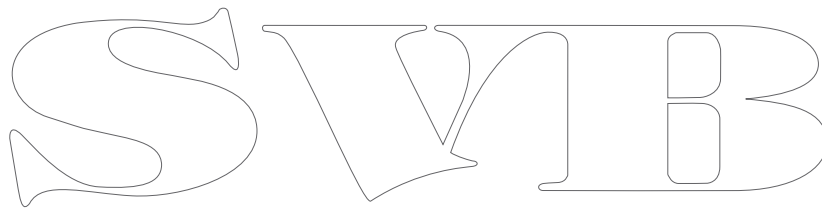

7.1 Digital Selective Calling (DSC)

Traditional VHF radio systems require users to listen until someone speaks, and then determine whether the call is for them. DSC ensures that calls are received by alerting or announcing the intended recipient(s) first so they are ready to listen to the subsequent message on the relevant channel.

DSC is part of the Global Maritime Distress and Safety System (GMDSS), a maritime communications system for emergency and distress messages and all types of routine communications such as ship-to-ship or ship-to-shore.

DSC is a digital signalling system, which operates on VHF channel 70. DSC calls include other data such as your vessel's identification number, purpose of the call, your position and the channel you want to speak on.

DSC calls can be divided into 4 categories and are prioritized as shown below:

1. Distress
2. Urgency
3. Safety
4. Routine

Distress

A Distress call should only be used when there is imminent danger to a vehicle or person that requires immediate assistance.

When making a distress call the following information is transmitted to all stations within range:

- Vessel MMSI number.
- Vessel position (must be input manually if no GPS position data is available).
- Local time (must be input manually if no GPS position data is available).
- Nature of the distress (when designated).
- Transmission frequency.

The call is automatically repeated at approximately 4 minute intervals until it is acknowledged either by a coast radio station (CRS) or a vessel within radio range. Distress calls must be followed by a MAYDAY call on priority channel 16.

Urgency

An urgency call should be used when there is danger to a vehicle or person that does not require immediate assistance.

When making an urgency call the following information is transmitted to all stations within range:

- Vessel MMSI number.
- Vessel position (must be input manually if no GPS position data is available).
- Local time (must be input manually if no GPS position data is available).
- Transmission frequency.

Once an urgency call is sent it must be followed with a PAN PAN voice message on channel 16 and include the necessary details.

Safety

A safety call should be used when there is an important navigational warning or meteorological forecast/broadcast. Safety alerts can also be used for communications during search and rescue operations.

When making a safety call the following information is transmitted to all stations within range:

- Vessel MMSI number.
- Vessel position (must be input manually if no GPS position data is available).
- Local time (must be input manually if no GPS position data is available).
- Transmission frequency.

Once a safety call is sent it must be followed with a SECURITE voice message on channel 16 and include the necessary details.

Routine calls

Routine calls are used for contacting other vessels, marinas, or shore stations.

Routine calls are made on channel 70 using the dedicated Maritime Mobile Service Identity (MMSI) number of the station to be contacted, selecting a VHF working channel and sending the call. Both radios automatically switch to the chosen channel for conversation.

Routine calls can also be made to groups — When groups of ships need the same information (yacht races, club rallies etc.) a special group-call identity can be used to enable restricted broadcast calls.

Note: To transmit precise positions, the radio must be interfaced to a GPS receiver. Otherwise, regular manual position updating is required.

7.2 Distress calls

Making a designated distress call

When making a Distress call you can specify the nature of the distress, if GPS data is not available you must also specify your coordinates.

Note: Your radio must have an MMSI number saved before DSC functions can be used.

From the Distress call menu: **Menu > DSC Calls > Distress Calls**

1. Select a distress type from the list.

- Undesignated
- Fire
- Flooding
- Collision
- Grounding
- Listing
- Sinking
- Adrift
- Abandoning
- Piracy
- Man overboard

If your radio has a GPS fix then the distress type and coordinates are displayed, otherwise you will be prompted to enter your position coordinates.

2. If prompted, enter your position coordinates and local time using the **Rotary knob** or the **Channel Up** and **Channel Down** buttons to enter the relevant details.
3. When complete press the **OK** button.
4. Follow the steps for Making a Distress Call to transmit the distress alert.

Making a distress call

In an emergency you can use your unit to make an automatic DSC distress call.

With the spring loaded cover open:

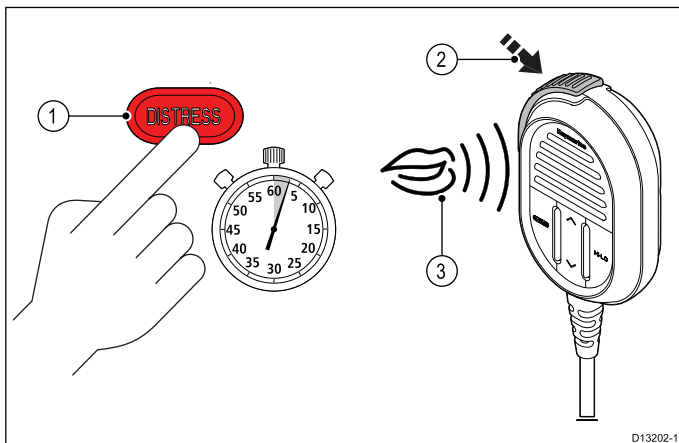

1. Press and hold the **DISTRESS** button for 3 seconds.

Once the **DISTRESS** button is pressed a 3 second count down will begin, when the count

down reaches zero the DSC distress call is transmitted.

The distress call is repeated automatically until it is acknowledged.

2. Press and hold the **PTT** button, then slowly and clearly speak the details of the distress in the following format:

MAYDAY, MAYDAY, MAYDAY

This is <state name of vessel 3 times>

MAYDAY <state name of vessel 1 time>

My position is <state latitude and longitude, or true bearing and distance from a known point.>

I am <state nature of distress e.g. sinking, on fire etc.>

I have <state number of persons on board and any other information — drifting, flares fired etc.>

I REQUIRE IMMEDIATE ASSISTANCE

OVER

3. Release the **PTT** button.

Making a Mayday call

In an emergency you can use your unit to make a Mayday call.

1. Press the **16 PLUS** button.
2. Press and hold the **PTT** button.
3. Slowly and clearly speak the details of the distress:

MAYDAY, MAYDAY, MAYDAY

This is <state name of vessel 3 times>

MAYDAY <state name of vessel 1 time>

My position is <state latitude and longitude, or true bearing and distance from a known point.>

I am <state nature of distress e.g. sinking, on fire etc.>

I have <state number of persons on board and any other information — drifting, flares fired etc.>

I REQUIRE IMMEDIATE ASSISTANCE

OVER

4. Release the **PTT** button.
5. If an acknowledgement is not received then repeat steps 2 to 4 above.

Cancelling a distress call before transmission

To cancel a distress call before it is transmitted follow the steps below:

1. Release the **DISTRESS** button before the count down timer completes.

When the button is released you will be returned to normal operation.

cancelling a distress call after transmission

A distress call can be cancelled after it has been transmitted.

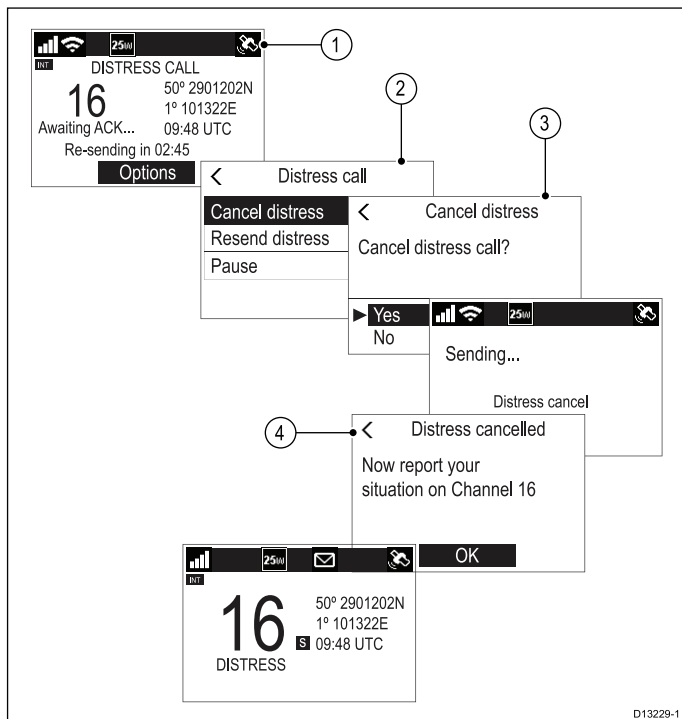

1. Select **Options**.
2. Select **Cancel distress**.
3. Select **Yes** to confirm cancellation.
4. Select **OK**.
5. Press and hold the **PTT** button and make a broadcast to all stations giving your vessel's name, call sign and MMSI number and cancel the false distress alert

Example: "All, Stations, All Stations, All Stations. This is <NAME>, <CALL SIGN>, <MMSI ID>, <POSITION>. Cancel my distress alert of <DATE>, <TIME>, <NAME>, <CALL SIGN>"

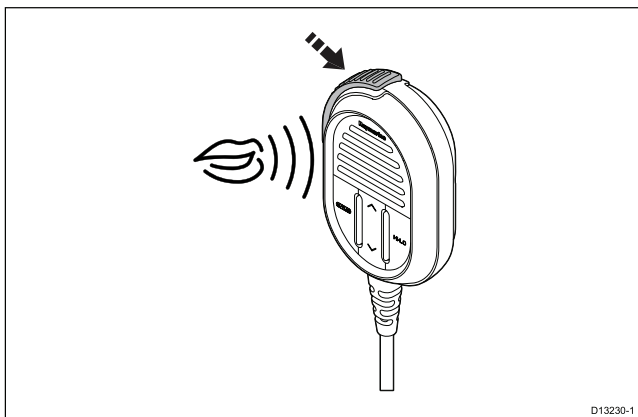

6. Repeat the broadcast described in step 5.

Receiving a distress call

It is expected that only a Coast Radio Station (CRS) will acknowledge DSC distress calls and will act as the coordinator for the rescue operation.

When a distress call is received an alarm is sounded at full volume and the LCD displays information relating to the distress.



If the **Auto channel change** function is enabled; 10 seconds after receipt of a distress call the radio will automatically re-tune to channel 16. Otherwise the user is prompted to change channel manually.

The details of the distress call are recorded in the distress log and the envelope icon will flash to let you know a message has been received. When connected to a **Raymarine®** multifunction display (MFD) the position data from the distress call can also be displayed in the Chart application.

When the received distress call is acknowledged by the CRS or by another station the radio will resume normal operation.

Ignoring a distress call

You can ignore a distress call by muting the alarm and cancelling the distress call screen.

If your radio is already tuned to the priority channel then the **Ignore** option will not be available.

With an incoming distress call displayed.

1. Select **Ignore** from the options displayed. Normal operation is resumed.

Acknowledging a distress call

Distress calls must only be acknowledged if the call continues without acknowledgement from a CRS, you are close enough to the distressed vessel to be of assistance and are prepared to relay the distress to a CRS by any means possible. Class D DSC radios are forbidden from automatically acknowledging distress calls. Acknowledgement must only be made by voice message on channel 16.

After receiving a distress call that has gone unanswered:

1. Switch to channel 16 to listen for the distress voice message.
2. Wait for the CRS to acknowledge the call.
3. If the distress call is not acknowledged by another station then acknowledge the call as follows:

MAYDAY

(MMSI of the vessel in distress)

Name of vessel in distress <repeated 3 times>

Call sign of the vessel in distress

This is <MMSI of your vessel>, <name of your vessel repeated 3 times> <call sign of your vessel>

RECEIVED MAYDAY

4. You **MUST** then notify the shore authorities by any means possible to relay the distress call.

Manually relaying a distress call

A distress relay should only be sent if: the person or vehicle in distress is unable to transmit the distress call itself, for example red flares sighted at night or the person or vehicle in distress is out of range of a CRS and you have already acknowledged the distress by voice message. You can also relay a received distress relay alert manually if it goes unanswered.

1. Switch to channel 16
2. Slowly and clearly speak the details of the distress:

MAYDAY RELAY, MAYDAY RELAY, MAYDAY RELAY

This is <MMSI of your vessel, name of your vessel repeated 3 times and your call sign>

Received the following MAYDAY from <MMSI of vessel in distress, name of vessel in distress, call sign of vessel in distress>

Message begins

Message received from vessel in distress or details of the distress

Message ends

OVER

Distress relays sent by other stations

When a Coast Station or another vessel, has received, and acknowledged a DSC distress alert it may transmit a distress alert relay to other vessels in the immediate area.

Distress relays sent from other stations can be received by the radio.

The radio cannot re-send a distress relay automatically. If required you can relay a distress relay message manually.

If a distress relay is sent specifically to the radio then it can be acknowledged, otherwise acknowledgement is not required.

Acknowledging a distress relay sent to your vessel

If a distress relay is specifically sent to your vessel this will be because the sender deems you to be in a position to assist in the rescue. The distress relay information is displayed onscreen.

When a distress relay is received:

1. Select **Show info** from the options to review the relevant details.
2. If the distress relay was sent individually to you, select **Accept** to send a distress relay acknowledgement.
3. Ensure the radio is tuned to channel 16.

Note: Distress relay calls can only be acknowledged automatically when sent individually to you.

7.3 Urgency calls

Making an urgency call

An urgency call should be used when there is danger to a vehicle or person that does not require immediate assistance. Urgency calls are transmitted to all stations.

From the **All ships call** menu: **Menu > DSC Calls > All ships call.**

1. Select **Urgency**.
2. Select the channel for subsequent communication.

The call is transmitted. Once the call has been successfully transmitted '**Sent**' is displayed onscreen and the channel is changed to the specified channel.

3. Press the **OK** button.
4. Press and hold the **PTT** button and speak the following message:

PAN PAN, PAN PAN, PAN PAN

ALL STATIONS, ALL STATIONS, ALL STATIONS

This is <MMSI of your vessel, name of your vessel repeated 3 times, call sign of your vessel>

Position <Your vessel's position>

Reason for call <State the reason for the call and include all information which will assist in the rescue.

OVER

Receiving an urgency call

When an urgency call is received:

1. Select **Show info** from the options to review relevant call details.
2. Select **Accept** at any time to accept the call.

If auto channel change is turned on then the channel will automatically change after 10 seconds.

The radio is re-tuned to the specified channel.
3. Listen for the urgency call message.

7.4 Safety calls

Making a safety call

Safety calls should be used when there is an important navigational warning or meteorological forecast/broadcast. Safety alerts can also be used for communications during search and rescue operations.

From the **All ships call** menu: **Menu > DSC Calls > All ships call**.

1. Select **Safety**.
2. Select the channel for subsequent communication.
The call is transmitted. Once the call has been successfully transmitted '**Sent**' is displayed onscreen and the channel is changed to the specified channel.
3. Press the **OK** button.
4. Press and hold the **PTT** button and speak the following message:

SECURITE, SECURITE, SECURITE

ALL STATIONS, ALL STATIONS, ALL STATIONS

This is <MMSI of your vessel, name of your vessel repeated 3 times, call sign of your vessel>

Position <Your vessel's position>

Reason for call <state the reason for the safety call>

OUT

Receiving a safety call

When a safety call is received:

1. Select **Show info** from the options to review relevant call details.
2. Select **Accept** at any time to accept the call.

If auto channel change is turned on then the channel will automatically change after 10 seconds.

The radio is re-tuned to the specified channel.

3. Listen for the safety call message.

7.5 Individual (routine) calls

Individual calls can be made to contacts saved in your phonebook or to any station by manually entering an MMSI number.

Note: When calling a coast station there is no need to select a channel for communication.

If a call cannot be accepted then a reason code is displayed.

No Reason	No reason given
Congestion	Congestion at maritime switching centre
Busy	Station Busy
Queue	Queue indication
Barred	Station barred
No operator	No operator available
Unavailable	Operator temporarily unavailable
Disable	Equipment disabled
Unable Ch	Unable to use proposed channel
Unable mode	Unable to use proposed mode

Making a routine DSC call

From the **Individual Call** menu: **Menu > DSC Calls > Individual Call**.

1. Select **Phonebook** to make a routine call to a contact saved in your Phonebook, or
2. Select **Recent Calls** to make a routine call to a contact that you have called recently, or
3. Select **Enter MMSI** to manually enter the MMSI number of the station you want to contact.
4. Select a contact or enter an MMSI manually and press the **OK** button.
5. Select the Channel you want to transmit the call on.

If the MMSI is a CSR then the radio will automatically tune to the correct Channel. The radio will wait for an acknowledgement to be received.

6. If an acknowledgement is received, press the **OK** button.
7. Press and hold the **PTT** button and speak your message.
8. Release the **PTT** button when you have completed your message.

Receiving an individual (routine) call

With an incoming individual call displayed:

1. Select **Show info** from the options to review relevant call details.
2. Select **Reply on Ch ##** at any time to accept the call.

If auto channel change is turned on then the channel will automatically change after 10 seconds.

The radio is re-tuned to the specified channel.

3. To reject the call, select **Reject**.

4. If you rejected the call, select a reason for the rejection from the list.

Confirmation of the acceptance or rejection of the call is displayed. If you have accepted the call then the radio will re-tune to the requested channel.

7.6 Group calls

Group calls can be made to groups of vessels sharing the same Group MMSI numbers.

Group calls are made by selecting a saved group contact from the **Phonebook** or by entering the Group MMSI number for the group you want to call.

Making a group call

From the **Group Call** menu: **Menu > DSC Calls > Group Call**.

1. Select **Phonebook** to make a call to a group saved in your Phonebook, or
2. Select **Recent Calls** to make a call to a group that you have called recently, or
3. Select **Enter MMSI** to manually enter the MMSI number of the group you want to contact.
4. Select a group or enter an MMSI manually and press the **OK** button.
5. Select the Channel you want to transmit the call on.

The radio will wait for an acknowledgement to be received.

6. If an acknowledgement is received, press the **OK** button.
7. Press and hold the **PTT** button and speak your message.
8. Release the **PTT** button when you have completed your message.

Receiving a group call

Note: To receive a call made to a Group, the Group's MMSI number must be saved in your phonebook.

With an incoming group call displayed:

1. Select **Show info** from the options to review relevant call details.
2. Select **Reply on Ch ##** at any time to accept the call.

If auto channel change is turned on then the channel will automatically change after 10 seconds.

The radio is re-tuned to the specified channel.

3. To reject the call, select **Reject**.
4. If you rejected the call, select a reason for the rejection from the list.

Confirmation of the acceptance or rejection of the call is displayed. If you have accepted the call then the radio will re-tune to the requested channel.

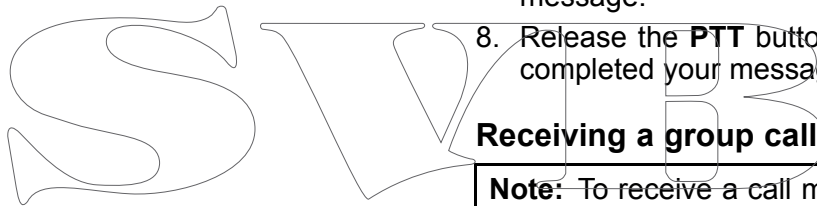

7.7 Position requests

The radio can request position information from any station capable of responding to the request.

Position requests can be sent to any contact stored in the **Phonebook** or by manually inputting the station's MMSI number.

When connected to a **Raymarine**® multifunction display the position data from the request can also be display in the Chart application.

Making a position request

You can request the position of another station.

From the **Position Request** menu: **Menu > DSC Calls > Position Request**.

1. Select **Phonebook** to request the position of a contact saved in your Phonebook, or
2. Select **Recent Calls** to request the position of a contact that you have called recently, or
3. Select **Enter MMSI** to manually enter the MMSI number of the station that you want to request the position of.
4. Select a contact or enter an MMSI manually and press the **OK** button.

The position request is sent. When a response is received the position of the contact is displayed.

Responding to a position request

With a Position request displayed:

1. Select **Send position** to respond with your current location, or
2. Select **Cancel** to ignore the request.
3. If the position reply is set to manual then select **SEND** to send the position report.
4. Select **OK** to resume normal operation.

If the **Position requests** setting, found in the **GPS set-up** menu is set to **Auto accept** then the response is sent automatically.

Setting automatic response to position requests

You can configure your radio to respond to incoming position requests automatically.

From the **DSC set-up** menu: **Menu > Set-up > DSC set-up**

1. Select **Position requests** to switch between Manual accept (default) and Auto accept.

7.8 Phonebook

The phonebook can be used to save up to 100 contacts.

You can add, edit and delete contacts stored in the phonebook.

Adding a phonebook entry

You can save contacts in the phonebook by entering their MMSI and assigning a name to the contact.

From the **DSC Calls** menu: **Menu > DSC Calls**.

1. Select **Phonebook**.
2. Select **Add new**.
3. Select the type of contact.
 - Vessel
 - Group
 - Coast station
4. Use the **Rotary knob** to cycle through the available numbers and press **OK** to confirm and move to the next digit.
5. Press the **OK** button to confirm the MMSI.
6. Use the **Rotary knob** to cycle through the available characters and press **OK** to confirm and move to the next character.

The maximum length for contact names is 10 characters.

7. If the Contact name is less than 10 characters, press and hold the **OK** button and select **Save**.
8. Press the **Back** button at any time to edit characters you have already entered.
9. Press and hold the **OK** button and select **Move cursor** to edit an existing character.
10. When complete press the **OK** button to return to the Phonebook.

Editing a phonebook entry

From the **DSC Calls** menu: **Menu > DSC Calls**.

1. Select **Phonebook**.
2. Select the contact you want to edit.
3. Select **Edit name** or **Edit MMSI**
The contact's MMSI or name is displayed.
4. Use the **Rotary knob** to change a character.
5. Press the **OK** button to confirm each character and move to the next.
6. When you have completed your changes press the **OK** button again to save the changes.

Deleting a phonebook entry

From the **DSC Calls** menu: **Menu > DSC Calls**.

1. Select **Phonebook**.
2. Select the contact you want to edit.
3. Select **Delete**.
4. Select **Yes**.

The contact is deleted.

7.9 Call logs

All DSC calls are logged.

The following call types are recorded in call logs:

- distress
- distress relay
- distress acknowledgements
- sent position requests
- received position requests
- group calls
- all ship calls
- individual routine calls

The details below are recorded for each call:

- MMSI number(s) (If a call is relayed up to 3 MMSI numbers can be recorded.)
- type of call
- date and time of call
- latitude and longitude (if sent with the call)
- nature of distress (specified distress calls only)

If the call was received from a contact in the phonebook then the contact name is displayed, otherwise the MMSI number is displayed.

Accessing the call logs

Follow the steps below to access the call logs.

From the **DSC Calls** menu: **Menu > DSC Calls**.

1. Select **Call logs**.
2. Select the log you want to view:
 - Unread
 - Distress calls
 - Non-distress calls
 - Outgoing calls
 - Position log
3. Select a call and press the **OK** button to view details.
4. Select **Options** to view available options.
 - **Call Back** — return a received call.
 - **Resend** — only available in the outgoing call log.
 - **Call** — available in the position log.
 - **Send position** — available in the position log.
 - **Request position** — available for individual and distress calls.
 - **Save to Phonebook** — available for received and outgoing calls to new contacts.
 - **Send ACK** — available for unacknowledged individual received calls.
 - **Delete** — deletes the log entry.

7.10 Test calls

A Test Call feature is available for the purposes of testing your DSC VHF radio for correct operation.

There are 2 types of test call:

- Test call to the US Coast Guard automated response test call service (MMSI: **003669999**). This type of test call will receive an automated response (acknowledgement).
- Test call to another vessel that has a radio that supports the test call feature. Your radio will automatically acknowledge test calls received from other radios.

For radios that do NOT support the test call feature, correct radio operation can be tested by making an individual call on channel 70 to another DSC VHF radio.

Raymarine recommends that once you've successfully placed a test call you add the test call MMSI to your radio's phonebook for easy retrieval for future test calls. For information on how to add an MMSI to your radio's phonebook, refer to the radio's user documentation.

Note: Individual calls (that is, NOT a test call) to the US Coast Guard 003669999 MMSI will NOT receive an automated response.

Note: The US Coast Guard automated response test call service is only available in the United States and its coastal waters.

Making a test call

From the **Test call** menu: **Menu > DSC ~Calls > Test call**.

1. Select **Phonebook** to make a test call to a contact saved in your Phonebook, or
2. Select **Recent Calls** to make a test call to a contact that you have called recently, or
3. Select **Enter MMSI** to manually enter the MMSI number of the station you want to send a test call.
4. Select a contact or enter an MMSI manually and press the **OK** button.
The test call is sent.
5. If you called the US Coast Guard automated response test call MMSI (003669999), wait for an acknowledgement. If you made a test call to another vessel with a test call capable radio, your radio will wait for a response.
When an acknowledgement is received, an audible alarm is sounded and the message (envelope) icon is displayed.

Receiving a test call

Your radio will automatically acknowledge received test calls from other stations

When a test call is received a notification is displayed to alert you that a test call has been received and automatically acknowledged.

7.11 DSC set-up menu options

The **DSC set-up** menu options can be accessed from the following menus:

- **Menu > DSC Calls > DSC set-up**
- **Menu > Set-up > DSC set-up**

Menu item	Description	Options
MMSI	To enable the DSC functions on your radio you must enter your unique MMSI number.	
Auto channel change	When automatic channel change is turned on the radio will automatically re-tune after 10 seconds to the requested channel when DSC calls are received.	<ul style="list-style-type: none">• On (default)• Off
Position requests	With Position requests set to Auto accept the radio will automatically send out position details when a position request is received.	<ul style="list-style-type: none">• Auto accept (default)• Manual accept

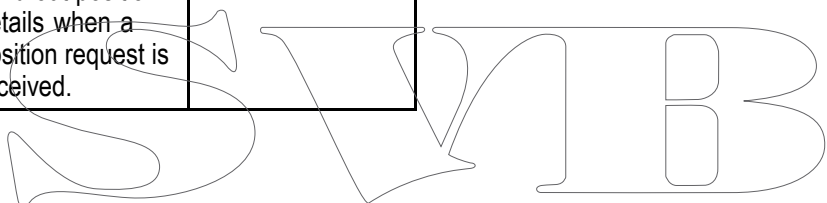

Chapter 8: VHF operations

Chapter contents

- 8.1 Watch modes on page 68
- 8.2 Scan Mode on page 68
- 8.3 Priority channels on page 69
- 8.4 Sensitivity on page 69
- 8.5 Private channels on page 70
- 8.6 Automatic Transmitter Identification System (ATIS) and Marcom-C mode on page 70
- 8.7 AIS — **Ray70** on page 71
- 8.8 Set-up menu options on page 72

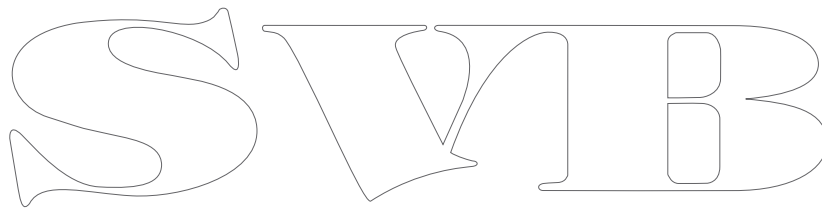

8.1 Watch modes

Watch mode monitors priority channels and the currently selected channel.

There are 2 types of watch mode; **Dual watch** and **Triple watch** or **Tri watch**.

- **Dual watch** — This mode monitors priority channel 16 and the currently selected channel.
- **Triple watch** or **Tri watch** This mode monitors priority channel 16, the second priority channel (Channel 9 (default)) and the currently selected channel. The second priority channel can also be set to a user defined channel.

When the radio detects a transmission, Watch mode is suspended until the transmission ends; watch mode will then recommence.

Using watch modes

From the **Watch Mode** menu: **Menu > Watch Mode**.

1. Select **Dual Watch** or **Triple Watch** as required.
The radio is now in Watch mode.
2. Select **2nd priority channel** to select a different second priority channel for **Triple Watch**.
3. During Watch mode, press the **Back** button at any time to end the Watch mode and resume normal operation.

8.2 Scan Mode

Scan mode enables automatic searching for channels that are currently broadcasting.

Scan mode will search through available channels and stop when it finds a channel that is currently broadcasting. If the broadcast stops or is lost for more than 5 seconds then the scan will resume.

Channels can be temporarily removed from an active scan, and the direction of scan can also be changed. When the scan reaches the last channel in the band the scan cycle is repeated.

The following scans options are available:

- **All Channels** — All channels in the frequency band the radio is set to are scanned in sequence.
- **All Channels + 16** — All channels in the frequency band the radio is set to are scanned, after each channel is scanned priority channel 16 is scanned.
- **Saved Channels** — Only channels saved to the radio's memory are scanned in sequence.
- **Saved Channels + 16** — Only channels saved to the radio's memory are scanned, after each channel is scanned priority channel 16 is scanned.

Note: If the weather alert function is activated, the weather alert channel is included in the scan.

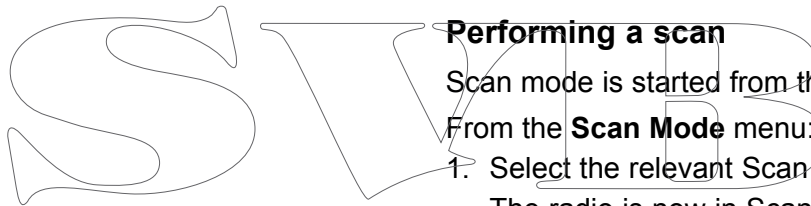

Performing a scan

Scan mode is started from the main menu.

From the **Scan Mode** menu: **Menu > Scan Mode**.

1. Select the relevant Scan mode.
The radio is now in Scan mode.
2. Select **Edit Saved Channels** to select the channels that will be scanned when performing a Saved channel scan.
3. During Scan mode, press the **Back** button at any time to end the Scan mode and resume normal operation.

8.3 Priority channels

Channel 16 is the dedicated priority channel.

The default secondary priority channel is channel 09. If your frequency band is set to **INT** (international) then the second priority channel can be changed.

Switching between priority channels

1. Press the **16 / +** button to switch between priority channels.

Setting a second priority channel

You can select which channel you want to use as the second priority channel.

From the **Channel set-up** menu: **Menu > Set-up > Channel set-up**.

1. Select **2nd priority channel**.
2. Select the channel that you want to assign as the second priority channel.

8.4 Sensitivity

The sensitivity level of the radio can be set to Local mode or Distant mode.

Local mode decreases the receiver sensitivity in high traffic areas to reduce unwanted reception. When in Local mode the 'Loc' icon is displayed in the status bar.

Distant mode sets the receiver sensitivity to full.

Switching sensitivity modes

You can switch between Local and Distant modes at any time.

From the **Set-up** menu: **Menu > Set-up**.

1. Select **Sensitivity**.
Selecting Sensitivity will switch between Local mode and Distant mode (default).

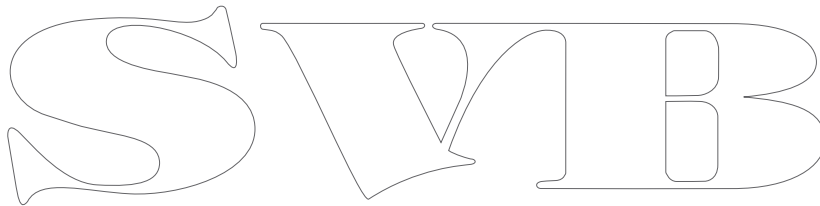

8.5 Private channels

The radio may be able to receive additional Private channels depending on the country it is used in and whether the appropriate licenses are held.

The following Private channel sets can be selected:

- None
- Belgium
- Denmark (pleasure)
- Denmark (fishing)
- Finland (pleasure)
- Finland (fishing)
- Holland (Netherlands)
- Norway (pleasure)
- Norway (fishing)
- Sweden (pleasure)
- Sweden (fishing)
- UK

Selecting a private channel set

You can select the set of private channels you want to use.

From the **Channel set-up** menu: **Menu > Set-up > Channel set-up**.

1. Select **Private channels**.

The list of private channel sets is displayed:

2. Select the required private channel set.

8.6 Automatic Transmitter Identification System (ATIS) and Marcom-C mode

ATIS is a European system used on some inland waterways.

VHF radios operating in an ATIS region must be programmed with a unique ATIS number; this can be obtained from the relevant licensing authority. The ATIS number is attached as a digital signal at the end of each transmission and identifies you to the relevant authorities who monitor the system.

When operating in ATIS mode, some of the products features are not available:

- Use of DSC functions is not permitted in ATIS regions.
- Watch modes are not permitted in ATIS regions.
- Channel scanning is not permitted in ATIS regions.
- ATIS regulations restrict the transmit power to 1 watt for the following channels: 6, 8, 10, 11, 12, 13, 14, 71, 72, 74 and 77.

You can enable or disable ATIS using the menus (except on Marcom-C configured units).

Marcom-C mode

Marcom-C mode is a restricted radio configuration for VHF operators with a Marcom-C license. This is applicable to radios operated exclusively in European inland waterways using the ATIS system.

A Marcom-C VHF radio has the ATIS permanently enabled. You will not be able to disable ATIS operation. Marcom-C operation is set by the dealer at point of sale. If you wish to enable or disable Marcom-C mode, you must contact your Raymarine dealer.

For further information please contact Raymarine technical support.

Enabling and disabling ATIS mode

ATIS is a European system used on some inland waterways. ATIS must be enabled and a unique ATIS ID entered in order to use ATIS mode.

From the Main menu.

1. Select **Set-up**.
2. Select **ATIS set-up**.
3. Select **ATIS**.
4. Select **On** to enable ATIS mode or **Off** to disable ATIS mode.

With ATIS mode enabled the radio's region will be fixed to the INT (international) frequency band and the following functions are disabled:

- DSC functions
- Watch Mode
- Scan Mode
- High/low power is restricted on certain channels

Once ATIS has been enabled an ATIS ID must be entered.

8.7 AIS — Ray70

The **Ray70** has a built in AIS receiver.

With the built-in AIS receiver switched on AIS information can be sent to a connected **Raymarine® MFD** using either **NMEA 0183** or **SeaTalk^{ng}®**.

Note: If using the built-in AIS receiver and outputting over **NMEA 0183**, ensure that the baud rate is set to **0183 High speed: Menu > Set-up > Network output** .

Switching AIS on and off

From the **Set-up** menu: **Menu > Set-up**.

1. Select **AIS**.
Selecting AIS will switch the internal AIS receiver On and Off.

The image shows the letters 'SWIB' in a large, stylized, outlined font. The letters are white with a black outline, set against a plain white background. The font is a decorative, slightly gothic or serif style.

8.8 Set-up menu options

The **Set-up** menu options can be accessed from the menu.

Menu	Description	Options
Display set-up	Provides access to the display settings menu	<ul style="list-style-type: none"> • Backlight • Shared brightness • Contrast • Homescreen display
Language	Enables selection of user interface language.	<ul style="list-style-type: none"> • English (default) — English • Español — Spanish • Français — French • Deutsch — German • Italiano — Italian
Units	Provides access to units of measure related settings	<ul style="list-style-type: none"> • Time format • Time offset • Bearing mode • Speed unit
Power output	Enables you to switch the Power output of the radio.	<ul style="list-style-type: none"> • Distant (default) • Local
Sensitivity	Enables you to switch the Sensitivity of the radio.	<ul style="list-style-type: none"> • Low • High (default)
Noise cancelling (Tx)	<p>Enables you to switch the transmission noise cancellation feature On and Off.</p> <p>Note: Only available on Ray60 and Ray70.</p>	<ul style="list-style-type: none"> • On (default) • Off
Key Beep	Enables adjustment of the beep heard when pressing buttons.	<ul style="list-style-type: none"> • Off • Quiet (default) • Loud
Channel set-up	Provides access to the Channel set-up menu.	<ul style="list-style-type: none"> • Channel name • 2nd priority channel • Private channels • Frequency band
GPS set-up	Provides access to the GPS set-up menu.	<ul style="list-style-type: none"> • Internal GPS • Homescreen display • Bearing mode • Position requests • Set manual position
DSC set-up	Provides access to the DSC set-up menu.	<ul style="list-style-type: none"> • MMSI • Auto channel change • Position requests
AIS	Enables you to switch the Ray70's internal AIS receiver on and off.	<ul style="list-style-type: none"> • Off (default) • On
Network output	Enables you to select the network to be used to output data.	<ul style="list-style-type: none"> • NMEA 2000 • 0183 High speed • 0183 Std speed

Menu	Description	Options
ATIS set-up	Enables you to switch ATIS mode on and off and enter your ATIS ID.	<ul style="list-style-type: none"> • ATIS • ATIS ID
Maintenance	Enables you to view system details and functions that may be required during maintenance and troubleshooting.	<ul style="list-style-type: none"> • About this unit • System reset • System test

SVIB

SWIB

Chapter 9: Hailer, Fog horn, and Intercom

Chapter contents

- 9.1 Hailer Fog Intercom menu on page 76
- 9.2 Loud Hailer — **Ray70** on page 76
- 9.3 Fog horn on page 77
- 9.4 Intercom — **Ray60** and **Ray70** on page 77

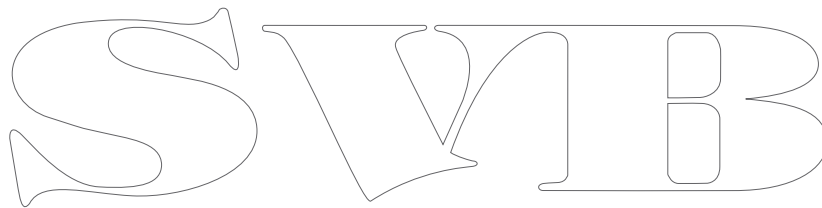

9.1 Hailer Fog Intercom menu

The menu options available are determined by the device connected to your radio.

Menu name	Connected devices
Hail/Fog/Int	Loud hailer and second station connected.
Hailer/Fog	Loud hailer connected, no second station
Intercom	Second station connected, no loud hailer

Note: For simplicity the procedures in this section all refer to the **Hail/Fog/Int** menu.

9.2 Loud Hailer — Ray70

The **Ray70** can be connected to a Loud hailer.

In hailer mode anything spoken into the handset is amplified and broadcast from the hailer, the message is not transmitted over VHF channels.

When the hailer is active VHF calls cannot be sent or received.

Using the hailer

From the **Hail/Fog/Int** menu: **Menu > Hail/Fog/Int.**

1. Select **Hailer**.
Hailer mode is now active
2. Press and hold the **PTT** button.
3. Speak your message.
4. Release the **PTT** button.
5. Press the **Back** button to exit Hailer mode.
6. The hailer listening volume can be adjusted at any time in Listening mode using the **Volume Control**.
7. The hailer talking volume can be adjusted at any time, with the **PTT** button pressed using the **Volume Control**.

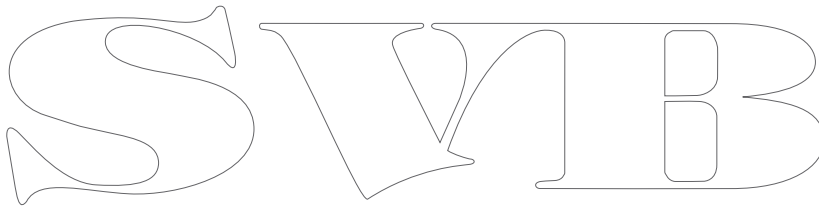

9.3 Fog horn

The fog horn function requires an optional loud hailer to be connected.

The fog horn function can be set to manual or to a predefined automatic mode

The predefined automatic modes consist of a sequence of tones which are then repeated.

Fog mode	Description	Pattern
Underway	Vessel underway	1 long tone
Underway/Stopped	Vessel not underway	2 long tones
Sailing/Fishing	sailing vessel or any vessel fishing but not trolling	1 long tone and 2 short tones
Restrict/Tow	Restricted in ability to maneuver or towing another vessel	1 long tone and 2 short tones
Under tow	This vessel is being towed	1 long tone and 3 short tones
Pilot vessel	This vessel is a pilot vessel	4 short tones
At anchor	Vessel is at anchor	12 consecutive rings
Aground	Vessel is aground	3 short rings, 12 consecutive rings, 3 short rings

In manual mode a continuous tone is sounded for as long as the **PTT** button is pressed.

Note: VHF calls can only be made between fog horn patterns.

Using the fog horn in manual mode

From the **Hail/Fog/Int** menu: **Menu > Hail/Fog/Int**.

1. Select **Fog horn**.
2. Select **Manual mode**.
3. Press and hold the **PTT** button to sound a continuous fog horn tone.
4. Press the **Back** button to exit Fog horn mode.

Using automatic fog horn modes

From the **Hail/Fog/Int** menu: **Menu > Hail/Fog/Int**.

1. Select **Fog horn**.
2. Select **Automatic mode**.
3. Select an automatic pattern.
The selected pattern will play and repeat until interrupted.
4. Select **Stop fog horn** to exit the automatic fog horn mode, or
5. Select **Change pattern** to select a different fog horn pattern.

9.4 Intercom — Ray60 and Ray70

The Intercom function is available when a second station is connected to your radio.

The intercom function allows voice communication between the second (handset) station and the primary station. A call can be initiated from either station.

Using the intercom

From the **Hail/Fog/Int** menu: **Menu > Hail/Fog/Int**.

1. Select **Intercom**.
The other station will ring.
2. Wait for the handset station to acknowledge the call.
3. Press and hold the **PTT** button and speak your message.

Responding to the intercom

1. Press the **PTT** button and acknowledge the call and to respond to subsequent voice messages.



SWIB

Chapter 10: Maintenance

Chapter contents

- [10.1 Maintenance on page 80](#)
- [10.2 Routine checks on page 80](#)
- [10.3 Product cleaning on page 81](#)
- [10.4 Unit cleaning instructions on page 81](#)

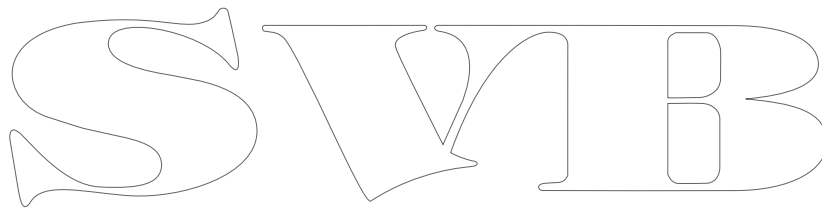
The logo for SWIB is rendered in a large, outlined, serif font. The letters are white with a thin black outline. The 'S' is a classic serif with a small tail. The 'V' is a simple, slightly pointed serif. The 'I' is a simple vertical bar with a small serif at the top. The 'B' is a classic serif with a large, rounded bowl and a small tail.

10.1 Maintenance

The Ray260 has no user serviceable parts or adjustments. Never remove the cover or attempt to service the product, doing so may invalidate your product warranty.

The following preventive measures should be followed:

- Although the product is waterproof, keep the unit as dry as possible.
- If you remove a handset connection ensure the dust cap is fitted to the connector.

10.2 Routine checks

The following periodic checks should be made:

- Examine cables for signs of damage, such as chafing, cuts or nicks.
- Check that the cable connectors are firmly attached and that their locking mechanisms are properly engaged.

Note: Cable checks should be carried out with the power supply switched off.

SVIB

10.3 Product cleaning

Best cleaning practices.

When cleaning products:

- If your product includes a display screen, do NOT wipe the screen with a dry cloth, as this could scratch the screen coating.
- Do NOT use abrasive, or acid or ammonia based products.
- Do NOT use a jet wash.

10.4 Unit cleaning instructions

The unit does not require regular cleaning. However, if you find it necessary to clean the unit, please follow the steps below:

1. Ensure power is switched off.
2. Wipe unit clean with a damp cloth.
3. If necessary, use a mild detergent solution to remove grease marks.

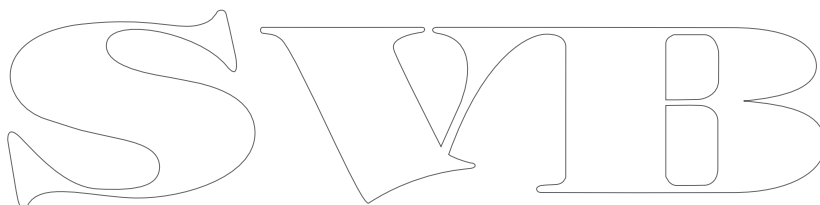
The image shows a stylized outline logo for the brand 'SWIB'. The letters are rendered in a decorative, serif font with a double-line outline effect. The 'S' is on the left, followed by 'W', 'I', and 'B' on the right. The 'W' and 'I' are connected, and the 'B' has a distinct shape with a vertical bar.

SWIB

Chapter 11: Troubleshooting

Chapter contents

- [11.1 Troubleshooting on page 84](#)
- [11.2 Performing a system reset on page 84](#)
- [11.3 System test on page 85](#)
- [11.4 Power up troubleshooting on page 86](#)
- [11.5 VHF Radio troubleshooting on page 87](#)
- [11.6 GPS troubleshooting on page 88](#)

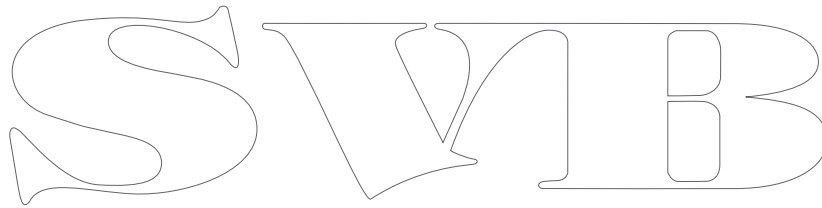

11.1 Troubleshooting

The troubleshooting information provides possible causes and corrective action required for common problems associated with marine electronics installations.

All Raymarine products are, prior to packing and shipping, subjected to comprehensive test and quality assurance programs. However, if you experience problems with the operation of your product this section will help you to diagnose and correct problems in order to restore normal operation.

If after referring to this section you are still having problems with your unit, please contact Raymarine Technical Support for further advice.

11.2 Performing a system reset

Note: Performing a reset will not reset MMSI and ATIS ID number.

From the Maintenance menu: **Menu > Set-up > Maintenance.**

1. Select **System reset.**
2. Select **Yes.**

The system is now reset to factory defaults.

Note: Performing the reset will delete all contacts in your phonebook and reset all user options.

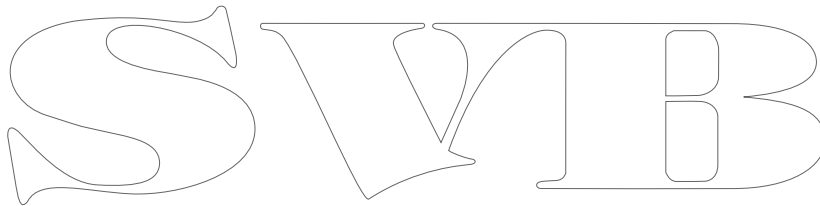
The image shows a large, stylized outline logo for 'SWIB'. The letters are interconnected and have a decorative, calligraphic feel. The 'S' is on the left, followed by 'W', 'I', and 'B' on the right. The entire logo is rendered in a simple black outline.

11.3 System test

The system test menu can be used to show the status of the system and connected devices.

The System test menu show the status of the following system components and connected devices:

- GPS
- DSC
- Battery
- Hailer
- Remote handset
- **OK** is displayed next to each item that is either connected or enabled
- **No** is displayed next to items that are either not connected or disabled.

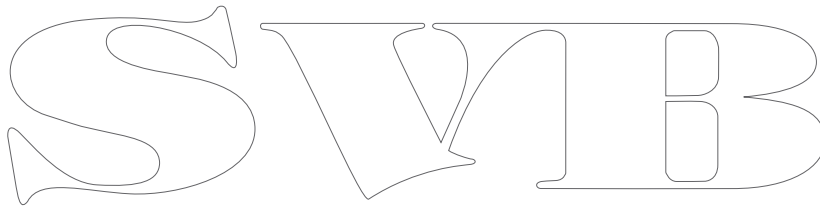
The image shows the letters 'SVIB' in a large, stylized, outlined font. The letters are white with a black outline, set against a plain white background. The 'S' is a simple, rounded shape. The 'V' is a simple, pointed shape. The 'I' is a simple, vertical bar. The 'B' is a simple, rounded shape with a vertical bar in the middle.

11.4 Power up troubleshooting

Problems at power up and their possible causes and solutions are described here.

Product does not turn on or keeps turning off

Possible causes	Possible solutions
Blown fuse / tripped breaker	<ol style="list-style-type: none"> 1. Check condition of relevant fuses and breakers and connections, replace if necessary (Refer to Chapter 13 Technical specification for fuse ratings.) 2. If fuse keeps blowing check for cable damage, broken connector pins or incorrect wiring.
Poor / damaged / insecure power supply cable / connections	<ol style="list-style-type: none"> 1. Check that the power cable connector is fully inserted into the unit and locked in position. 2. Check the power supply cable and connectors for signs of damage or corrosion, replace if necessary. 3. With the unit turned on, try flexing the power cable near to the display connector to see if this causes the unit to re-boot/loose power, replace if necessary. 4. Check the vessel's battery voltage, the condition of the battery terminals and power supply cables, ensuring connections are secure, clean and free from corrosion, replace if necessary. 5. With the product under load, using a multi-meter, check for high voltage drop across all connectors/fuses etc, replace if necessary.
Incorrect power connection	The power supply may be wired incorrectly, ensure the installation instructions have been followed. (Refer to Chapter 4 Cables and connections for cable and connection requirements.)
Power source insufficient	With the product under load, using a multi-meter, check the power supply voltage as close to the unit as possible to establish actual voltage when the current is flowing. (Refer to Chapter 13 Technical specification for power supply requirements.)

Product will not boot up (re-boot loop)

Possible causes	Possible solutions
Power supply and connection	See possible solutions from 'Products does not turn on or keeps turning off' above.
Software corruption	<ol style="list-style-type: none"> 1. In the unlikely event that the products software has become corrupted please try re-flashing the latest software from the Raymarine website.

11.5 VHF Radio troubleshooting

Problems with your VHF radio and their possible causes and solutions are described below:

DSC functions are not available / working

MMSI number not programmed.	Programme your MMSI number.
Radio is set to ATIS or Marcom-C mode.	Use of DSC is not permitted when in ATIS or Marcom-C mode. You will be unable to make DSC distress and other types of digital selective call. If you are not in an ATIS region switch off ATIS mode: Menu > Set-up > ATIS set-up > ATIS.
Sensitivity set to Local.	With the sensitivity set to Local your reception will be limited Set Sensitivity to Distant: Menu > Set-up > Sensitivity.

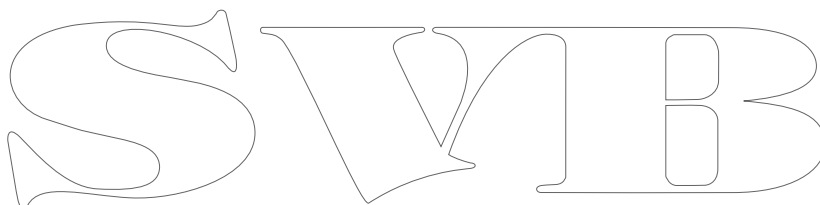
A large, stylized outline logo consisting of the letters 'S', 'V', 'I', and 'B' in a decorative, serif font. The letters are interconnected and have a thin, hollow appearance.

11.6 GPS troubleshooting

Problems with the GPS/GNSS and their possible causes and solutions are described below.

Before troubleshooting GPS problems ensure your product has the latest software, by checking the Software Updates page on the Raymarine website www.raymarine.com.

No GPS fix

Possible causes	Possible solutions
GPS switched off	Ensure you external or internal GPS/GNSS receiver is switched on.
Geographic location or prevailing conditions preventing satellite fix.	Check periodically to see if a fix is obtained in better conditions or another geographic location.
Location of product	For optimum performance the unit should be mounted above decks and not be in close proximity to any structural bulkheads or other electrical equipment or cables which may cause interference. Refer to Chapter 3 Planning the installation for details on product location requirements

No GPS data

Possible causes	Possible solutions
Internal GPS is switched off	Ensure you external or internal GPS/GNSS receiver is switched on.
Wrong Network output selected	Ensure the correct network type and speed is selected in the Network output menu: Menu > Set-up > Network output .
Poor / damaged / insecure cable / connection	<ol style="list-style-type: none"> 1. Check that the connectors are fully inserted into the unit and locked in position. 2. Check the cables and connectors for signs of damage or corrosion, replace if necessary. 3. Check the vessel's battery voltage, the condition of the battery terminals and power supply cables, ensuring connections are secure, clean and free from corrosion, replace if necessary. 4. With the product under load, using a multi-meter, check for high voltage drop across all connectors/fuses etc, replace if necessary.

Note: The **Ray70's** internal GPS does not output data on the network.

Chapter 12: Technical support

Chapter contents

- [12.1 Raymarine customer support on page 90](#)
- [12.2 Viewing product information on page 90](#)
- [12.3 Learning resources on page 91](#)

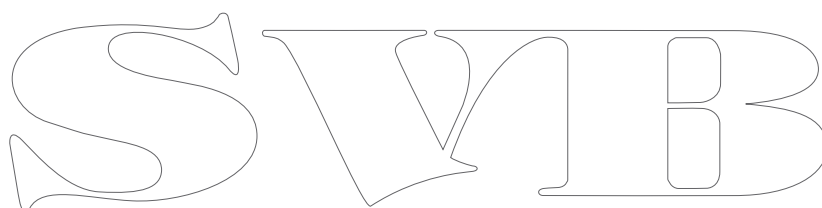

12.1 Raymarine customer support

Raymarine provides a comprehensive customer support service. You can contact customer support through the Raymarine website, telephone and e-mail. If you are unable to resolve a problem, please use any of these facilities to obtain additional help.

Web support

Please visit the customer support area of our website at:

www.raymarine.com

This contains Frequently Asked Questions, servicing information, e-mail access to the Raymarine Technical Support Department and details of worldwide Raymarine agents.

Telephone and e-mail support

In the USA:

- **Tel:** +1 603 324 7900
- **Toll Free:** +1 800 539 5539
- **E-mail:** support@raymarine.com

In the UK, Europe, and the Middle East:

- **Tel:** +44 (0)13 2924 6777
- **E-mail:** ukproduct.support@raymarine.com

In Southeast Asia and Australia:

- **Tel:** +61 (0)29479 4800
- **E-mail:** aus.support@raymarine.com

Product information

If you need to request service, please have the following information to hand:

- Product name.
- Product identity.
- Serial number.
- Software application version.
- System diagrams.

You can obtain this product information using the menus within your product.

12.2 Viewing product information

Product information can be found on the Startup screen.

1. Power up the radio.

The startup screen is displayed which shows the model and software version of the product.

Alternatively product information can also be displayed by selecting **About this unit** from the **Maintenance** menu: **Menu > Set-up > Maintenance**.

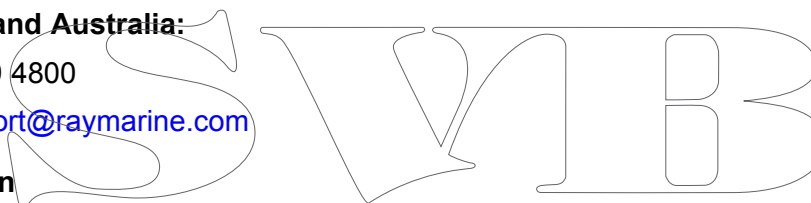

12.3 Learning resources

Raymarine has produced a range of learning resources to help you get the most out of your products.

Video tutorials

	<p>Raymarine official channel on YouTube:</p> <ul style="list-style-type: none">• http://www.youtube.com/user/RaymarineInc
	<p>Video Gallery:</p> <ul style="list-style-type: none">• http://www.raymarine.co.uk/view/?id=2679
	<p>Product Support videos:</p> <ul style="list-style-type: none">• http://www.raymarine.co.uk/view/?id=4952

Note:

- Viewing the videos requires a device with an Internet connection.
- Some videos are only available in English.

Training courses

Raymarine regularly runs a range of in-depth training courses to help you make the most of your products. Visit the Training section of the Raymarine website for more information:

- <http://www.raymarine.co.uk/view/?id=2372>

FAQs and Knowledge Base

Raymarine has produced an extensive set of FAQs and a Knowledge Base to help you find more information and troubleshoot any issues.

- <http://www.raymarine.co.uk/knowledgebase/>

Technical support forum

You can use the Technical support forum to ask a technical question about a Raymarine product or to find out how other customers are using their Raymarine equipment. The resource is regularly updated with contributions from Raymarine customers and staff:

- <http://raymarine.ning.com/>

SWIB

Chapter 13: Technical specification

Chapter contents

- 13.1 Technical specification — **Ray50** on page 94
- 13.2 Technical specification — **Ray60** on page 95
- 13.3 Technical specification — **Ray70** on page 96
- 13.4 Radio usage on page 97

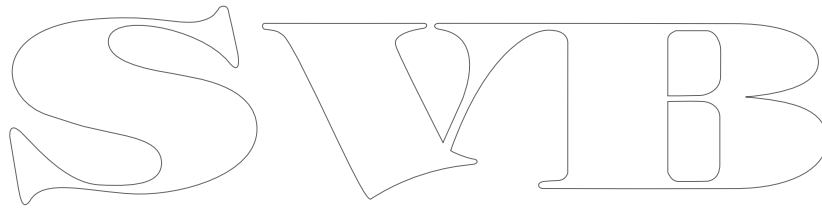
The image shows the letters 'SWIB' in a large, stylized, outlined font. The letters are white with a thin black outline. The 'S' is a simple, rounded shape. The 'W' is composed of two 'V' shapes joined at the top. The 'I' is a simple vertical bar with a small horizontal bar at the top. The 'B' is a simple, rounded shape with a vertical bar in the middle.

13.1 Technical specification — Ray50

Environmental specification

Operating temperature	-20°C (-4°F) to +60°C (140°F)
Storage temperature	-25°C (-13°F) to +70°C (158°F)
Relative humidity	95%
Water proofing	IPX6 & IPX7
Connections	<ul style="list-style-type: none"> • 1 x NMEA 0183 • 1 x SeaTalk^{ng}® / NMEA 2000 • 1 x Audio (RCA)

Power specification

Nominal supply voltage	12 V dc (Reverse polarity and over voltage protection)
Operating voltage range	9 V dc to 16 V dc
Current consumption	<ul style="list-style-type: none"> • Less than 6 A at high power (13.6 V) • Standby: 600 mA • Receive: 2 A

Transmitter

Channels	All available US, International and Canadian VHF marine bands
Frequency Range	156.000 MHz to 157.425 MHz 155.500 MHz to 161.425 MHz (Private channels)
Frequency stability	+/- 1.5 ppm
Channel Spacing	12.5 kHz
Power Output	<ul style="list-style-type: none"> • Low power setting — 1 W • High power setting — 25 W
Spurious emissions	Better than -36 dBm at 25 W (Less than 0.25 µW)
Maximum deviation	+/- 5 KHz
Antenna impedance	50 Ohms (typical)

Receiver

Receiver type	Double conversion super heterodyne
Channels	All available US, International and Canadian VHF marine bands
Frequency range	156.050 MHz to 163.275 MHz / 155.500 MHz to 161.425 MHz (Private channels)
Sensitivity	Better than 1 microvolt EMF @ 20dB SINAD
Squelch sensitivity	Less than -2 dBµ EMF
Hum and noise	Better than -40 dB
Audio distortion	Less than 10%

Receiver sensitivity	<ul style="list-style-type: none"> • Distance — 119dBm (0.25uV) @ 12dB SINAD (typical) • Local — 110dBm (0.7uV) @ 12dB SINAD (typical)
Adjacent channel selectivity	More than 70 dB
Spurious response rejection	More than 70 dB
Inter modulation rejection	More than 68 dB

Speakers

Base station speaker power output	2.5 W (8 Ω)
Fistmic speaker power	1 W (16 Ω)
External speaker power	5 W (4 Ω) / 2.5 W (8 Ω)

13.2 Technical specification — Ray60

Environmental specification

Operating temperature	-20°C (-4°F) to +60°C (140°F)
Storage temperature	-25°C (-13°F) to +70°C (158°F)
Relative humidity	95%
Water proofing	IPX6 & IPX7
Connections	<ul style="list-style-type: none"> • 1 x NMEA 0183 • 1 x SeaTalk^{ng}® / NMEA 2000 • 1 x Front Fismic connection • 1 x Rear connection for 2nd station • 1 x Audio (RCA)

Power specification

Nominal supply voltage	12 V dc (Reverse polarity and over voltage protection)
Operating voltage range	9 V dc to 16 V dc
Current consumption	<ul style="list-style-type: none"> • Less than 6 A at high power (13.6 V) • Standby: 600 mA • Receive: 2 A

Transmitter

Channels	All available US, International and Canadian VHF marine bands
Frequency Range	156.000 MHz to 157.425 MHz / 155.500 MHz to 161.425 MHz (Private channels)
Frequency stability	+/- 1.5 ppm
Channel Spacing	12.5 kHz
Power Output	<ul style="list-style-type: none"> • Low power setting — 1 W • High power setting — 25 W
Spurious emissions	Better than -36 dBm at 25 W (Less than 0.25 μW)
Maximum deviation	+/- 5 KHz
Antenna impedance	50 Ohms (typical)

Receiver

Receiver type	Double conversion super heterodyne
Channels	All available US, International and Canadian VHF marine bands
Frequency range	156.050 MHz to 163.275 MHz / 155.500 MHz to 161.425 MHz (Private channels)
Sensitivity	Better than 1 microvolt EMF @ 20dB SINAD
Squelch sensitivity	Less than -2 dBμ EMF
Hum and noise	Better than -40 dB
Audio distortion	Less than 10%

Receiver sensitivity	<ul style="list-style-type: none"> • Distance — 119dBm (0.25uV) @ 12dB SINAD (typical) • Local — 110dBm (0.7uV) @ 12dB SINAD (typical)
Adjacent channel selectivity	More than 70 dB
Spurious response rejection	More than 70 dB
Inter modulation rejection	More than 68 dB

Speakers

Base station speaker power output	2.5 W (8 Ω)
Fismic speaker power output	1 W (16 Ω)
External speaker power output	5 W (4 Ω) / 2.5 W (8 Ω)
Handset speaker power output	1 W (16 Ω)

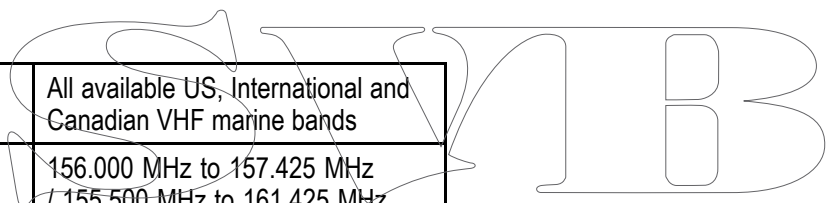

13.3 Technical specification — Ray70

Environmental specification

Operating temperature	-20°C (-4°F) to +60°C (140°F)
Storage temperature	-25°C (-13°F) to +70°C (158°F)
Relative humidity	95%
Water proofing	IPX6 & IPX7
Connections	<ul style="list-style-type: none"> • 1 x NMEA 0183 • 1 x SeaTalk^{ng}® / NMEA 2000 • 1 x Front Fistmic connection • 1 x Rear connection for 2nd station • 1 x Audio (RCA) • 1 x Loud Hailer connection

Power specification

Nominal supply voltage	12 V dc (Reverse polarity and over voltage protection)
Operating voltage range	9 V dc to 16 V dc
Current consumption	<ul style="list-style-type: none"> • Less than 6 A at high power (13.6 V) • Standby: 600 mA • Receive: 2 A • Loud hailer: 3 A (8 Ω) / 6 A (4 Ω)

Transmitter

Channels	All available US, International and Canadian VHF marine bands
Frequency Range	156.000 MHz to 157.425 MHz / 155.500 MHz to 161.425 MHz (Private channels)
Frequency stability	+/- 1.5 ppm
Channel Spacing	12.5 kHz
Power Output	<ul style="list-style-type: none"> • Low power setting — 1 W • High power setting — 25 W
Spurious emissions	Better than -36 dBm at 25 W (Less than 0.25 μW)
Maximum deviation	+/- 5 KHz
Antenna impedance	50 Ohms (typical)

Receiver

Receiver type	Double conversion super heterodyne
Channels	All available US, International and Canadian VHF marine bands
Frequency range	156.050 MHz to 163.275 MHz / 155.500 MHz to 161.425 MHz (Private channels)
Sensitivity	Better than 1 microvolt EMF @ 20dB SINAD
Squelch sensitivity	Less than -2 dBμ EMF

Hum and noise	Better than -40 dB
Audio distortion	Less than 10%
Receiver sensitivity	<ul style="list-style-type: none"> • Distance — 119dBm (0.25uV) @ 12dB SINAD (typical) • Local — 110dBm (0.7uV) @ 12dB SINAD (typical)
Adjacent channel selectivity	More than 70 dB
Spurious response rejection	More than 70 dB
Inter modulation rejection	More than 68 dB

Speakers

Base station speaker power output	2.5 W (8 Ω)
Fistmic speaker power output	1 W (16 Ω)
External speaker power output	5 W (4 Ω) / 2.5 W (8 Ω)
Handset speaker power output	1 W (16 Ω)
Hailer speaker power output	25 W (4 Ω) / 12 W (8 Ω)

AIS

Class type	AIS receiver only
------------	-------------------

GPS

Channels	72
Cold start	<2 minutes
Receiver IC Sensitivity	-167 dBm (Tracking) / -148 dBm (Acquisition)
GNSS compatibility	<ul style="list-style-type: none"> • GPS • GLONASS • * Beidou
SBAS compatibility	<ul style="list-style-type: none"> • WAAS • EGNOS • MSAS
Special features	Active Jamming and Interference Reduction
Operating frequency	<ul style="list-style-type: none"> • GPS L1 C/A • GLONASS L10F • Beidou B1
Signal Acquisition	Automatic
Almanac Update	Automatic
Geodetic Datum	WGS-84 (alternatives available through Raymarine MFD)
Refresh Rate	10 Hz (10 times per second Concurrent GNSS)

Antenna	<ul style="list-style-type: none"> • Internal — Ceramic chip mounted near top of unit
Position Accuracy	<ul style="list-style-type: none"> • Without SBAS: <= 15 metres 95% of the time • With SBAS: <= 5 metres 95% of the time

13.4 Radio usage

The radio can be used worldwide, including the following European countries:

AT	CZ	FI	IE	LU	PL	SK
BE	DE	FR	IS	LV	PT	TR
BG	DK	GB	IT	MT	RO	
CH	EE	GR	LI	NL	SE	
CY	ES	HU	LT	NO	SI	

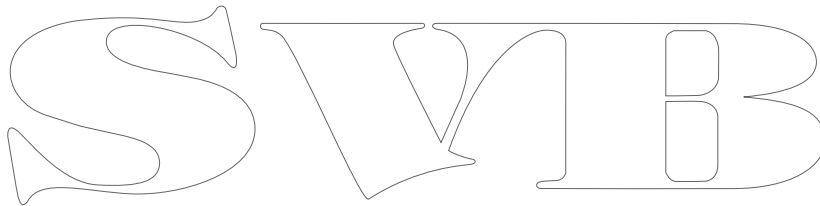

The image shows a large, stylized outline logo for 'SVIB'. The letters are bold and interconnected, with a decorative, slightly calligraphic feel. The 'S' is on the left, followed by 'V', 'I', and 'B' on the right.

SWIB

Chapter 14: Spares and accessories



Chapter contents

- 14.1 Spares on page 100
- 14.2 Accessories — **Ray60** / **Ray70** on page 100
- 14.3 SeaTalk^{ng} cables and accessories on page 101

SWIB

14.1 Spares

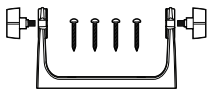
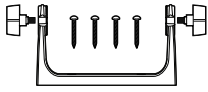
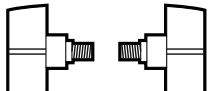
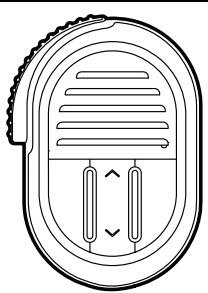
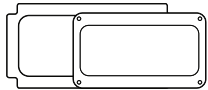
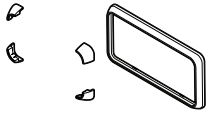
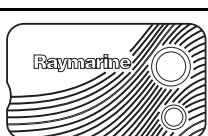
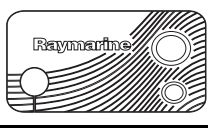
The following spares are available for your product.

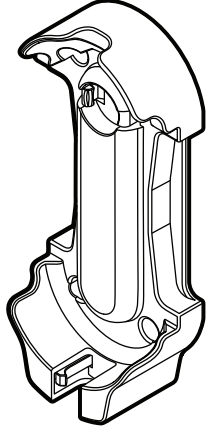
Item	Description	Part number
	Ray50 Bracket (trunnion) mount	R70417
	Ray60 / Ray70 Bracket (trunnion) mount	R70418
	Replacement bracket (trunnion) knob set	R70456
	Replacement Ray60 / Ray70 Fistmic	R70430
	Ray50 / Ray60 / Ray70 Panel seal kit	R70434
	Ray50 (black screw covers) / Ray60 / Ray70 (Gunmetal bezel) kit	R70435
	Ray50 sun cover	R70437
	Ray60 / Ray70 sun cover	R70436
	Panel mount fixings kit	R70438
	Ray60 / Ray70 Raymic handset cradle	A80301

14.2 Accessories — Ray60 / Ray70

The following accessories are available for the **Ray60** and **Ray70** your product.

Raymic Handset Kit	A80289
Raymic Handset extension cable 5 m (16.4 ft.)	A80291
Raymic Handset extension cable 10 m (32.8 ft.)	A80292
Raymic Handset extension cable 15 m (49.2 ft.)	A80290
Fistmic adaptor cable (8 pin F to 12 pin M) 400 mm (15.7 in.)	A80296
Raymic Handset adaptor cable (12 pin F to 12 pin M with RCA audio)	A80297
Black bezel	A80333
Loud hailer / horn (Ray70 only)	M95435

14.3 SeaTalk^{ng} cables and accessories

SeaTalk^{ng} cables and accessories for use with compatible products.

Description	Part No	Notes
SeaTalk ^{ng} starter kit	T70134	Includes: <ul style="list-style-type: none"> • 1 x 5 Way connector (A06064) • 2 x Backbone terminator (A06031) • 1 x 3 m (9.8 ft) spur cable (A06040) • 1 x Power cable (A06049)
SeaTalk ^{ng} Backbone Kit	A25062	Includes: <ul style="list-style-type: none"> • 2 x 5 m (16.4 ft) Backbone cable (A06036) • 1 x 20 m (65.6 ft) Backbone cable (A06037) • 4 x T-piece (A06028) • 2 x Backbone terminator (A06031) • 1 x Power cable (A06049)
SeaTalk ^{ng} 0.4 m (1.3 ft) spur	A06038	
SeaTalk ^{ng} 1 m (3.3 ft) spur	A06039	
SeaTalk ^{ng} 3 m (9.8 ft) spur	A06040	
SeaTalk ^{ng} 5 m (16.4 ft) spur	A06041	
SeaTalk ^{ng} 0.4 m (1.3 ft) elbow spur	A06042	
SeaTalk ^{ng} 0.4 m (1.3 ft) backbone	A06033	
SeaTalk ^{ng} 1 m (3.3 ft) backbone	A06034	
SeaTalk ^{ng} 3 m (9.8 ft) backbone	A06035	
SeaTalk ^{ng} 5 m (16.4 ft) backbone	A06036	
SeaTalk ^{ng} 9 m (29.5 ft) backbone	A06068	
SeaTalk ^{ng} 20 m (65.6 ft) backbone	A06037	
SeaTalk ^{ng} to bare ends 1 m (3.3 ft) spur	A06043	
SeaTalk ^{ng} to bare ends 3 m (9.8 ft) spur	A06044	

Description	Part No	Notes
SeaTalk ^{ng} Power cable	A06049	
SeaTalk ^{ng} Terminator	A06031	
SeaTalk ^{ng} T-piece	A06028	Provides 1 x spur connection
SeaTalk ^{ng} 5-way connector	A06064	Provides 3 x spur connections
SeaTalk ^{ng} backbone extender	A06030	
SeaTalk to SeaTalk ^{ng} converter kit	E22158	Allows the connection of SeaTalk devices to a SeaTalk ^{ng} system.
SeaTalk ^{ng} Inline terminator	A80001	Provides direct connection of a spur cable to the end of a backbone cable. No T-piece required.
SeaTalk ^{ng} Blanking plug	A06032	
ACU / SPX SeaTalk ^{ng} spur cable 0.3 m (1.0 ft)	R12112	Connects an SPX course computer or an ACU to a SeaTalk ^{ng} backbone.
SeaTalk (3 pin) to SeaTalk ^{ng} adaptor cable 0.4 m (1.3 ft)	A06047	
SeaTalk to SeaTalk ^{ng} spur 1 m (3.3 ft) spur	A22164	
SeaTalk2 (5 pin) to SeaTalk ^{ng} adaptor cable 0.4 m (1.3 ft)	A06048	
DeviceNet adaptor cable (Female)	A06045	Allows the connection of NMEA 2000 devices to a SeaTalk ^{ng} system.
DeviceNet adaptor cable (Male)	A06046	Allows the connection of NMEA 2000 devices to a SeaTalk ^{ng} system.
DeviceNet adaptor cable (Female) to bare ends.	E05026	Allows the connection of NMEA 2000 devices to a SeaTalk ^{ng} system.
DeviceNet adaptor cable (Male) to bare ends.	E05027	Allows the connection of NMEA 2000 devices to a SeaTalk ^{ng} system.

SWIB

Appendix A NMEA 0183 sentences

The radio supports the following **NMEA 0183** sentences.

Sentence	Description	Ray50 / Ray60		Ray70	
		Receive	Transmit	Receive	Transmit
DSC	Digital Selective Calling		•		•
DSE	Expanded Digital Selective Calling		•		•
VDM	AIS VHF Data Link Message				•
GGA	Global Positioning System Fix Data	•		•	
GLL	Geographic Position — Lat/Long	•		•	
GNS	GNSS Fix Data	•		•	
RMA	Recommended Minimum Specific Loran-C Data	•		•	
RMC	Recommended Minimum Specific GNSS Data	•		•	
DTM	Datum	•		•	

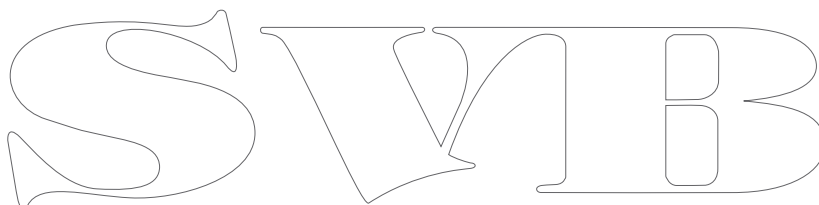

SVMB

Appendix B NMEA 2000 PGN List

The radio supports the following **NMEA 2000** PGNs. These are applicable to **NMEA 2000** and **SeaTalk^{ng}** protocols.

PGN	Description	Ray50 / Ray60		Ray70	
		Receive	Transmit	Receive	Transmit
59392	ISO Request	•	•	•	•
59904	ISO Acknowledgement	•	•	•	•
60928	ISO Address Claim	•	•	•	•
126208	NMEA — Group Function	•	•	•	•
126464	PGN List		•		•
126996	Product Information		•		•
127258	Magnetic variation	•		•	
129026	COG / SOG Rapid Update	•		•	
129029	GNSS Position Data	•		•	
129038	AIS Class A Position Report				•
129039	AIS Class B Position Report				•
129040	AIS Class B Extended Position Report				•
129041	AIS Aids to Navigation (AtONs)				•
129044	Datum	•		•	
129793	AIS UTC and Date Report				•
129794	AIS Class A Static and Voyage Related data				•
129798	AIS SAR Aircraft Position Report				•
129801	AIS Addressed Safety Related Message				•
129802	AIS Safety Related Broadcast Message				•
129808	DSC Call Information		•		•
129809	AIS Class B "CS" Static Data Report, Part A				•
129810	AIS Class B "CS" Static Data Report, Part B				•

Appendix C VHF Channels

US Marine VHF Channels and Frequencies

CH No.	TX Freq	RX Freq	Single Freq	Use
01A	156.050	156.050	x	Port operations and commercial, VTS. Available only in New Orleans / Lower Mississippi area.
03A	156.150	156.150	x	US Government only.
05A	156.250	156.250	x	Port operations or VTS in the Houston, New Orleans and Seattle areas.
06	156.300	156.300	x	Intership Safety.
07A	156.350	156.350	x	Commercial.
08	156.400	156.400	x	Commercial (Intership only).
09	156.450	156.450	x	Boater calling. Commercial and Non-commercial.
10	156.500	156.500	x	Commercial.
11	156.550	156.550	x	Commercial. VTS in selected areas.
12	156.600	156.600	x	Port operations. VTS in selected areas.
13	156.650	156.650	x	Intership navigation safety (Bridge-to-bridge). Ships >20 metres in length maintain a listening watch on this channel in US waters.
14	156.700	156.700	x	Port operations. VTS in selected areas.
15	-	156.750	x	Environmental (Receive only). Used by Class 'C' EPIRBs.
16	156.800	156.800	x	International Distress, Safety and Calling. Ships required to carry radio, USCG, and most coast stations maintain a listening watch on this channel.
17	156.850	156.850	x	State Control.
18A	156.900	156.900	x	Commercial.
19A	156.950	156.950	x	Commercial.
20	157.000	161.600		Port operations (duplex).
20A	157.000	157.000	x	Port operations.
21A	157.050	157.050	x	US Coast Guard only.
22A	157.100	157.100	x	Coast Guard Liaison and Maritime Safety Information Broadcasts. Broadcasts announced on channel 16.
23A	157.150	157.150	x	US Coast Guard only.
24	157.200	161.800		Public correspondence (Marine operator).
25	157.250	161.850		Public correspondence (Marine operator).
26	157.300	161.900		Public correspondence (Marine operator).
27	157.350	161.950		Public correspondence (Marine operator).
28	157.400	162.000		Public correspondence (Marine operator).
61A	156.075	156.075	x	US Government only.
63A	156.175	156.175	x	Port operations and commercial VTS, Available only in New Orleans / Lower Mississippi area.
64A	156.225	156.225	x	US Coast Guard only.
65A	156.275	156.275	x	Port operations.

CH No.	TX Freq	RX Freq	Single Freq	Use
66A	156.325	156.325	x	Port operations.
67	156.375	156.375	x	Commercial. Used for bridge-to-bridge communications in lower Mississippi river (Intership only).
68	156.425	156.425	x	Non-commercial.
69	156.475	156.475	x	Non-commercial.
71	156.575	156.575	x	Non-commercial.
72	156.625	156.625	x	Non-commercial (Intership only).
73	156.675	156.675	x	Port operations.
74	156.725	156.725	x	Port operations.
77	156.875	156.875	x	Port operations (Intership only).
78A	156.925	156.925	x	Non-commercial.
79A	156.975	156.975	x	Commercial. Non-commercial in Great Lakes only).
80A	157.025	157.025	x	Commercial. Non-commercial in Great Lakes only).
81A	157.075	157.075	x	US Government only — Environmental protection operations.
82A	157.125	157.125	x	US Government only.
83A	157.175	157.175	x	US Government only.
84	157.225	161.825		Public correspondence (Marine operator).
85	157.275	161.875		Public correspondence (Marine operator).
86	157.325	161.925		Public correspondence (Marine operator).
87	157.375	161.975		Public correspondence (Marine operator).
88	157.425	162.025		Public correspondence only near the Canadian border
88A	157.425	157.425	x	Commercial, Intership only.

Please be aware that:

- Recreational boaters normally use channels listed as Non-commercial: 68, 69, 71, 72 78A.
- Channel 70 is used exclusively for DSC and is not available for regular voice communications.
- Channels 75 and 76 are reserved as guards bands for channel 16 and are not available for regular voice communications.

Note:

1. The letter 'A' following a channel number indicates simplex use of the ship station transmit side of an international semi-duplex channel. Operations are different from that of international operations on that channel.
2. Channel 13 should be used to contact a ship when there is danger of collision. All ships of length 20 metres or greater are required to guard VHF channel 13, in addition to VHF channel 16, when operating within US territorial waters.
3. Channel 15 is receive only.
4. Channel 16 is used for calling other stations or for distress calls.
5. Channel 17 and channel 77 have a fixed power output of 1 watt.
6. Channel 13 and channel 67 have an initial power output of 1 watt. User can temporarily override this restrictions to transmit at high power.

Canadian Marine VHF Channels and Frequencies

CH No.	TX Freq	RX Freq	Area of operation	Use
01	156.050	160.650	PC	Public correspondence.
02	156.100	160.700	PC	Public correspondence.
03	156.150	160.750	PC	Public correspondence.
04A	156.200	156.200	PC	Intership, ship/shore and safety: Canadian Coast Guard search and rescue.
04A	156.200	156.200	EC	Intership, ship/shore and commercial: Commercial fishing only.
05A	156.250	156.250		Ship movement.
06	156.300	156.300	All areas	Intership, commercial, non-commercial and safety: Maybe used for search and rescue communications between ships and aircraft.
07A	156.350	156.350	All areas	Intership, ship/shore, commercial.
08	156.400	156.400	WC, EC	Intership, commercial and safety. Also assigned for operations in the Lake Winnipeg area.
09	156.450	156.450	AC	Intership, ship/shore, commercial, non-commercial and ship movement. Maybe used to communicate with aircraft and helicopters in predominantly maritime support operations.
10	156.500	156.500	AC, GL	Intership, ship/shore, commercial, non-commercial, safety and ship movement. May also be used for communications with aircraft engaged in coordinated search and rescue and antipollution operations.
11	156.550	156.550	PC, AC, GL	Intership, ship/shore, commercial, non-commercial and ship movement. Also used for pilotage purposes.
12	156.600	156.600	WC, AC, GL	Intership, ship/shore, commercial, non-commercial and ship movement. Port operations and pilot information and messages.
13	156.650	156.650	All areas	Intership, commercial, non-commercial and ship movement. Exclusively for bridge-to-bridge navigational traffic. Limited to 1 watt maximum power.
14	156.700	156.700	AC, GL	Intership, ship/shore, commercial, non-commercial and ship movement. Port operations and pilot information and messages.
15	156.750	156.750	All areas	Intership, ship/shore, commercial, non-commercial and ship movement. All operations limited to 1 watt maximum power. May also be used for on-board communications.
16	156.800	156.800	All areas	International distress, safety and calling.
17	156.850	156.850	All areas	Intership, ship/shore, commercial, non-commercial and ship movement. All operations limited to 1 watt maximum power. May also be used for on-board communications.
18A	156.900	156.900	All areas	Intership, ship/shore, commercial. Towing on the Pacific coast.
19A	156.950	156.950	All areas except PC	Intership, ship/shore. Canadian Coast Guard only
19A	156.950	156.950	PC	Intership, ship/shore. Various government departments.
20	157.00	161.600	All areas	Ship/shore, safety and ship movement. Port operations limited to 1 watt maximum power.
21A	157.050	157.050	All areas	Intership and ship/shore. Canadian Coast Guard only.
21B	-	161.650	All areas	Safety: Continuous Marine Broadcast (CMB) service.

CH No.	TX Freq	RX Freq	Area of operation	Use
22A	157.100	157.100	All areas	Intership, ship/shore, commercial and non-commercial. For communications between Canadian Coast Guard and non-Canadian Coast Guard stations only.
23	157.150	161.750	PC	Ship/shore and public correspondence. Also in the inland waters of British Columbia
24	157.200	161.800	All areas	Ship/shore and public correspondence.
25	157.250	161.850	PC	Ship/shore and public correspondence. Also assigned for operations in the Lake Winnipeg area.
25B	-	161.850	AC	Safety: Continuous Marine Broadcast (CMB) service.
26	157.300	161.900	All areas	Ship/shore, safety and public correspondence.
27	157.350	161.950	AC, GL, PC	Ship/shore and public correspondence.
28	157.400	162.00	PC	Ship/shore, safety and public correspondence.
28B	-	162.000	AC	Safety: Continuous Marine Broadcast (CMB) service.
60	156.025	160.625	PC	Ship/shore and public correspondence.
61A	156.075	156.075	PC	Intership and ship/shore Canadian Coast Guard only.
61A	156.075	156.075	EC	Intership, ship/shore and commercial Commercial fishing only.
62A	156.125	156.125	PC	Intership and ship/shore Canadian Coast Guard only.
62A	156.125	156.125	EC	Intership, ship/shore and commercial Commercial fishing only.
64	156.225	160.825	PC	Ship/shore and public correspondence.
64A	156.225	156.225	EC	Intership, ship/shore and commercial Commercial fishing only.
65A	156.275	156.275		Intership, ship/shore, commercial, non-commercial and safety. Search and rescue and antipollution operations on the Great Lakes. Towing on the Pacific coast. Port operations only in the St. Lawrence river area limited to 1 watt maximum power. Pleasure craft in the inland waters of Alberta, Saskatchewan and Manitobas (excluding Lake Winnipeg and the Red River.
66A	156.325	156.325		Intership, ship/shore, commercial, non-commercial, safety and ship movement. Port operations only in the St. Lawrence river / Great Lakes areas limited to 1 watt maximum power.
67	156.375	156.375	EC	Intership ship/shore and commercial. Commercial fishing only.
67	156.375	156.375	All areas except EC	Intership, ship/shore, commercial, non-commercial, safety. May also be used for communications with aircraft engaged in coordinated search and rescue and antipollution operations.
68	156.425	156.425	All areas	Intership, ship/shore and non-commercial. For marinas and yacht clubs.
69	156.475	156.475	All areas except EC	Intership, ship/shore, commercial and non-commercial.
69	156.475	156.475	EC	Intership, ship/shore and commercial. Commercial fishing only.
71	156.575	156.575	PC	Intership, ship/shore, commercial, non-commercial, safety and ship movement.
71	156.575	156.575		Intership, ship/shore and non-commercial. For marinas and yacht clubs on the east coast and on Lake Winnipeg.

CH No.	TX Freq	RX Freq	Area of operation	Use
72	156.625	156.625	EC, PC	Intership, commercial and non-commercial May be used to communicate with aircraft and helicopters in predominantly maritime support operations.
73	156.675	156.675	EC	Intership, ship/shore and commercial. Commercial fishing only.
73	156.675	156.675	All areas except EC	Intership, ship/shore, commercial, non-commercial and safety. May also be used for communications with aircraft engaged in coordinated search and rescue and antipollution operations.
74	156.725	156.725	EC, PC	Intership, ship/shore, commercial, non-commercial and ship movement.
77	156.875	156.875		Intership, ship/shore, safety and ship movement. Pilotage on Pacific coast. Port operations only in the St. Lawrence river / Great Lakes areas limited to 1 watt maximum power.
78A	156.925	156.925	EC, PC	Intership, ship/shore and commercial.
79A	156.975	156.975	EC, PC	Intership, ship/shore and commercial.
80A	157.025	157.025	EC, PC	Intership, ship/shore and commercial.
81A	157.075	157.075		Intership, ship/shore. Canadian Coast Guard use only in the St. Lawrence river / Great Lakes areas.
81A	157.075	157.075	PC	Intership, ship/shore and safety. Canadian Coast Guard antipollution.
82A	157.125	157.125	PC	Intership, ship/shore and safety. Canadian Coast Guard use only.
82A	157.125	157.1258		Intership and ship/shore. Canadian Coast Guard use only in the St. Lawrence river / Great Lakes areas.
83	157.175	161.775	PC	Ship/shore and safety. Canadian Coast Guard use only.
83A	157.175	157.175	EC	Intership and ship/shore Canadian Coast Guard and other government agencies.
83B	-	161.775	AC, GL	Safety: Continuous Marine Broadcast (CMB) service.
84	157.225	161.825	PC	Ship/shore and public correspondence.
85	157.275	161.875	AC, GL, NL	Ship/shore and public correspondence.
86	157.325	161.925	PC	Ship/shore and public correspondence.
87	157.375	161.975	AC, GL, NL	Ship/shore and public correspondence.
88	157.425	162.025	AC, GL, NL	Ship/shore and public correspondence.

Area of operation

- **AC** — Atlantic Coast, Gulf and St. Lawrence River up to and including Montreal.
- **EC** — East Coast: includes NL, AC, GL and Eastern Arctic areas.
- **GL** — Great Lakes: includes St. Lawrence above Montreal.
- **NL** — Newfoundland and Labrador.
- **PC** — Pacific Coast.
- **WC** — West Coast: includes PC, Western Arctic and Athabasca-Mackenzie Watershed areas.
- **All areas** — Includes East and West Coast areas.

Note:

1. An 'A' following a channel number indicates simplex use of the ship station transmit side of an international duplex channel. Operations are different from that of international operations on that channel.
2. Channel 16 is used for calling other stations or for distress calls.
3. A 'B' following a channel number indicates simplex use of the coast station transmit side of an international duplex channel. The channel is receive only
4. Channel 70 is used exclusively for Digital Selective Calling and is not available for regular voice communications.
5. Channel 75 and channel 76 are reserved as guard bands for channel 16 and are not available for regular voice communications.

International Marine VHF Channels and Frequencies

CH No.	TX Freq	RX Freq	Single Freq	Use
01	156.050	160.650		Public correspondence, Port operations and Ship movement.
02	156.100	160.700		Public correspondence, Port operations and Ship movement.
03	156.150	160.750		Public correspondence, Port operations and Ship movement.
04	156.200	160.800		Public correspondence, Port operations and Ship movement.
05	156.250	160.850		Public correspondence, Port operations and Ship movement.
06	156.300	156.300	x	Intership.
07	156.350	160.950		Public correspondence, Port operations and Ship movement.
08	156.400	156.400	x	Intership.
09	156.450	156.450	x	Intership, Port operations and Ship movement.
10	156.500	156.500	x	Intership, Port operations and Ship movement.
11	156.550	156.550	x	Port operations and Ship movement.
12	156.600	156.600	x	Port operations and Ship movement.
13	156.650	156.650	x	Intership, Safety, Port operations and Ship movement.
14	156.700	156.700	x	Port operations and Ship movement.
15	156.750	156.750	x	Intership, on-board communications limited to 1 watt maximum power.
16	156.800	156.800	x	Distress, Safety and Calling
17	156.850	156.850	x	Intership, on-board communications limited to 1 watt maximum power.
18	156.900	161.500		Public correspondence, Port operations and Ship movement.
19	156.950	161.550		Public correspondence, Port operations and Ship movement.
20	157.000	161.600		Public correspondence, Port operations and Ship movement.
21	157.050	161.650		Public correspondence, Port operations and Ship movement.
22	157.100	161.700		Public correspondence, Port operations and Ship movement.
23	157.150	161.750		Public correspondence, Port operations and Ship movement.
24	157.200	161.800		Public correspondence, Port operations and Ship movement.
25	157.250	161.850		Public correspondence, Port operations and Ship movement.
26	157.300	161.900		Public correspondence, Port operations and Ship movement.
27	157.350	161.950		Public correspondence, Port operations and Ship movement.
28	157.400	162.000		Public correspondence, Port operations and Ship movement.
60	156.025	160.625		Public correspondence, Port operations and Ship movement.
61	156.075	160.675		Public correspondence, Port operations and Ship movement.
62	156.125	160.725		Public correspondence, Port operations and Ship movement.

CH No.	TX Freq	RX Freq	Single Freq	Use
63	156.175	160.775		Public correspondence, Port operations and Ship movement.
64	156.225	160.825		Public correspondence, Port operations and Ship movement.
65	156.275	160.875		Public correspondence, Port operations and Ship movement.
66	156.325	160.925		Public correspondence, Port operations and Ship movement.
67	156.375	156.375	x	Intership, Port operations and Ship movement.
68	156.425	156.425	x	Port operations and Ship movement.
69	156.475	156.475	x	Intership, Port operations and Ship movement.
71	156.575	156.575	x	Port operations and Ship movement.
72	156.625	156.625	x	Intership.
73	156.675	156.675	x	Intership.
74	156.725	156.725	x	Port operations and Ship movement.
75	156.775	156.775	x	See Note 5.
76	156.825	156.825	x	See Note 5.
77	156.875	156.875	x	Intership.
78	156.925	161.525		Public correspondence, Port operations and Ship movement.
79	156.975	161.575		Public correspondence, Port operations and Ship movement.
80	157.025	161.625		Public correspondence, Port operations and Ship movement.
81	157.075	161.675		Public correspondence, Port operations and Ship movement.
82	157.125	161.725		Public correspondence, Port operations and Ship movement.
83	157.175	161.775		Public correspondence, Port operations and Ship movement.
84	157.225	161.825		Public correspondence, Port operations and Ship movement.
85	157.275	161.875		Public correspondence, Port operations and Ship movement.
86	157.325	161.925		Public correspondence, Port operations and Ship movement.
87	157.375	157.375	x	Port operations and Ship movement.
88	157.425	157.425	x	Port operations and Ship movement.

Please be aware that:

- Intership channels are for communications between ship stations. Intership communications should be restricted to channels 6, 8, 72 and 77. If these are not available, the other channels marked for Intership may be used.
- Channel 70 is used exclusively for Digital Selective Calling (DSC) and is not available for regular voice communications.

Note:

1. Channel 06 may also be used for communications between ship stations and aircraft engaged in coordinated search and rescue operations. Ship stations should avoid harmful interference to such communications on channel 06 as well as to communications between aircraft stations, ice breakers and assisted ships during ice seasons.
2. Within the European Maritime Area and in Canada, channels 10, 67 and 73 may also be used by the individual administrations concerned for communication between ship stations, aircraft stations and participating land stations engaged in coordinated search and rescue and anti-pollution operations in local areas. Channel 10 or 73 (depending on location) are also used for the broadcast of Marine Safety Information by the Maritime and Coast Guard Agency in the UK only.
3. Channel 13 is designated for use on a worldwide basis as a navigation safety communication channel, primarily for intership navigation safety communications.
4. Channels 15 and 17 may also be used for on-board communications provided the effective radiated power does not exceed 1 Watt.

5. The use of channels 75 and 76 should be restricted to navigation related communications only and all precautions should be taken to avoid harmful interference to channel 16. Transmit power is limited to 1 Watt.

Private Channels (Europe only)

Country	Channel Designations	TX Freq	RX Freq	Channel Use
Belgium	96	162.425	162.425	Marina
Denmark	L1	155.500	155.500	Pleasure
	L2	155.525	155.525	Pleasure
Finland, Norway & Sweden	L1	155.500	155.500	Pleasure
	L2	155.525	155.525	Pleasure
	L3	155.650	155.650	Pleasure
Holland (Netherlands)	31	157.550	162.150	Marina
	37	157.850	157.850	Leisure
Denmark, Finland, Norway & Sweden	F1	155.625	155.625	Fishing
	F2	155.775	155.775	Fishing
	F3	155.825	155.825	Fishing
United Kingdom	M1	157.850	157.850	Marina
	M2	161.425	161.425	Marina

The national channels listed above have been allocated for the specific use within the countries listed. To use these channels you must have the appropriate license.

WX Channels (North America only)

Weather Channel	Frequency in MHz
WX1	162.550
WX2	162.400
WX3	162.475
WX4	162.425
WX5	162.450
WX6	162.500
WX7	162.525
WX8	161.650
WX9	161.775
WX10	163.275

Appendix D Phonetic alphabet

To help make call letters more clearly understood, and to assist in spelling out similar sounding or unfamiliar word, radiotelephone users employ the international phonetic alphabet.

A	ALPHA	N	NOVEMBER
B	BRAVO	O	OSCAR
C	CHARLIE	P	PAPA
D	DELTA	Q	QUEBEC
E	ECHO	R	ROMEO
F	FOXTROT	S	SIERRA
G	GOLF	T	TANGO
H	HOTEL	U	UNIFORM
I	INDIA	V	VICTOR
J	JULIET	W	WHISKEY
K	KILO	X	X-RAY
L	LIMA	Y	YANKEE
M	MIKE	Z	ZULU

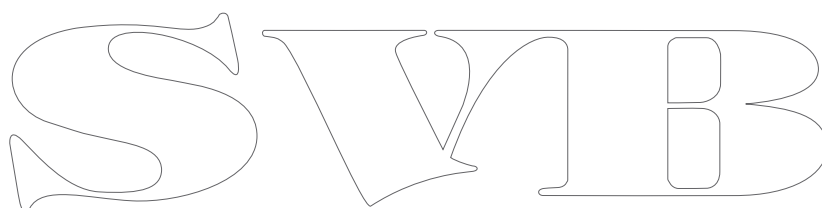
A large graphic of the letters 'S', 'W', 'I', and 'B' in a stylized, outlined font. The letters are white with black outlines and are arranged horizontally. The 'S' is on the left, followed by 'W', 'I', and 'B' on the right.

Appendix E Prowords

Prowords can be used to simplify and speed up radio communications.

Proword	Meaning
ACKNOWLEDGE	Have you received and understood?
CONFIRM	Is that correct?
CORRECTION	An error has been made?
I SAY AGAIN	I repeat (e.g. important information).
I SPELL	Phonetically spelling of the word.
OUT	End of communication.
OVER	I have completed this part of the message and am inviting you to reply.
RECEIVED	Receipt acknowledgement.
SAY AGAIN	Repeat your message.
STATION CALLING	Used when a station is uncertain of the identity of a station which is calling.

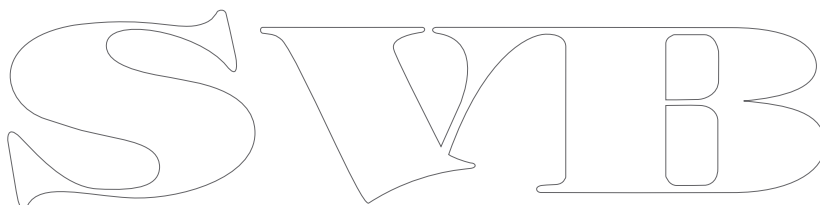
A large graphic of the letters 'SWIB' in a stylized, outlined font. The letters are white with black outlines and are arranged horizontally. The 'S' is on the left, followed by 'W', 'I', and 'B' on the right.

SWIB

Raymarine[®]
BY  **FLIR**[®]
SVIB