

# Quick guide – Alarm function

## Connecting MOB+ Wireless Man OverBoard System as an alarm



### NOTE

Do not touch or cut any existing wires or electrically conducting components before you make sure the main voltage switch is OFF. Only set the main voltage switch to ON after you are finished cutting and connecting wires. Make sure that all wires and conductive connection points are free from corrosion before connecting any wires.

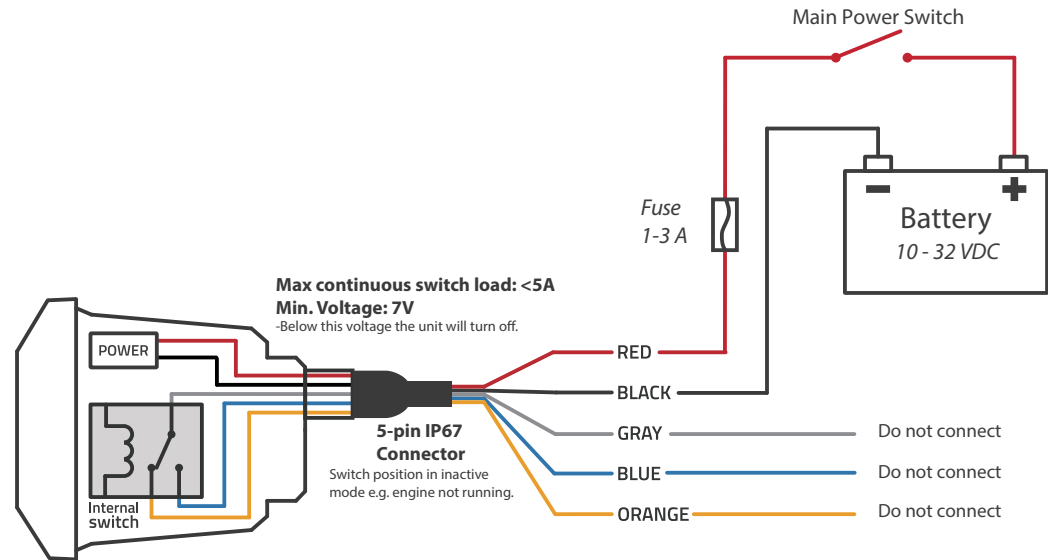

### Connecting the Power

- (10-30 Vdc)
1. Use a test light or a voltmeter to determine the polarity of the voltage source.
  2. Connect the red (+ or positive) wire to the positive voltage terminal. (If you use the fuse block on the boat, route the positive connection through the fuse, as shown on the diagram.)
  3. Connect the black (- or ground) wire to the negative voltage terminal.
  4. Install or check the 1-3 A fuse (in the in-line fuse holder, or on the fuse block of the boat).
  5. Use wire hoods suitable for the wire dimension (20AWG, 0.75mm<sup>2</sup>) or connection point on the fuse block.

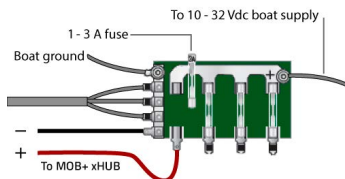

### NOTE

The maximum MOB+ xHUB input voltage is 32 Vdc. Do not exceed this voltage because this can damage the MOB+ xHUB and void the warranty.

### NOTE

Use an AGC / 3AG - 1-3 Amp replacement fuse. If it is necessary to extend the power and ground wires, use 20 AWG or thicker wire. You can wire the Power Wires directly to the main boat battery, or if your boat has an electrical system, you might be able to wire the Power Wires to an unused holder on the fuse block. In any case it should be after the main power switch to avoid current drainage when the boat is left unattended.

It is very important that the MOB+ gets supplied power from a stable source which is not susceptible to voltage drops as if it gets below 7V supply voltage, the unit will restart and stop your engine.

### Connecting Signal wires

To use MOB+ solely as an alarm signaling if a person falls over board, none of the signal wires needs to be connected. Please make sure that the wires are isolated so that the conducting part of the wires do not touch each other or anything else.

### NOTE

Make sure that all wire connections are waterproof by using heat shrinkable butt splices or similar when connecting wires.

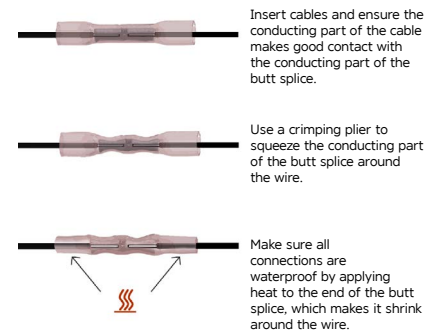

### Installing MOB+ in a metal boat

If your helm is made out of conducting materials the wireless signals from MOB+ may be degraded. The amount of signal degradation experienced may vary from across boats and must be tested for each case. If the signal is very poor you can install a separate external antenna outside of your helm to increase the signal strength. Please contact FELL support at [www.fellmarine.com/support](http://www.fellmarine.com/support) for more information.

© FELL Technology AS, Nedre Storgate 46, N-3015, Drammen, Norway, FELL, WIMEA®, WIMEA® Protocol, WIMEA® Protocol and its logos are trademarks of FELL AS, its subsidiaries and affiliates. The shape and design of this product are a trade dress of FELL AS, subsidiaries and affiliates. NMEA®, NMEA 2000®, and the NMEA 2000 logo are registered trademarks of the National Marine Electronics Association. All other trademarks or registered trademarks are the property of their respective owners. Designed in Norway. Made in China and Taiwan. All rights reserved. Product features, appearances and specifications may be subject to change without notice. Read all instructions carefully before use. Visit [www.fell.no/support](http://www.fell.no/support) for complete Owner's Manual. Please retain this information for future reference.

# Quick guide Evinrude/BRP

## Installing MOB+ Wireless Man OverBoard System

### IMPORTANT NOTICE!

The function of the kill switch must be tested after installation to verify that it stops the engine in the event of an emergency situation.

**NOTE**

Do not touch or cut any existing wires or electrically conducting components before you make sure the main voltage switch is OFF. Only set the main voltage switch to ON after you are finished cutting and connecting wires. Make sure that all wires and conductive connection points are free from corrosion before connecting any wires.

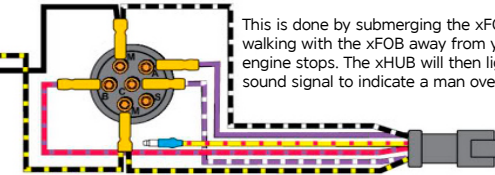
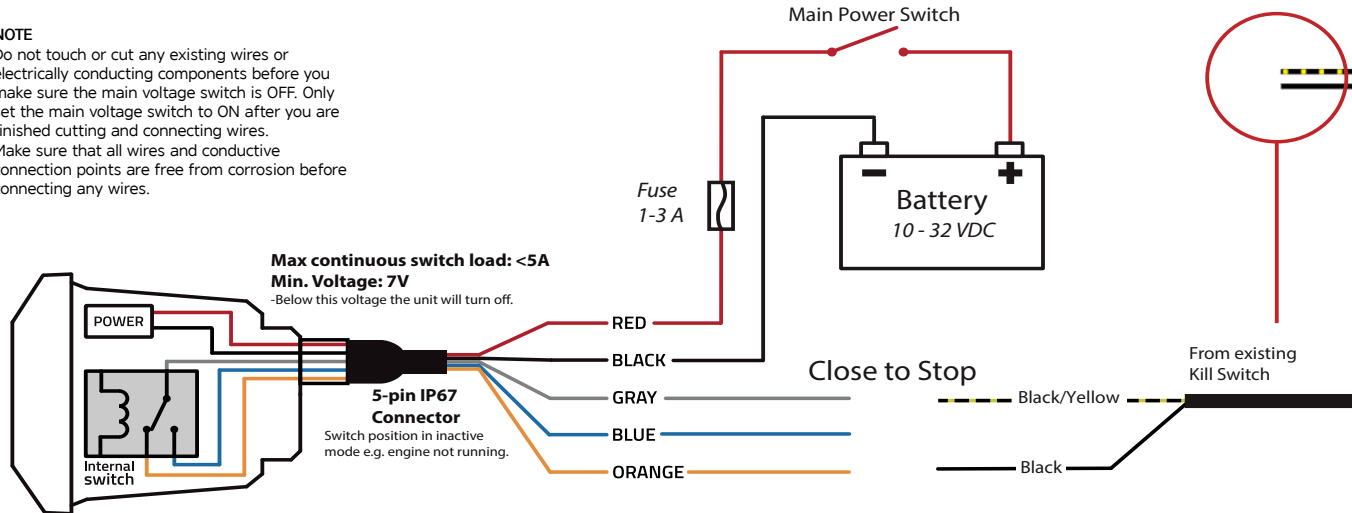

This is done by submerging the xFOB in water or walking with the xFOB away from your boat until the engine stops. The xHUB will then light red and give a sound signal to indicate a man over board event.

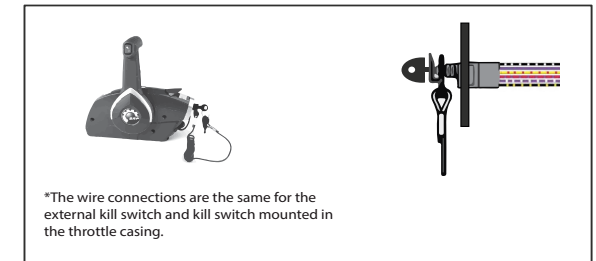

### Connecting the Power

- (10-30 Vdc)
1. Use a test light or a voltmeter to determine the polarity of the voltage source.
  2. Connect the red (+ or positive) wire to the positive voltage terminal. (If you use the fuse block on the boat, route the positive connection through the fuse, as shown on the diagram.)
  3. Connect the black (- or ground) wire to the negative voltage terminal.
  4. Install or check the 1-3 A fuse (in the in-line fuse holder, or on the fuse block of the boat).
  5. Use wire hoods suitable for the wire dimension (20AWG, 0.75mm<sup>2</sup>) or connection point on the fuse block.

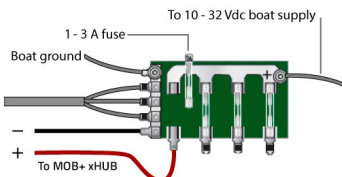

**NOTE**

The maximum MOB+ xHUB input voltage is 32 Vdc. Do not exceed this voltage because this can damage the MOB+ xHUB and void the warranty.

**NOTE**

Use an AGC / 3AG - 1-3 Amp replacement fuse. If it is necessary to extend the power and ground wires, use 20 AWG or thicker wire. You can wire the Power Wires directly to the main boat battery, or if your boat has an electrical system, you might be able to wire the Power Wires to an unused holder on the fuse block. In any case it should be after the main power switch to avoid current drainage when the boat is left unattended.

It is very important that the MOB+ gets supplied power from a stable source which is not susceptible to voltage drops as if it gets below 7V supply voltage, the unit will restart and stop your engine.

### Keep existing kill switch

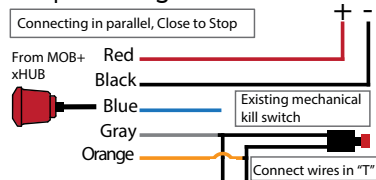

MOB+ can be installed together with your existing kill switch by connecting it in series or parallel. If you should connect in series or parallel depends on your existing kill switch function. The above picture shows an example with Close to Stop connection.

### Connecting Signal wires

The switching function inside xHUB is a double throw relay and can be connected to switch any circuit on and off, and thus perform the old kill switch function. Evinrude uses «Close to Stop» kill switch principle as standard. This means that the engine kill switch shorts circuits to stop the engine. We recommend to verify this by simply trying to start the engine(s), whilst the existing kill switch signal wires are not connected. See user manual for further instructions.

1. Common - Grey - Always used when connecting the MOB+ xHUB Signal wires.
2. Open to Stop (OS) - Blue - Used when existing system is a Open to Stop kill switch system.
3. Close to Stop (CS) - Orange - Used when your existing system is a Close to Stop kill switch system. This is the principle used by Evinrude.

### Installing MOB+ in a metal boat

If your helm is made out of conducting materials the wireless signals from MOB+ may be degraded. The amount of signal degradation experienced may vary from across boats and must be tested for each case. If the signal is very poor you can install a separate external antenna outside of your helm to increase the signal strength. Please contact FELL support at [www.fellmarine.com/support](http://www.fellmarine.com/support) for more information.

**NOTE**

Make sure that all wire connections are waterproof by using heat shrinkable butt splices or similar when connecting wires.

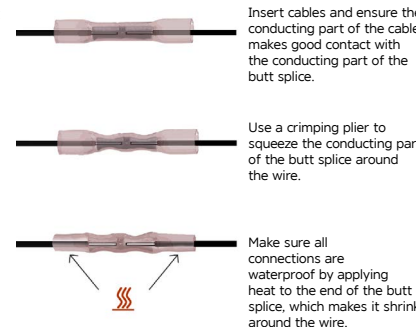

### Multiple engine configurations

If you have multiple engines on your boat and your boat is already fitted with a kill switch you can connect the wires as described above to the two existing signal wires leading to the existing mechanical switch in your helm or throttle.

In some cases the existing kill switch will have one pair of wires per engine and a MOB+ Multiple Engine Harness is needed. This splitter translates the signal from the single mechanical kill switch into a kill switch signal for multiple engines and so the MOB+ can be connected plug and play like a single engine installation. This can be ordered in your nearest MOB+ dealer.

Some engine brands also offer their own diode splitter, and can be ordered through your engine dealer.

**NOTE**

If you have multiple engines and do not have an existing kill switch, see user manual for this on [www.fellmarine.com/support](http://www.fellmarine.com/support). Please contact your local engine retailer or manufacturer for further assistance.

© FELL Technology AS, Nedre Storgate 46, N-3015, Drammen, Norway, FELL, WIMEA®, WIMEA® Protocol, WIMEA® Protocol and its logos are trademarks of FELL AS, its subsidiaries and affiliates. The shape and design of this product are a trade dress of FELL AS, subsidiaries and affiliates. NMEA®, NMEA 2000®, and the NMEA 2000 logo are registered trademarks of the National Marine Electronics Association. All other trademarks or registered trademarks are the property of their respective owners. Designed in Norway. Made in China and Taiwan. All rights reserved. Product features, appearance and specifications may be subject to change without notice. Read all instructions carefully before use. Visit [www.fell.no/support](http://www.fell.no/support) for complete Owner's Manual. Please retain this information for future reference.

## Quick guide Honda Installing MOB+ Wireless Man OverBoard System

### NOTE

Do not touch or cut any existing wires or electrically conducting components before you make sure the main voltage switch is OFF. Only set the main voltage switch to ON after you are finished cutting and connecting wires. Make sure that all wires and conductive connection points are free from corrosion before connecting any wires.

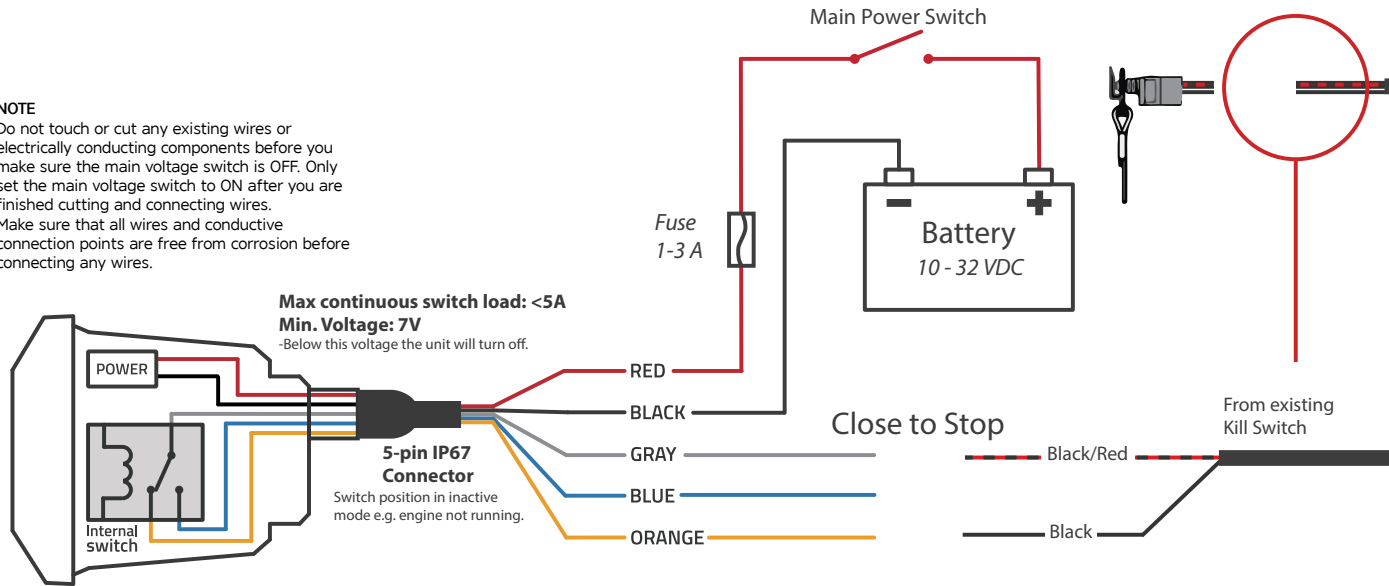

### IMPORTANT NOTICE!

The function of the kill switch must be tested after installation to verify that it stops the engine in the event of an emergency situation.

This is done by submerging the xFOB in water or walking with the xFOB away from your boat until the engine stops. The xHUB will then light red and give a sound signal to indicate a man over board event.



### Connecting the Power

- (10-30 Vdc)
1. Use a test light or a voltmeter to determine the polarity of the voltage source.
  2. Connect the red (+ or positive) wire to the positive voltage terminal. (If you use the fuse block on the boat, route the positive connection through the fuse, as shown on the diagram.)
  3. Connect the black (- or ground) wire to the negative voltage terminal.
  4. Install or check the 1-3 A fuse (in the in-line fuse holder, or on the fuse block of the boat).
  5. Use wire hoods suitable for the wire dimension (20AWG, 0.75mm<sup>2</sup>) or connection point on the fuse block.

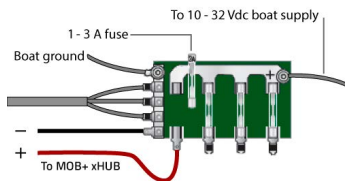

### NOTE

The maximum MOB+ xHUB input voltage is 32 Vdc. Do not exceed this voltage because this can damage the MOB+ xHUB and void the warranty.

### NOTE

Use an AGC / 3AG - 1-3 Amp replacement fuse. If it is necessary to extend the power and ground wires, use 20 AWG or thicker wire. You can wire the Power Wires directly to the main boat battery, or if your boat has an electrical system, you might be able to wire the Power Wires to an unused holder on the fuse block. In any case it should be after the main power switch to avoid current drainage when the boat is left unattended.

It is very important that the MOB+ gets supplied power from a stable source which is not susceptible to voltage drops as if it gets below 7V supply voltage, the unit will restart and stop your engine.

### Keep existing kill switch

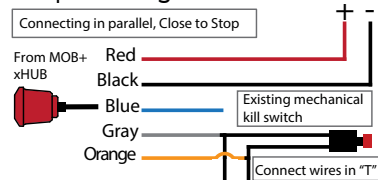

MOB+ can be installed together with your existing kill switch by connecting it in series or parallel. If you should connect in series or parallel depends on your existing kill switch function. The above picture shows an example with Close to Stop connection.

### Connecting Signal wires

The switching function inside xHUB is a double throw relay and can be connected to switch any circuit on and off, and thus perform the old kill switch function.

Honda uses «Close to Stop» kill switch principle as standard. This means that the engine kill switch shorts circuits to stop the engine. We recommend to verify this by simply trying to start the engine(s), whilst the existing kill switch signal wires are not connected. See the user manual for further instructions.

1. Common - Grey - Always used when connecting the MOB+ xHUB Signal wires.
2. Open to Stop (OS) - Blue - Used when your existing system is a Open to Stop kill switch system.
3. Close to Stop (CS) - Orange - Used when your existing system is a Close to Stop kill switch system. This is the principle used by Honda.

### Installing MOB+ in a metal boat

If your helm is made out of conducting materials the wireless signals from MOB+ may be degraded. The amount of signal degradation experienced may vary from across boats and must be tested for each case. If the signal is very poor you can install a separate external antenna outside of your helm to increase the signal strength. Please contact FELL support at [www.fellmarine.com/support](http://www.fellmarine.com/support) for more information.

### NOTE

Make sure that all wire connections are waterproof by using heat shrinkable butt splices or similar when connecting wires.

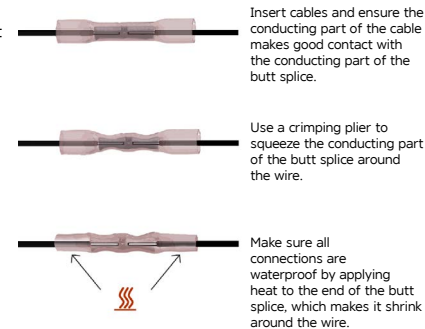

### Multiple engine configurations

If you have multiple engines on your boat and your boat is already fitted with a kill switch you can connect the wires as described above to the two existing signal wires leading to the existing mechanical switch in your helm or throttle.

In some cases the existing kill switch will have one pair of wires per engine and a MOB+ Multiple Engine Harness is needed. This splitter translates the signal from the single mechanical kill switch into a kill switch signal for multiple engines and so the MOB+ can be connected plug and play like a single engine installation. This can be ordered in your nearest MOB+ dealer.

Some engine brands also offer their own diode splitter, and can be ordered through your engine dealer.

### NOTE

If you have multiple engines and do not have an existing kill switch, see user manual for this on [www.fellmarine.com/support](http://www.fellmarine.com/support). Please contact your local engine retailer or manufacturer for further assistance.

© FELL Technology AS, Nedre Storgate 46, N-3015, Drammen, Norway. FELL, WIMEA®, WIMEA® Protocol, WIMEA® Protocol and its logos are trademarks of FELL AS, its subsidiaries and affiliates. The shape and design of this product are a trade dress of FELL AS, subsidiaries and affiliates. NMEA®, NMEA 2000®, and the NMEA 2000 logo are registered trademarks of the National Marine Electronics Association. All other trademarks or registered trademarks are the property of their respective owners. Designed in Norway. Made in China and Taiwan. All rights reserved. Product features, appearances and specifications may be subject to change without notice. Read all instructions carefully before use. Visit [www.fell.no/support](http://www.fell.no/support) for complete Owner's Manual. Please retain this information for future reference.

# Quick guide Mercury Installing MOB+ Wireless Man OverBoard System

**NOTE**

Do not touch or cut any existing wires or electrically conducting components before you make sure the main voltage switch is OFF. Only set the main voltage switch to ON after you are finished cutting and connecting wires. Make sure that all wires and conductive connection points are free from corrosion before connecting any wires.

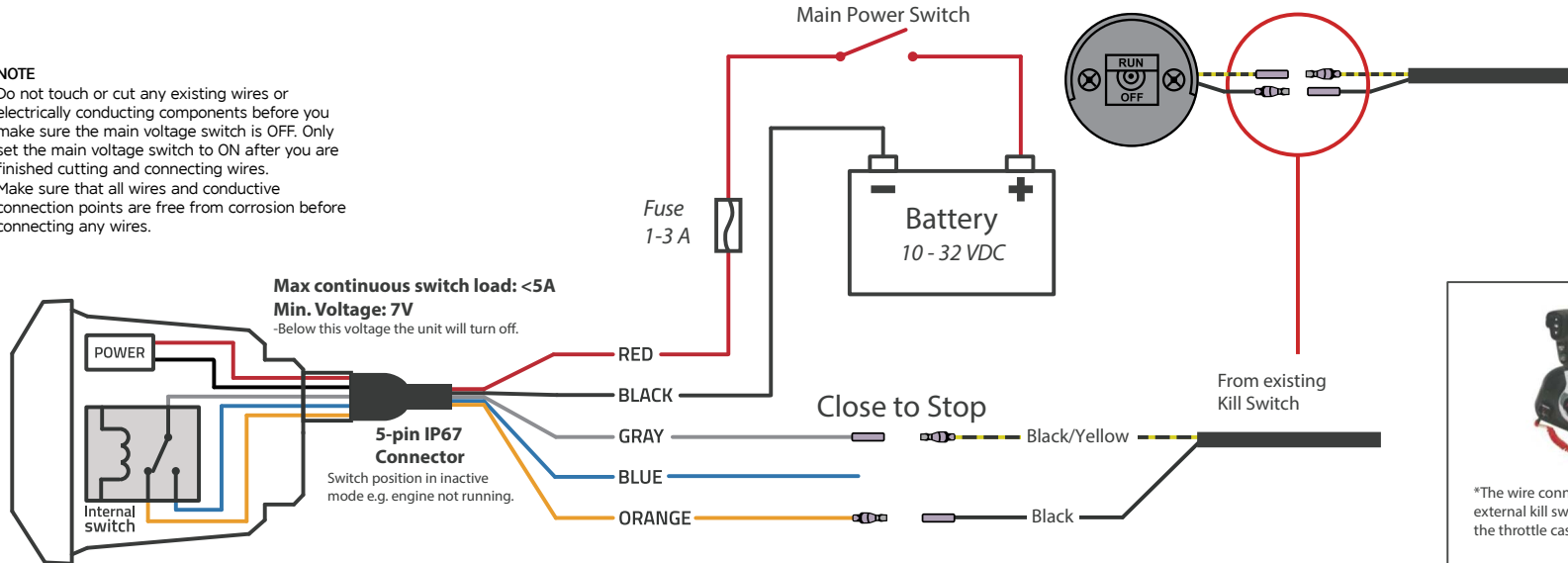

**IMPORTANT NOTICE!**

The function of the kill switch must be tested after installation to verify that it stops the engine in the event of an emergency situation.

This is done by submerging the xFOB in water or walking with the xFOB away from your boat until the engine stops. The xHUB will then light red and give a sound signal to indicate a man over board event.

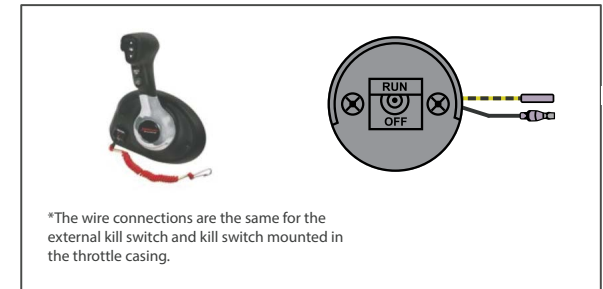

\*The wire connections are the same for the external kill switch and kill switch mounted in the throttle casing.

**Connecting the Power**

- (10-30 Vdc)
1. Use a test light or a voltmeter to determine the polarity of the voltage source.
  2. Connect the red (+ or positive) wire to the positive voltage terminal. (If you use the fuse block on the boat, route the positive connection through the fuse, as shown on the diagram.)
  3. Connect the black (- or ground) wire to the negative voltage terminal.
  4. Install or check the 1-3 A fuse (in the in-line fuse holder, or on the fuse block of the boat).
  5. Use wire hoods suitable for the wire dimension (20AWG, 0.75mm<sup>2</sup>) or connection point on the fuse block.

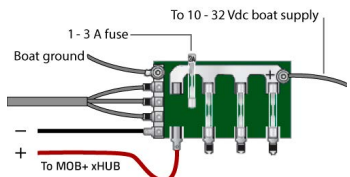

**NOTE**

The maximum MOB+ xHUB input voltage is 32 Vdc. Do not exceed this voltage because this can damage the MOB+ xHUB and void the warranty.

**NOTE**

Use an AGC / 3AG - 1-3 Amp replacement fuse. If it is necessary to extend the power and ground wires, use 20 AWG or thicker wire. You can wire the Power Wires directly to the main boat battery, or if your boat has an electrical system, you might be able to wire the Power Wires to an unused holder on the fuse block. In any case it should be after the main power switch to avoid current drainage when the boat is left unattended.

It is very important that the MOB+ gets supplied power from a stable source which is not susceptible to voltage drops as if it gets below 7V supply voltage, the unit will restart and stop your engine.

**Keep existing kill switch**

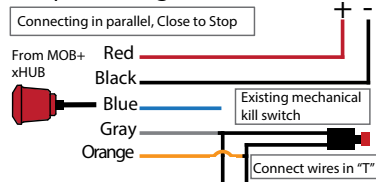

MOB+ Wireless Kill Switch can be installed together with your existing kill switch by connecting it in parallel. The above picture shows an example with Close to Stop connection as on Mercury engines.

**Connecting Signal wires**

The switching function inside xHUB is a double throw relay and can be connected to switch any circuit on and off, and thus perform the old kill switch function. Mercury uses «Close to Stop» kill switch principle as standard. This means that the engine kill switch shorts circuits to stop the engine. We recommend to verify this by simply trying to start the engine(s), whilst the existing kill switch signal wires are not connected. See the user manual for further instructions.

1. Common - Grey - Always used when connecting the MOB+ xHUB Signal wires.
2. Open to Stop (OS) - Blue - Used when your existing system is a Open to Stop kill switch system.
3. Close to Stop (CS) - Orange - Used when your existing system is a Close to Stop kill switch system. This is the principle used by Mercury.

**Installing MOB+ in a metal boat**

If your helm is made out of conducting materials the wireless signals from MOB+ may be degraded. The amount of signal degradation experienced may vary from across boats and must be tested for each case. If the signal is very poor you can install a separate external antenna outside of your helm to increase the signal strength. Please contact FELL support at [www.fellmarine.com/support](http://www.fellmarine.com/support) for more information.

**NOTE**  
Make sure that all wire connections are waterproof by using heat shrinkable butt splices or similar when connecting wires.

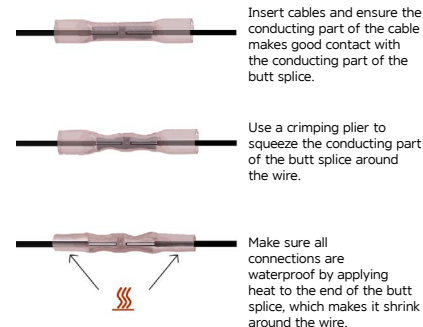

**Multiple engine configurations**

If you have several engines on your boat and your boat is already fitted with a kill switch you can connect the wires as described above to the two existing signal wires leading to the existing mechanical switch in your helm or throttle. You may notice that the existing wires consists of a splitter component on the wires. This splitter must not be removed, as this splitter translates the signal from the single mechanical kill switch into a kill switch signal for multiple engines. You should connect the MOB+ xHUB wires above this splitter, i.e. on the last two wires leading into the existing mechanical switch installed in your helm.

**NOTE**

If you have multiple engines and do not have an existing kill switch, wires and a splitter must be bought from your engine manufacturer or local retailer. Please contact your local engine retailer or manufacturer.



© FELL Technology AS, Nedre Storgate 46, N-3015, Drammen, Norway. FELL, WIMEA®, WIMEA® Protocol, WIMEA® Protocol and its logos are trademarks of FELL AS, its subsidiaries and affiliates. The shape and design of this product are a trade dress of FELL AS, subsidiaries and affiliates. NMEA®, NMEA 2000®, and the NMEA 2000 logo are registered trademarks of the National Marine Electronics Association. All other trademarks or registered trademarks are the property of their respective owners. Designed in Norway. Made in China and Taiwan. All rights reserved. Product features, appearance and specifications may be subject to change without notice. Read all instructions carefully before use. Visit [www.fell.no/support](http://www.fell.no/support) for complete Owner's Manual. Please retain this information for future reference.

# Quick guide Suzuki

## Installing MOB+ Wireless Man OverBoard System

**NOTE**

Do not touch or cut any existing wires or electrically conducting components before you make sure the main voltage switch is OFF. Only set the main voltage switch to ON after you are finished cutting and connecting wires. Make sure that all wires and conductive connection points are free from corrosion before connecting any wires.

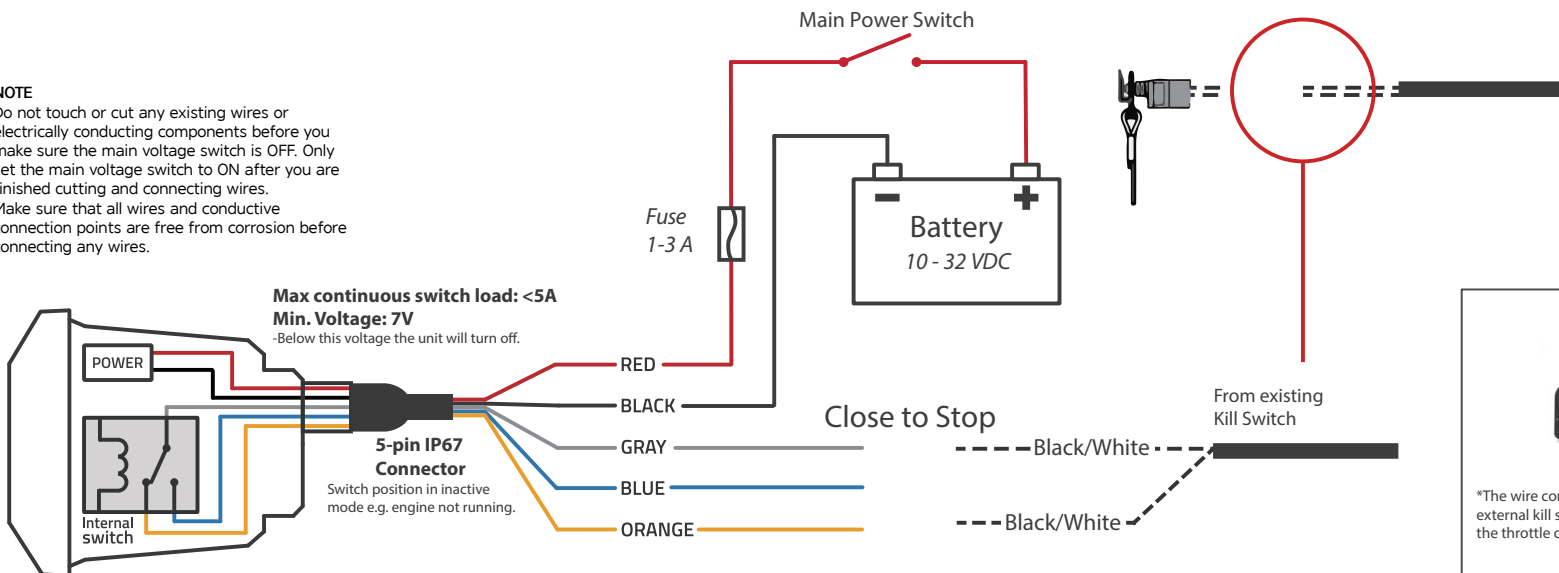

**IMPORTANT NOTICE!**

The function of the kill switch must be tested after installation to verify that it stops the engine in the event of an emergency situation.

This is done by submerging the xFOB in water or walking with the xFOB away from your boat until the engine stops. The xHUB will then light red and give a sound signal to indicate a man over board event.

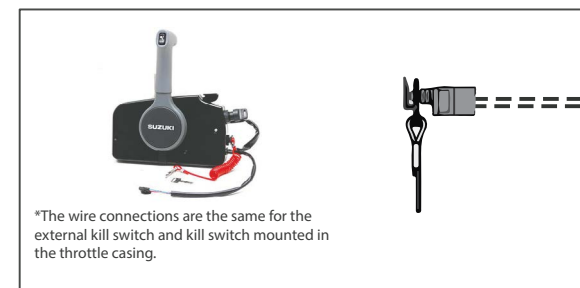

### Connecting the Power

- (10-30 Vdc)
1. Use a test light or a voltmeter to determine the polarity of the voltage source.
  2. Connect the red (+ or positive) wire to the positive voltage terminal. (If you use the fuse block on the boat, route the positive connection through the fuse, as shown on the diagram.)
  3. Connect the black (- or ground) wire to the negative voltage terminal.
  4. Install or check the 1-3 A fuse (in the in-line fuse holder, or on the fuse block of the boat).
  5. Use wire hoods suitable for the wire dimension (20AWG, 0.75mm<sup>2</sup>) or connection point on the fuse block.

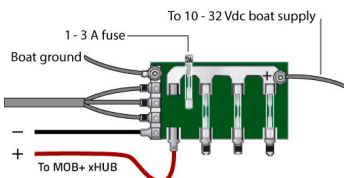

**NOTE**

The maximum MOB+ xHUB input voltage is 32 Vdc. Do not exceed this voltage because this can damage the MOB+ xHUB and void the warranty.

**NOTE**

Use an AGC / 3AG - 1-3 Amp replacement fuse. If it is necessary to extend the power and ground wires, use 20 AWG or thicker wire. You can wire the Power Wires directly to the main boat battery, or if your boat has an electrical system, you might be able to wire the Power Wires to an unused holder on the fuse block. In any case it should be after the main power switch to avoid current drainage when the boat is left unattended.

It is very important that the MOB+ gets supplied power from a stable source which is not susceptible to voltage drops as if it gets below 7V supply voltage, the unit will restart and stop your engine.

### Keep existing kill switch

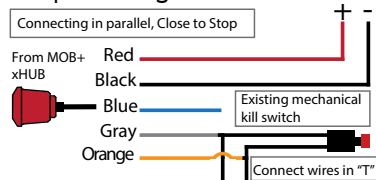

MOB+ can be installed together with your existing kill switch by connecting it in series or parallel. If you should connect in series or parallel depends on your existing kill switch function. The above picture shows an example with Close to Stop connection.

### Connecting Signal wires

The switching function inside xHUB is a double throw relay and can be connected to switch any circuit on and off, and thus perform the old kill switch function.

Suzuki uses «Close to Stop» kill switch principle as standard. This means that the engine kill switch shorts circuits to stop the engine. We recommend to verify this by simply trying to start the engine(s), whilst the existing kill switch signal wires are not connected. See the user manual for further instructions.

1. Common - Grey - Always used when connecting the MOB+ xHUB Signal wires.
2. Open to Stop (OS) - Blue - Used when your existing system is a Open to Stop kill switch system.
3. Close to Stop (CS) - Orange - Used when your existing system is a Close to Stop kill switch system. This is the principle used by Suzuki.

### Installing MOB+ in a metal boat

If your helm is made out of conducting materials the wireless signals from MOB+ may be degraded. The amount of signal degradation experienced may vary from across boats and must be tested for each case. If the signal is very poor you can install a separate external antenna outside of your helm to increase the signal strength. Please contact FELL support at [www.fellmarine.com/support](http://www.fellmarine.com/support) for more information.

**NOTE**

Make sure that all wire connections are waterproof by using heat shrinkable butt splices or similar when connecting wires.

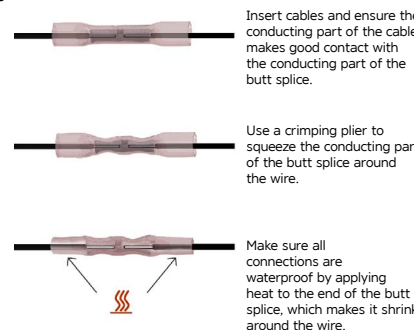

### Multiple engine configurations

If you have multiple engines on your boat and your boat is already fitted with a kill switch you can connect the wires as described above to the two existing signal wires leading to the existing mechanical switch in your helm or throttle.

In some cases the existing kill switch will have one pair of wires per engine and a MOB+ Multiple Engine Harness is needed. This splitter translates the signal from the single mechanical kill switch into a kill switch signal for multiple engines and so the MOB+ can be connected plug and play like a single engine installation. This can be ordered in your nearest MOB+ dealer.

Some engine brands also offer their own diode splitter, and can be ordered through your engine dealer.

**NOTE**

If you have multiple engines and do not have an existing kill switch, see user manual for this on [www.fellmarine.com/support](http://www.fellmarine.com/support). Please contact your local engine retailer or manufacturer for further assistance.

© FELL Technology AS, Nedre Storgate 46, N-3015, Drammen, Norway. FELL, WIMEA®, WIMEA® Protocol, WIMEA® Protocol and its logos are trademarks of FELL AS, its subsidiaries and affiliates. The shape and design of this product are a trade dress of FELL AS, subsidiaries and affiliates. NMEA®, NMEA 2000®, and the NMEA 2000 logo are registered trademarks of the National Marine Electronics Association. All other trademarks or registered trademarks are the property of their respective owners. Designed in Norway. Made in China and Taiwan. All rights reserved. Product features, appearances and specifications may be subject to change without notice. Read all instructions carefully before use. Visit [www.fell.no/support](http://www.fell.no/support) for complete Owner's Manual. Please retain this information for future reference.

# Quick guide Tohatsu

## Installing MOB+ Wireless Man OverBoard System

### NOTE

Do not touch or cut any existing wires or electrically conducting components before you make sure the main voltage switch is OFF. Only set the main voltage switch to ON after you are finished cutting and connecting wires. Make sure that all wires and conductive connection points are free from corrosion before connecting any wires.

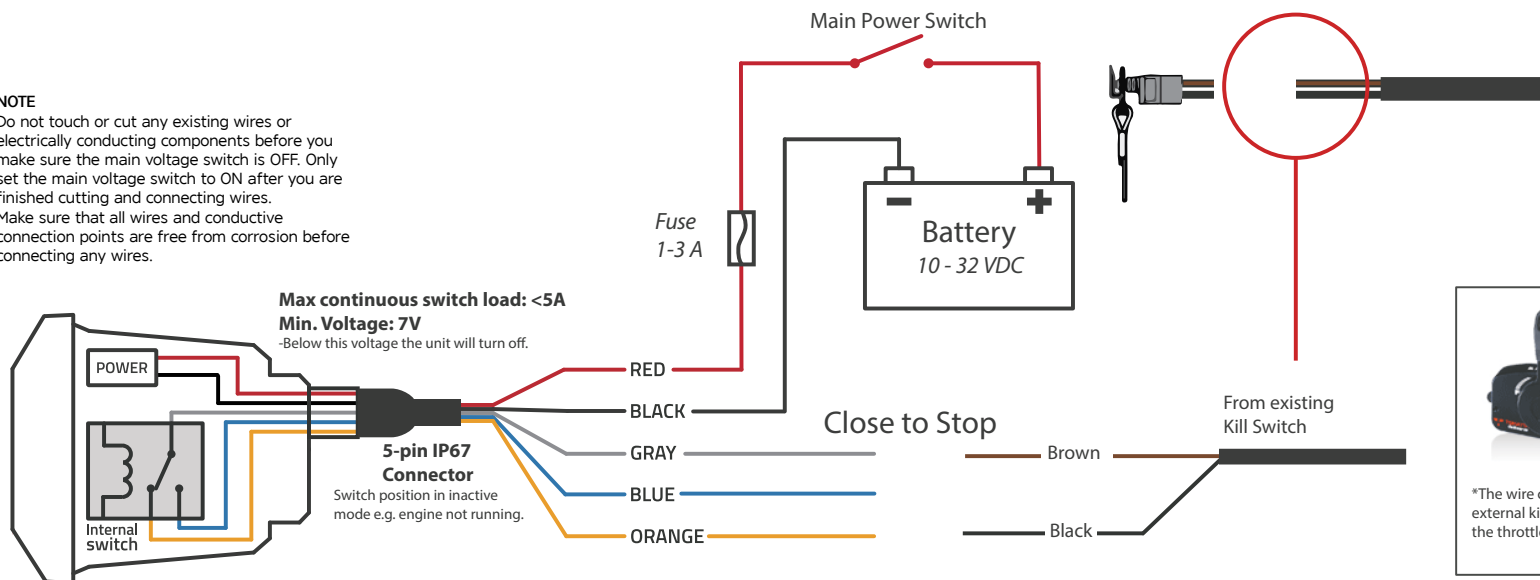

### IMPORTANT NOTICE!

The function of the kill switch must be tested after installation to verify that it stops the engine in the event of an emergency situation.

This is done by submerging the xFOB in water or walking with the xFOB away from your boat until the engine stops. The xHUB will then light red and give a sound signal to indicate a man over board event.

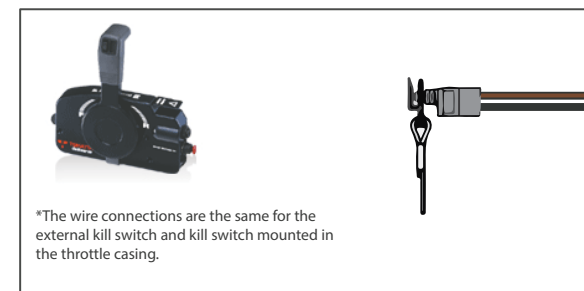

\*The wire connections are the same for the external kill switch and kill switch mounted in the throttle casing.

### Connecting the Power

- (10-30 Vdc)
1. Use a test light or a voltmeter to determine the polarity of the voltage source.
  2. Connect the red (+ or positive) wire to the positive voltage terminal. (If you use the fuse block on the boat, route the positive connection through the fuse, as shown on the diagram.)
  3. Connect the black (- or ground) wire to the negative voltage terminal.
  4. Install or check the 1-3 A fuse (in the in-line fuse holder, or on the fuse block of the boat).
  5. Use wire hoods suitable for the wire dimension (20AWG, 0.75mm<sup>2</sup>) or connection point on the fuse block.

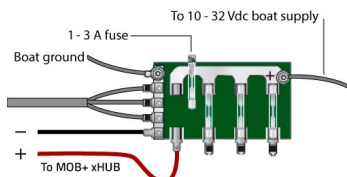

### NOTE

The maximum MOB+ xHUB input voltage is 32 Vdc. Do not exceed this voltage because this can damage the MOB+ xHUB and void the warranty.

### NOTE

Use an AGC / 3AG - 1-3 Amp replacement fuse. If it is necessary to extend the power and ground wires, use 20 AWG or thicker wire. You can wire the Power Wires directly to the main boat battery, or if your boat has an electrical system, you might be able to wire the Power Wires to an unused holder on the fuse block. In any case it should be after the main power switch to avoid current drainage when the boat is left unattended.

It is very important that the MOB+ gets supplied power from a stable source which is not susceptible to voltage drops as if it gets below 7V supply voltage, the unit will restart and stop your engine.

### Keep existing kill switch

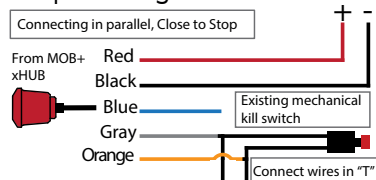

MOB+ can be installed together with your existing kill switch by connecting it in series or parallel. If you should connect in series or parallel depends on your existing kill switch function. The above picture shows an example with Close to Stop connection.

### Connecting Signal wires

The switching function inside xHUB is a double throw relay and can be connected to switch any circuit on and off, and thus perform the old kill switch function. Tohatsu uses «Close to Stop» kill switch principle as standard. This means that the engine kill switch shorts circuits to stop the engine.

We recommend to verify this by simply trying to start the engine(s), whilst the existing kill switch signal wires are not connected. See the user manual for further instructions.

1. Common - Grey - Always used when connecting the MOB+ xHUB Signal wires.
2. Open to Stop (OS) - Blue - Used when your existing system is a Open to Stop kill switch system.
3. Close to Stop (CS) - Orange - Used when your existing system is a Close to Stop kill switch system. This is the principle used by Tohatsu.

### Installing MOB+ in a metal boat

If your helm is made out of conducting materials the wireless signals from MOB+ may be degraded. The amount of signal degradation experienced may vary from across boats and must be tested for each case. If the signal is very poor you can install a separate external antenna outside of your helm to increase the signal strength. Please contact FELL support at [www.fellmarine.com/support](http://www.fellmarine.com/support) for more information.

### NOTE

Make sure that all wire connections are waterproof by using heat shrinkable butt splices or similar when connecting wires.

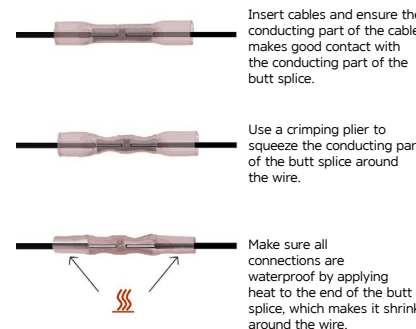

Insert cables and ensure the conducting part of the cable makes good contact with the conducting part of the butt splice.

Use a crimping plier to squeeze the conducting part of the butt splice around the wire.

Make sure all connections are waterproof by applying heat to the end of the butt splice, which makes it shrink around the wire.

### Multiple engine configurations

If you have multiple engines on your boat and your boat is already fitted with a kill switch you can connect the wires as described above to the two existing signal wires leading to the existing mechanical switch in your helm or throttle.

In some cases the existing kill switch will have one pair of wires per engine and a MOB+ Multiple Engine Harness is needed. This splitter translates the signal from the single mechanical kill switch into a kill switch signal for multiple engines and so the MOB+ can be connected plug and play like a single engine installation. This can be ordered in your nearest MOB+ dealer.

Some engine brands also offer their own diode splitter, and can be ordered through your engine dealer.

### NOTE

If you have multiple engines and do not have an existing kill switch, see user manual for this on [www.fellmarine.com/support](http://www.fellmarine.com/support). Please contact your local engine retailer or manufacturer for further assistance.

© FELL Technology AS, Nedre Storgate 46, N-3015, Drammen, Norway. FELL, WIMEA®, WIMEA® Protocol, WIMEA® Protocol and its logos are trademarks of FELL AS, its subsidiaries and affiliates. The shape and design of this product are a trade dress of FELL AS, subsidiaries and affiliates. NMEA®, NMEA 2000®, and the NMEA 2000 logo are registered trademarks of the National Marine Electronics Association. All other trademarks or registered trademarks are the property of their respective owners. Designed in Norway. Made in China and Taiwan. All rights reserved. Product features, appearances and specifications may be subject to change without notice. Read all instructions carefully before use. Visit [www.fell.no/support](http://www.fell.no/support) for complete Owner's Manual. Please retain this information for future reference.

## Quick guide Volvo Penta Installing MOB+ Wireless Man OverBoard system

### NOTE

Do not touch or cut any existing wires or electrically conducting components before you make sure the main voltage switch is OFF. Only set the main voltage switch to ON after you are finished cutting and connecting wires. Make sure that all wires and conductive connection points are free from corrosion before connecting any wires.

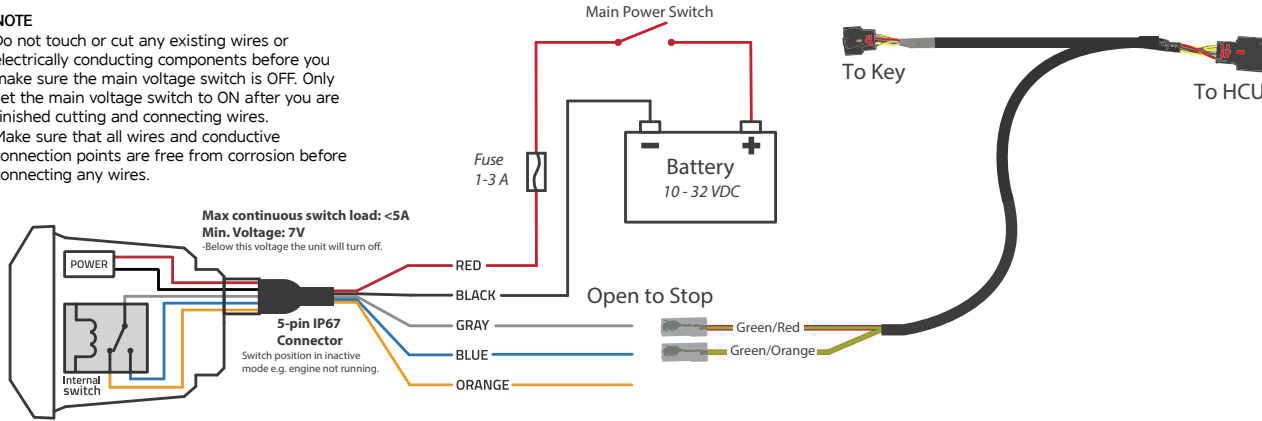

### Connecting the Power

- (10-32 Vdc)  
1. Use a test light or a voltmeter to determine the polarity of the voltage source.
2. Connect the red (+ or positive) wire to the positive voltage terminal. (If you use the fuse block on the boat, route the positive connection through the fuse, as shown on the diagram.)
3. Connect the black (- or ground) wire to the negative voltage terminal.
4. Install or check the 1-3 A fuse (in the in-line fuse holder, or on the fuse block of the boat).
5. Use wire hoods suitable for the wire dimension (20AWG, 0.75mm<sup>2</sup>) or connection point on the fuse block.

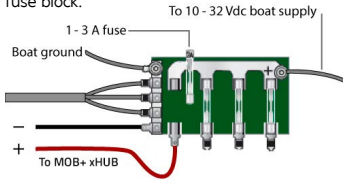

### NOTE

MAX Voltage for WIMEA Boat Unit is 32Vdc. Do not apply higher voltage as this will void your warranty and may break the unit.

### NOTE

Use an AGC / 3AG - 1-3 Amp replacement fuse. If it is necessary to extend the power and ground wires, use 20 AWG or thicker wire. You can wire the Power Wires directly to the main boat battery, or if your boat has an electrical system, you might be able to wire the Power Wires to an unused holder on the fuse block. In any case it should be after the main power switch to avoid current drainage when the boat is left unattended.

It is very important that the MOB+ gets supplied power from a stable source which is not susceptible to voltage drops as if it gets below 7V supply voltage, the unit will restart and stop your engine.

### Keep existing kill switch

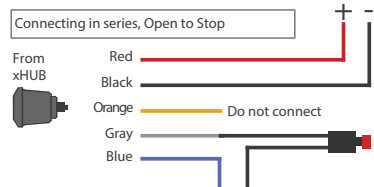

MOB+ can be installed together with your existing kill switch by connecting it in series or parallel. If you should connect in series or parallel depends on your existing kill switch function. The above picture shows an example with Normally Closed connection.

### Connect signal wires

To install MOB+ Wireless Man OverBoard System on a Volvo Penta, an original cable from Volvo Penta should be used. This cable can be ordered directly from your closest Volvo Penta dealer.

- The signal cables on MOB+ consists of three wires. Only two of these are used for installation.
1. **Common - Grey - Always used when connecting the MOB+ Boat Unit Signal wires.** Connect to green/red wire.
  2. **Open to Stop (OS) - Blue - Used when your existing system needs an open connection to stop as Volvo Penta EVC.**

Connect to green/orange wire.

FELL recommend that you use same type of crimp terminal as on the Volvo Penta cable when installing. This is to avoid breaking in the original Volvo Penta cable. After correct installation has been done the system needs to be autoconfigured. For more information on how to do this, contact your Volvo Penta Dealer.

### Installation in a metal boat

If your helm is made out of conducting materials the wireless signals from MOB+ may be degraded. The amount of signal degradation experienced may vary from across boats and must be tested for each case. If the signal is very poor you can install a separate external antenna outside of your helm to increase the signal strength. Please contact FELL support at [www.fellmarine.com/support](http://www.fellmarine.com/support) for more information.

### Autoconfiguration for EVC-D & EVC-E

If a kill switch has not previously been connected to your system, an Autoconfiguration needs to be done. The below illustration shows how to do this on EVC-D and EVC-E. The MOB+ Must be connected and active while doing the auto configuration.

### NOTE

Make sure that all wire connections are waterproof by using heat shrinkable butt splices or similar when connecting wires.

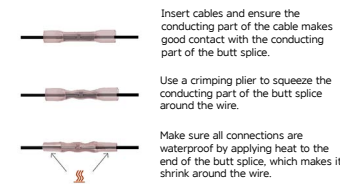

### EVC-D

In EVC-D there is an existing cable with part number 21469024, already fitted to the AKI unit. This cable can be connected in the same way as shown in "Connection signal wires". See illustration on right showing the cable.

### EVC-E

EVC-E with single engine uses a cable with part number 21693206. This is the cable illustrated in "Connection signal wires".

### EVC-E Twin

EVC-E with twin engines uses a cable with part number 21693206. This cable can be connected in the same way as shown in "Connection signal wires", except that there are two connectors to HCU.

### EVC-D Cable Illustration

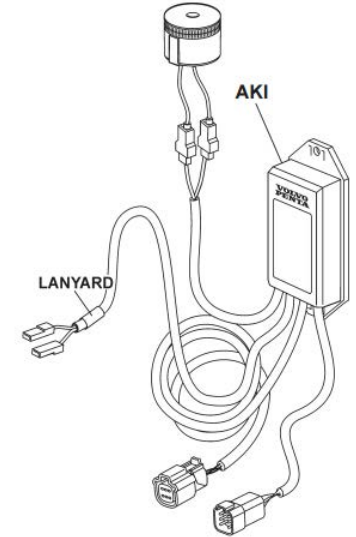

© FELL Technology AS, Nedre Storgate 46, N-3015, Drammen, Norway, FELL, WIMEA®, WIMEA® Protocol, WIMEA® Protocol and its logos are trademarks of FELL AS, its subsidiaries and affiliates. The shape and design of this product are a trade dress of FELL AS, subsidiaries and affiliates. NMEA®, NMEA 2000®, and the NMEA 2000 logo are registered trademarks of the National Marine Electronics Association. All other trademarks or registered trademarks are the property of their respective owners. Designed in Norway, Made in China and Taiwan. All rights reserved. Product features, appearance and specifications may be subject to change without notice. Read all instructions carefully before use. Visit [www.fell.no/support](http://www.fell.no/support) for complete Owner's Manual. Please retain this information for future reference.



# Quick guide Yamaha Installing MOB+ Wireless Man OverBoard System



## NOTE

Do not touch or cut any existing wires or electrically conducting components before you make sure the main voltage switch is OFF. Only set the main voltage switch to ON after you are finished cutting and connecting wires. Make sure that all wires and conductive connection points are free from corrosion before connecting any wires.

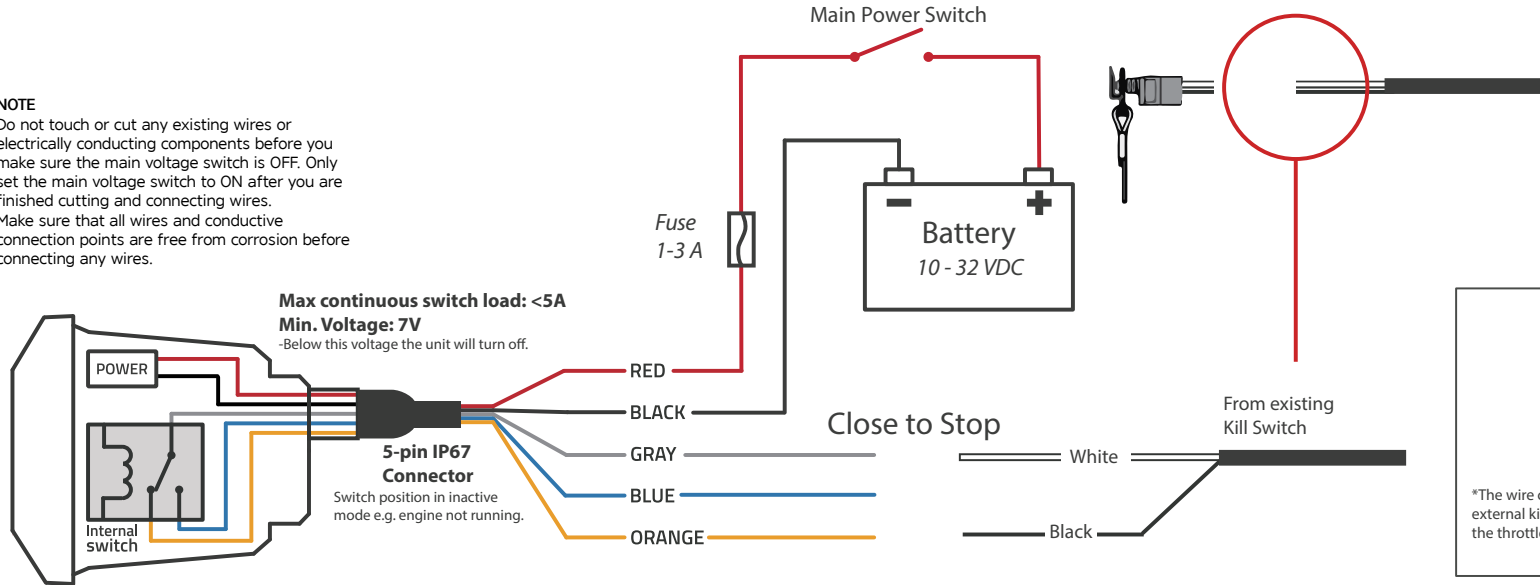

## IMPORTANT NOTICE!

The function of the kill switch must be tested after installation to verify that it stops the engine in the event of an emergency situation.

This is done by submerging the xFOB in water or walking with the xFOB away from your boat until the engine stops. The xHUB will then light red and give a sound signal to indicate a man over board event.

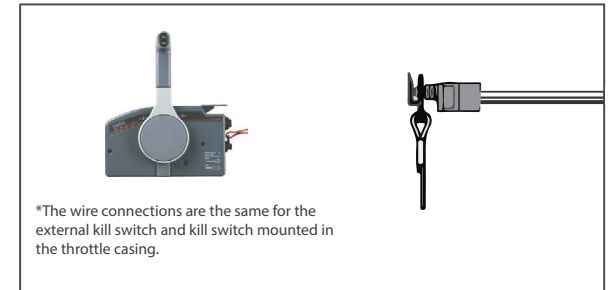

## Connecting the Power

(10-30 Vdc)

1. Use a test light or a voltmeter to determine the polarity of the voltage source.
2. Connect the red (+ or positive) wire to the positive voltage terminal. (If you use the fuse block on the boat, route the positive connection through the fuse, as shown on the diagram.)
3. Connect the black (- or ground) wire to the negative voltage terminal.
4. Install or check the 1-3 A fuse (in the in-line fuse holder, or on the fuse block of the boat).
5. Use wire hoods suitable for the wire dimension (20AWG, 0.75mm<sup>2</sup>) or connection point on the fuse block.

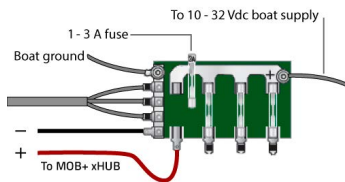

## NOTE

The maximum MOB+ xHUB input voltage is 32 Vdc. Do not exceed this voltage because this can damage the MOB+ xHUB and void the warranty.

## NOTE

Use an AGC / 3AG - 1-3 Amp replacement fuse. If it is necessary to extend the power and ground wires, use 20 AWG or thicker wire. You can wire the Power Wires directly to the main boat battery, or if your boat has an electrical system, you might be able to wire the Power Wires to an unused holder on the fuse block. In any case it should be after the main power switch to avoid current drainage when the boat is left unattended.

It is very important that the MOB+ gets supplied power from a stable source which is not susceptible to voltage drops as if it gets below 7V supply voltage, the unit will restart and stop your engine.

## Keep existing kill switch

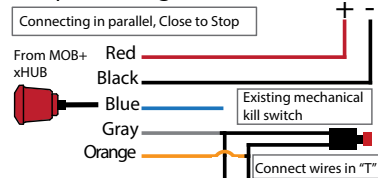

MOB+ can be installed together with your existing kill switch by connecting it in series or parallel. If you should connect in series or parallel depends on your existing kill switch function. The above picture shows an example with Close to Stop connection.

## Connecting Signal wires

The switching function inside xHUB is a double throw relay and can be connected to switch any circuit on and off, and thus perform the old kill switch function.

Yamaha uses «Close to Stop» kill switch principle as standard. This means that the engine kill switch shorts circuits to stop the engine.

We recommend to verify this by simply trying to start the engine(s), whilst the existing kill switch signal wires are not connected. See the user manual for further instructions.

1. Common - Grey - Always used when connecting the MOB+ xHUB Signal wires.
2. Open to Stop (OS) - Blue - Used when your existing system is a Open to Stop kill switch system.
3. Close to Stop (CS) - Orange - Used when your existing system is a Close to Stop kill switch system. This is the principle used by Yamaha.

## Installing MOB+ in a metal boat

If your helm is made out of conducting materials the wireless signals from MOB+ may be degraded. The amount of signal degradation experienced may vary from across boats and must be tested for each case. If the signal is very poor you can install a separate external antenna outside of your helm to increase the signal strength. Please contact FELL support at [www.fellmarine.com/support](http://www.fellmarine.com/support) for more information.

## NOTE

Make sure that all wire connections are waterproof by using heat shrinkable butt splices or similar when connecting wires.

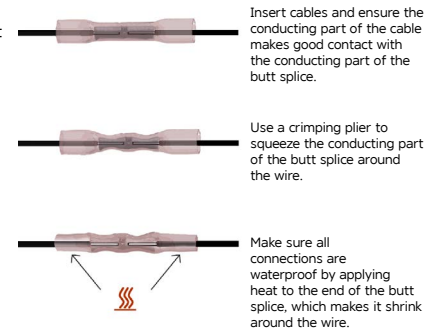

## Multiple engine configurations

If you have multiple engines on your boat and your boat is already fitted with a kill switch you can connect the wires as described above to the two existing signal wires leading to the existing mechanical switch in your helm or throttle.

In some cases the existing kill switch will have one pair of wires per engine and a MOB+ Multiple Engine Harness is needed. This splitter translates the signal from the single mechanical kill switch into a kill switch signal for multiple engines and so the MOB+ can be connected plug and play like a single engine installation. This can be ordered in your nearest MOB+ dealer.

Some engine brands also offer their own diode splitter, and can be ordered through your engine dealer.

## NOTE

If you have multiple engines and do not have an existing kill switch, see user manual for this on [www.fellmarine.com/support](http://www.fellmarine.com/support). Please contact your local engine retailer or manufacturer for further assistance.

© FELL Technology AS, Nedre Storgate 46, N-3015, Drammen, Norway. FELL, WIMEA®, WIMEA® Protocol, WIMEA® Protocol and its logos are trademarks of FELL AS, its subsidiaries and affiliates. The shape and design of this product are a trade dress of FELL AS, subsidiaries and affiliates. NMEA®, NMEA 2000®, and the NMEA 2000 logo are registered trademarks of the National Marine Electronics Association. All other trademarks or registered trademarks are the property of their respective owners. Designed in Norway. Made in China and Taiwan. All rights reserved. Product features, appearances and specifications may be subject to change without notice. Read all instructions carefully before use. Visit [www.fell.no/support](http://www.fell.no/support) for complete Owner's Manual. Please retain this information for future reference.





FELL Technology AS  
Designs, manuals and features subject  
to change. For more information visit our  
website: [www.fellmarine.com](http://www.fellmarine.com)

# MOB+™

MULTI ENGINE HARNESS

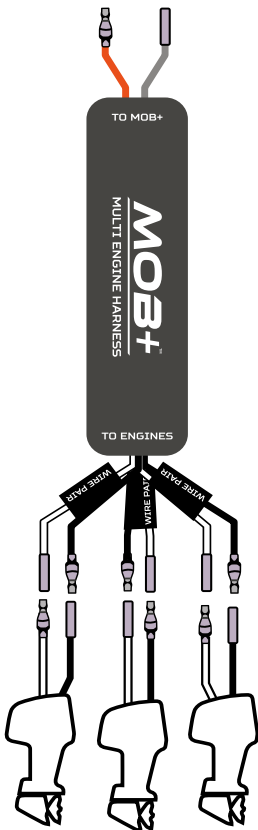

## MULTI ENGINE HARNESS FOR THE MOB+ WIRELESS MAN OVERBOARD SYSTEM

### ⚠ WARNING

**Disconnect battery cables at battery before attempting to install this product**

Read all instructions carefully before use of this product.

FELL Marine equipment and accessories are designed to the best industry standards for use in the recreational marine environment. Their design and manufacture conforms to the appropriate Electromagnetic Compatibility (EMC) regulations, but correct installation is required to ensure that performance is not compromised. Please see section EMC Installation Guidelines in the User Manual for optimum EMC conditions.

### ⚠ CAUTION

Within the wireless range MOB+ will not shut down the engine automatically e.g. if you fall in your boat within the wireless range the engine will not stop automatically. In this event, you can shut down the engine by pressing the button on your MOB+ xFOB or on the MOB+ xHUB. Always check your wireless range before use.

### Important information and caution

Read all instructions carefully before use of this product.

FELL Marine equipment and accessories are designed to the best industry standards for use in the recreational marine environment. Their design and manufacture conforms to the appropriate Electromagnetic Compatibility (EMC) regulations, but correct installation is required to ensure that performance is not compromised. Please see section EMC Installation Guidelines in the User Manual for optimum EMC conditions.

Within the wireless range MOB+ will not shut down the engine automatically e.g. if you fall in your boat within the wireless range the engine will not stop automatically. In this event, you can shut down the engine by pressing the button on your MOB+ xFOB or on the MOB+ xHUB. Always check your wireless range before use.

Make sure that the system is working properly before leaving the dock. Refer to the next page in this User Manual for instructions on how to use the system and information about normal system operations.

Always make sure to check the battery level sign on the xHUB before driving the boat. Confer with section Battery Indication in the User Manual to check how many hours there are left of battery life on the xFOB.

Never attempt fast speed or dangerous maneuvers of the boat, especially if battery level is low on the xFOB. Battery depletion of xFOB can cause sudden engine stop and result in loss of control or maneuverability of the boat.

Never attempt any service of inside components in either the xHUB or the xFOB.



Voir [www.fellmarine.com/support](http://www.fellmarine.com/support) pour des informations importantes, consignes d'installation CEM, la garantie et exclusions en français.



Ver [www.fellmarine.com/support](http://www.fellmarine.com/support) para obtener información importante, pautas para la instalación de EMC la garantía y limitaciones de responsabilidad en Español.



Siehe [www.fellmarine.com/support](http://www.fellmarine.com/support) für wichtige Informationen, EMV-Installationsrichtlinien Gewährleistung und Haftungsausschlüsse in deutscher Sprache.

© FELL Technology AS, Nedre Storgate 46, N-3015, Drammen, Norway. FELL®, WIMEA®, WIMEA Protocol, MOB+, xHUB, xFOB, xTAG and its logos are trademarks of FELL Technology AS, its subsidiaries and affiliates. The shape and design of this product are a trademark of FELL Technology AS, subsidiaries and affiliates. NMEAB®, NMEA 2000®, and the NMEA 2000 logo are registered trademarks of the National Marine Electronics Association. All other trademarks or registered trademarks are the property of their respective owners. Designed in Norway. Made in China and Taiwan. All rights reserved. Product features, appearances and specifications may be subject to change without notice. Read all instructions carefully before use. Visit [www.fellmarine.com/support](http://www.fellmarine.com/support) for complete Owner's Manual. Please retain this information for future reference.

### Disclaimer

Always boat responsibly. Before starting, know your boat and waterway rules. Always follow your boat manufacturer's procedures of operation. Never overload the boat and be sure to wear your life jacket at all times. Check your boat for all required safety equipment and never operate a boat under the influence of alcohol. Check your local weather forecast before leaving the dock and always provide a float plan to your marina, member of your family or friend.

In no event shall FELL Technology AS and its subsidiaries and/or its suppliers, agents or affiliates be liable for any direct, indirect, punitive, incidental, special consequential damages, to property or life, whatsoever arising out of or connected with the improper installation, misuse, improper maintenance, self-repair, or tampering of our products.

### Other safety considerations

Small parts contained in your device and its accessories may present a choking hazard to small children. Personal medical devices, such as pacemakers, may be sensitive to magnetic and electromagnetic fields. Since this device contain magnets and emit electromagnetic fields, they should be kept at least 30 cm from any personal medical device. If any interference is observed, consult with your physician before resuming use. Items with magnetically-stored data, such as credit cards and hard drives, may also be sensitive to magnetic or electromagnetic fields, and should not be placed near this device.

### CE Declaration of Conformity

FELL equipment and accessories are designed to the best industry standards for use in the recreational marine environment. Their design and manufacture conforms to the appropriate Electromagnetic Compatibility (EMC) regulations, but correct installation is required to ensure that performance is not compromised. Please see section EMC Installation Guidelines in the User Manual for optimum EMC conditions. Products sold in the EU/CEEA is in accordance with the essential requirements and other relevant provisions of R&TE Directive 1990/269/EEC.

**Recycling:** In some areas, the disposal of certain electronic devices is regulated. Make sure you dispose of or recycle all FELL devices in accordance with your local laws and regulations.

**Patent notice:** The FELL devices and/or methods used in association with the FELL devices may be covered by one or more patents or pending patent applications.

### Warranty, Important Product- and Safety Information

Failure to avoid the following potentially hazardous situations could result in an accident or collision resulting in death or serious injury.

**Disclaimer:** By using this device you agree upon all the following guidelines and information provided in this document. Read all instructions carefully before using this device. Always boat responsibly. Before starting, know your boat and waterway rules. Always follow your boat manufacturer's procedures of operation. Never overload the boat and be sure to wear your life jacket at all times. Check your boat for all required safety equipment and never operate a boat under the influence of alcohol. Check your local weather forecast before leaving the dock and always provide a float plan to your marina, member of your family or friend. In no event shall FELL and its subsidiaries and/or its suppliers, agents or affiliates be liable for any direct, indirect, punitive, incidental, special consequential damages, to property or life, whatsoever arising out of or connected with the improper installation, use, misuse, improper maintenance, self-repair, or tampering of our products.

### Marine Operation Warnings

- You are responsible for the safe and prudent operation of your vessel. This device is a tool to enable you to enhance your safety while operating your vessel. It does not relieve you from the responsibility of safely operating your vessel. Avoid navigational hazards and never leave the helm unattended.
- Always drive the boat carefully and in accordance with local laws.
- Use this device only as a safety aid. This device does not replace the cord based kill switch, and should be used at your own discretion and responsibility, knowing that in the event that you fall in your vessel the system may not automatically shut down your engine.
- This device will shut down your engine and give an alarm signal when you are out of wireless range or falls into the water within 2 seconds. Within the wireless range this device will not shut down the engine automatically e.g. if you fall in your boat within the wireless range the engine will not stop automatically. In this event, you can shut down the engine by pressing the button on your MOB+ xFOB or on the MOB+ xHUB. Always check your wireless range before use. The wireless range may vary from 5 – 20 meters depending on the wireless environment surrounding your vessel.
- Make sure that the system is working properly before leaving the dock. Refer to the section Using MOB+ in the User Manual for instructions on how to use the system and information about normal system operations.
- Always make sure to check the battery level sign on the xHUB before operating your vessel. Confer with section Battery Indication in the User Manual to check how many hours there are left of battery life on the xFOB.
- Never attempt fast speed or dangerous maneuvers of the boat, especially if battery level is low on the xFOB. Battery depletion of xFOB can cause sudden engine stop and result in loss of control or maneuverability of the boat.
- Do not leave your xFOB in the boat unobserved, this to prevent easy theft of the boat if the ignition key is also situated in the vessel. Please refer to the engine manufacturer for information regarding ignition and starting procedure of the engine.

### Limited Warranty

This FELL product is warranted to be free from defects in materials or workmanship for two years from the date of purchase. Within this period, FELL will, at its sole option, repair or replace any components that fail in normal use. Such repairs or replacements will be made at no charge to the customer for parts or labor, provided that the customer shall be responsible for any transportation cost. This warranty does not apply to: (i) cosmetic change, such as scratches, nicks and dents; (ii) consumable parts, such as batteries, unless product damage has occurred due to the defect in materials or workmanship; (iii) damage caused by accident, abuse, misuse, water, flood, fire, or other acts of nature or external causes; (iv) damage caused by service performed by anyone who is not an authorized service provider of FELL, or (v) damage to a product that has been modified or altered without the written permission of FELL, or (vi) damage to a product that has been connected to power and/or data cables that are not supplied by FELL. In addition, FELL reserves the right to refuse warranty claims against products or services that are obtained and/or used in contravention of the laws of any country. Repairs have 180 day warranty. If the unit sent in is still under its original warranty, then the new warranty will be for the remainder of the original two year warranty, depending on which is longer. For specific instructions about how to obtain warranty service for your device, please contact FELL support. THE WARRANTIES AND REMEDIES CONTAINED HEREIN ARE EXCLUSIVE AND IN LIEU OF ALL OTHER WARRANTIES EXPRESS, IMPLIED, OR STATUTORY, INCLUDING ANY LIABILITY ARISING UNDER ANY WARRANTY OF MERCHANTABILITY OR FITNESS FOR A PARTICULAR PURPOSE, STATUTORY OR OTHERWISE. THIS WARRANTY GIVES YOU SPECIFIC LEGAL RIGHTS, WHICH MAY VARY FROM STATE/COUNTRY TO STATE/COUNTRY. IN NO EVENT SHALL FELL, ITS SHAREHOLDERS, BOARD OF DIRECTORS, OR EXECUTIVE LEADERS BE LIABLE FOR ANY INCIDENTAL, SPECIAL, INDIRECT, OR CONSEQUENTIAL DAMAGES, WHETHER RESULTING FROM THE USE, MISUSE, OR INABILITY TO USE THIS PRODUCT OR FROM DEFECTS IN THE PRODUCT. SOME STATES/COUNTRIES DO NOT ALLOW THE EXCLUSION OF INCIDENTAL OR CONSEQUENTIAL DAMAGES, SO THE ABOVE LIMITATIONS MAY NOT APPLY TO YOU. SOME JURISDICTIONS DO NOT ALLOW LIMITATIONS ON HOW LONG A STATUTORY OR IMPLIED WARRANTY LASTS. SO THE ABOVE LIMITATION MAY NOT APPLY TO YOU. This limited warranty gives you specific rights. You may have additional rights under applicable law, and this limited warranty does not affect such rights. FELL retains the exclusive right to repair or replace (with a new or newly-overhauled replacement product) the device or software or offer a full refund of the purchase price at its sole discretion. SUCH REMEDY SHALL BE YOUR SOLE EXCLUSIVE REMEDY FOR ANY BREACH OF WARRANTY. To obtain warranty service, contact your local FELL authorized dealer or call FELL Support for shipping instructions and an Return Ticket Number. Securely pack the device and a copy of the original sales receipt, which is required as the proof of purchase for warranty repairs. Write the tracking number clearly on the outside of the package. Send the device, freight charges prepaid, to your nearest FELL address. See [www.fellmarine.com](http://www.fellmarine.com) to find your nearest address for return or contact your local FELL dealer. ONLINE AUCTION PURCHASES: Products purchased through online auctions are not eligible for rebates or other special offers from FELL warranty coverage. Online auction confirmations are not accepted for warranty verification. To obtain warranty service, an original or copy of the sales receipt from the original retailer is required. FELL will not replace missing components from any package purchased through an online auction.

**FOR INTERNATIONAL PURCHASES:** A separate warranty may be provided by international distributors for devices purchased outside Norway or the United States depending on country. If applicable, this warranty is provided by the local in-country distributor and this distributor provides local service for your device. Distributor warranties are only valid in the area of intended distribution.

**FOR AUSTRALIAN CONSUMERS:** Our goods come with guarantees that cannot be excluded under the Australian Consumer Law. You are entitled to a replacement or refund for a major failure and for compensation for any other reasonably foreseeable loss or damage. You are also entitled to have the goods repaired or replaced if the goods fail to be of acceptable quality and the failure does not amount to a major failure. Goods presented for repair may be replaced by refurbished goods of the same type rather than being repaired. Refurbished parts may be used to repair the goods.

Warranty provider  
FELL Technology AS Nedre Storgate 46, N-3015 Drammen, Norway  
Org.No: 912 282 554 - Website: [www.fellmarine.com](http://www.fellmarine.com)  
Tel: +47 32 82 82 80

Support: [support@fellmarine.com](mailto:support@fellmarine.com)  
Additional information  
[www.fellmarine.com](http://www.fellmarine.com)  
[www.fellmarine.com/support](http://www.fellmarine.com/support)

**MOB+ MULTI ENGINE HARNESS**

This product is designed to be used in conjunction with the MOB+ xHUB to stop up to three engines simultaneously for multiple outboard installations. The MOB+ xHUB should be installed prior to installation of this Multi Engine Harness.

TECHNICAL SPECIFICATION - MULTI ENGINE HARNESS	
<b>Measurements and performance</b>	
Weight	0,7oz. / 20g
Wires	18AWG / -0,8mm <sup>2</sup> , Tinned
Voltage Max	1kV
Amp. Rating	1A
Dimensions (including wires)	14,7 x 0,7 x 0,35 in / 360 x 18 x 9mm
Temperature Range	From 5°F / -15°C to 131°F / 55°C
<b>Certifications and compliance</b>	
ABYC A-33 compliant	<input checked="" type="checkbox"/>
RoHS (2002/95/EC) compliant materials	<input checked="" type="checkbox"/>
Safety	IEC 60950, CE-UL94

**SUPPORT**

**WATCH VIDEOS!**  
On [www.fellmarine.com/videos](http://www.fellmarine.com/videos) you will find installation and user guide videos.

**WE ARE HERE TO HELP YOU**  
Please feel free to contact us with any inquiry.  
Customer care: [www.fellmarine.com/customer-care](http://www.fellmarine.com/customer-care)  
Business hours: Monday-Friday 08:00am – 04:00pm  
Email: [support@fellmarine.com](mailto:support@fellmarine.com)  
Web support: [www.fellmarine.com/support/](http://www.fellmarine.com/support/)  
Social Media: [facebook.com/fellmarine](https://www.facebook.com/fellmarine)  
Web: [www.fellmarine.com](http://www.fellmarine.com)

Product category: Marine electronics

**WARNING: CHOKING HAZARD**  
Small parts. Not for children under 3 years

Norway  
FELL Technology AS  
Nedre Storgate 46  
N-3015, Drammen  
[www.fellmarine.com](http://www.fellmarine.com)  
[mail@fellmarine.com](mailto:mail@fellmarine.com)

Designed in Norway. Printed in China

Part name: MOB+ Multi Engine Harness  
P/N: (F-A/N): 72.380.401  
Availability: FELL Marine dealers and [buy.fellmarine.com](http://buy.fellmarine.com)

# INSTALLATION

## WIRING DIAGRAM

### TO BE USED ON OUTBOARD ENGINES ONLY

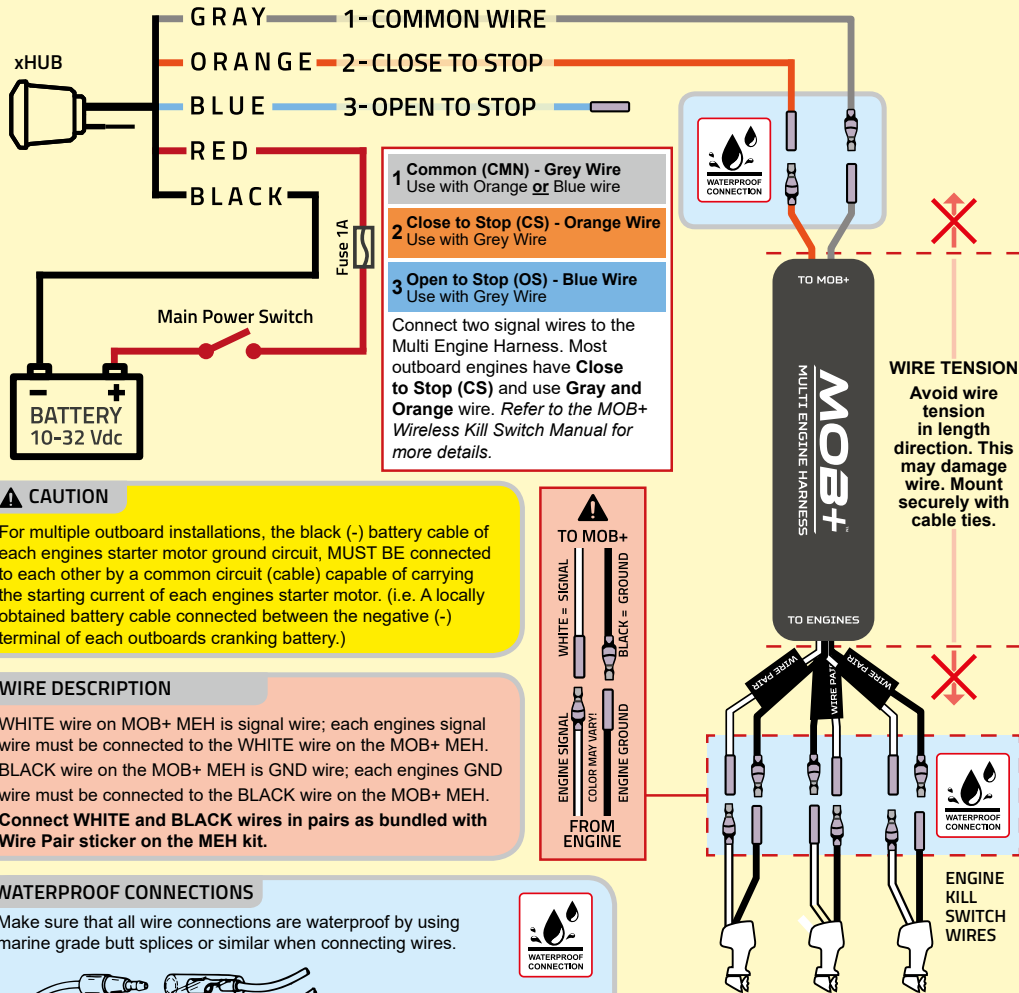

### CAUTION

For multiple outboard installations, the black (-) battery cable of each engines starter motor ground circuit, **MUST BE** connected to each other by a common circuit (cable) capable of carrying the starting current of each engines starter motor. (i.e. A locally obtained battery cable connected between the negative (-) terminal of each outboards cranking battery.)

### WIRE DESCRIPTION

WHITE wire on MOB+ MEH is signal wire; each engines signal wire must be connected to the WHITE wire on the MOB+ MEH. BLACK wire on the MOB+ MEH is GND wire; each engines GND wire must be connected to the BLACK wire on the MOB+ MEH. **Connect WHITE and BLACK wires in pairs as bundled with Wire Pair sticker on the MEH kit.**

### WATERPROOF CONNECTIONS

Make sure that all wire connections are waterproof by using marine grade butt splices or similar when connecting wires.

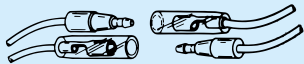

Splice Wire Dimension: 20-16 AWG / 0.5 - 1.5 mm<sup>2</sup>

**!** When used on two outboard engines only. Connect two of the three wire pairs to your two engines. Attach the included closed end terminals to the wire pair not used.

# VERIFY INSTALLATION

## PAIRING AND CONNECTING

**1** After proper installation, pair the xFOB and the xHUB as described below. The xHUB remembers the 20 last paired xFOBs. Pairing saves the ID of xFOBs in the memory of the xHUB. Pairing is only done the first time you use an xFOB with an xHUB.



### HOLD 3 SEC

Pairing is only necessary the first time you use your MOB+™. Press and hold the button on your xHUB™.



### BLUE LIGHT

Release the button when the xHUB™ starts flashing blue and gives a sound signal indicating Pairing Mode.



### HOLD 3 SEC

Immediately after releasing the button on the xHUB™, press and hold the button on your xFOB™.



### GREEN LIGHT

The xHUB™ will give a sound signal and a green light to indicate a successful pairing.



### CONNECT

Click the button on your xFOB to connect.



### CONNECTED

The xHUB™ will give a sound signal and a green light to indicate a successful connection.

## IMPORTANT

**!** We recommend that the installation of the MOB+ in your boat is performed by skilled personnel familiar with electric wiring, or by a professional mechanic or electrician. This is to prevent any malfunction of the device related to installation.

## SYSTEM TEST

**2** After installation, test the system as described below to ensure installation is done correctly. Always make sure the system is working properly before operating your vessel.



### CONNECT

Click the button on your xFOB to connect.



The xHUB™ will give a sound signal and a GREEN light to indicate a successful connection.



### START ENGINES

Start your engines.



### TEST THE MOB+

Test the MOB+ by disconnecting with the xFOB or by submerging the xFOB.

Both described methods are equal in terms of testing stop functionality.



### DISCONNECT

Click the xFOB to stop the engines -The system will now shut down the engines and disconnect the wireless system.

RECONNECT AND RESTART THE ENGINES BEFORE TESTING SUBMERSION



### SUBMERSION

Submerge the xFOB in the sea or the ocean more than 4 inches / 10cm. -The system will now go into Man Over Board mode and shut down the engine. After 6 seconds the xHUB will go into override mode. Press the xHUB or xFOB to disconnect the wireless system.

**!** A bucket of water is not sufficient to test the functionality of MOB+. Test the system in the sea or ocean/lake.