

Quick®

CE REV 009B

High Quality Nautical Equipment

ARIES FLAIR RIDER 700/1000/1400W

A 712	A 712 D
A 724	A 724 D
A 1012	A 1012 D
A 1024	A 1024 D
A 1412	A 1412 D
A 1424	A 1424 D
F 712	F 712 D
F 724	F 724 D
F 1012	F 1012 D
F 1024	F 1024 D
F 1412	F 1412 D
F 1424	F 1424 D
R 712	R 712 D
R 724	R 724 D
R 1012	R 1012 D
R 1024	R 1024 D
R 1412	R 1412 D
R 1424	R 1424 D

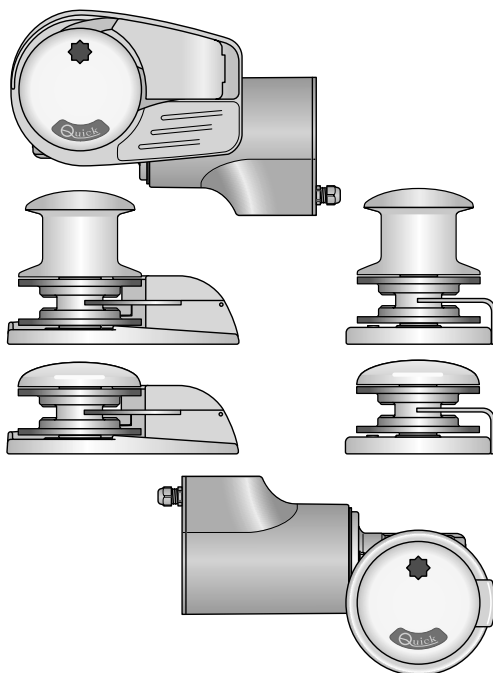

IT	Manuale d'uso
GB	User's Manual
FR	Manuel de l'utilisateur
DE	Benutzerhandbuch
ES	Manual del usuario

SALPA ANCORA VERTICALI
VERTICAL WINDLASSES
GUINDEAUX VERTICAUX
VERTIKAL ANKERWINDEN
MOLINETES VERTICALES



IT INDICE

Pag. 4	Caratteristiche tecniche	Pag. 7	Usò - Avvertenze importanti
Pag. 5	Installazione	Pag. 8/9	Manutenzione
Pag. 6	Schema di collegamento	Pag. 10/11	Set

GB INDEX

Pag. 12	Technical data	Pag. 15	Usage - Warning
Pag. 13	Installation	Pag. 16/17	Maintenance
Pag. 14	Connection diagram	Pag. 18/19	Set

FR SOMMAIRE

Pag. 20	Caractéristiques techniques	Pag. 23	Utilisation - Avvertissements importants
Pag. 21	Installation	Pag. 24/25	Entretien
Pag. 22	Schéma de câblage	Pag. 26/27	Groupe

DE INHALTSANGABE

Seite 28	Technische Eigenschaften	Seite 31	Gebrauch - Wichtige Hinweise
Seite 29	Montage	Seite 32/33	Wartung
Seite 30	Anschlussplan	Seite 34/35	Gruppe

ES INDICE

Pág. 36	Características técnicas	Pág. 39	Usò - Advertencias importantes
Pág. 37	Instalación	Pág. 40/41	Mantenimiento
Pág. 38	Esquema de montaje	Pág. 42/43	Grupo



IT

CARATTERISTICHE TECNICHE

COME SI LEGGE IL MODELLO DEL SALPA ANCORA:

1° ESEMPIO: FLAIR724D

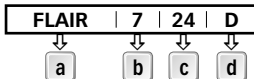

2° ESEMPIO: RIDER1012

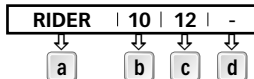

a

Nome della serie:

[ARIES] = base ovale in alluminio
 [FLAIR B] = base ovale in fibra nera
 [FLAIR W] = base ovale in fibra bianca
 [RIDER] = base circolare in alluminio

b

Potenza motore:

[7] = 700 W
 [10] = 1000 W
 [14] = 1400 W

c

Tensione alimentazione motore:

[12] = 12 V
 [24] = 24 V

d

Campana:

[D] = con campana
 [-] = senza campana

MODELLO	ARIES - / D						FLAIR - / D						RIDER - / D										
	W	700		1000		1400		W	700		1000		1400		W	700		1000		1400			
Tensione motore	V	12	24	12	24	12	24	12	24	12	24	12	24	12	24	12	24	12	24	12	24		
Tiro istantaneo massimo	kg	850		1000		1100		850	1000		1100		850	1000		1100		850	1000		1100		
	lb	1874		2205		2425		1874	2205		2425		1874	2205		2425		1874	2205		2425		
Carico di lavoro massimo	kg	250	300	370	450	450	500	250	300	370	450	450	500	250	300	370	450	450	500	250	300	370	450
	lb	551	661	815	992	992	1100	551	661	815	992	992	1100	551	661	815	992	992	1100	551	661	815	992
Carico di lavoro	kg	80	100	120	150	150	170	80	100	120	150	150	170	80	100	120	150	150	170	80	100	120	150
	lb	176	220	264.5	330.7	330.7	374.8	176	220	264.5	330.7	330.7	374.8	176	220	264.5	330.7	330.7	374.8	176	220	264.5	330.7
Assorbimento corrente al carico di lavoro (1)	A	90	55	140	80	155	85	90	55	140	80	155	85	90	55	140	80	155	85	90	55	140	80
Velocità max di recupero (2)	m/min	27.4	26.4	39.6	40.9	33.0	29.7	27.4	26.4	39.6	40.9	33.0	29.7	27.4	26.4	39.6	40.9	33.0	29.7	27.4	26.4	39.6	40.9
	ft/min	90.0	86.6	130.0	134.2	108.0	97.4	90.0	86.6	130.0	134.2	108.0	97.4	90.0	86.6	130.0	134.2	108.0	97.4	90.0	86.6	130.0	134.2
Velocità di recupero al carico di lavoro (2)	m/min	14.4	14.8	20.4	21.4	17.5	20.5	14.4	14.8	20.4	21.4	17.5	20.5	14.4	14.8	20.4	21.4	17.5	20.5	14.4	14.8	20.4	21.4
	ft/min	47.2	48.6	67.0	70.2	57.4	67.2	47.2	48.6	67.0	70.2	57.4	67.2	47.2	48.6	67.0	70.2	57.4	67.2	47.2	48.6	67.0	70.2
Sezione minima cavi motore (3)	mm ²	25	10	35	16	50	25	25	10	35	16	50	25	25	10	35	16	50	25	25	10	35	16
	AWG	3	7	2	5	0	3	3	7	2	5	0	3	3	7	2	5	0	3	3	7	2	5
Interruttore di protezione (4)	A	50	40	80	50	100	50	50	40	80	50	100	50	50	40	80	50	100	50	50	40	80	50
Peso modello senza campana	kg	17.4		18.5		20.8		16.5	17.6		19.9		16.0	17.1		19.4		16.5	17.6		19.9		
	lb	38.4		40.8		45.9		36.4	38.8		43.9		35.3	37.7		42.8		36.4	38.8		43.9		
Peso modello con campana	kg	19.3		20.4		22.7		22.7	18.4		19.5		18.0	19.1		21.4		22.7	18.4		19.5		
	lb	42.6		45.0		50.0		40.6	43.0		48.1		40.6	43.0		48.1		40.6	43.0		48.1		

- (1) Dopo un primo periodo d'uso.
- (2) Misure effettuate con barbotin per catena da 8 mm.
- (3) Valore minimo consigliato per una lunghezza totale L<20m (Vedi pag. 44). Calcolare la sezione in funzione della lunghezza del collegamento.
- (4) Con interruttore specifico per correnti continue (DC) e ritardato (magneto-termico o magneto-idraulico).

BARBOTIN (*)	6mm	8mm - 5/16"	10mm - 3/8"
Catena supportata	DIN 766 / ISO (**)	DIN 766 / ISO (**)/ G4 / BBB	DIN 766 / ISO (**)/ G4

- (*) Per i codici dei barbotin fare riferimento all'esplosivo a pag 8.
- (**) ISO EN 818-3.

DIMENSIONI mm (inch)	ARIES/FLAIR - / D		RIDER - / D		ARIES/FLAIR - / D	RIDER - / D
	700W	1000W	700W	1000W	1400W	
A	98 (3" 27/32)		100 (3" 15/16)		98 (3" 27/32)	100 (3" 15/16)
B	164 (6" 7/16)		166 (6" 17/32)		164 (6" 7/16)	166 (6" 17/32)
C	141 (5" 9/16)		179 (7")		179 (7")	
D	250 (9" 27/32)		159 (6" 1/4)		250 (9" 27/32)	159 (6" 1/4)
E	141 (5" 9/16)		141 (5" 9/16)		141 (5" 9/16)	
F	87 (3" 7/16)		0 155 (6" 3/32)		87 (3" 7/16)	0 155 (6" 3/32)
G	78 (3" 23/32)		-		78 (3" 23/32)	-
H	330 (13")	340 (13" 3/8)	330 (13")	340 (13" 3/8)	385 (15" 1/8)	
I	25 + 50 mm (31/32" + 1" 31/32") (5)				30 + 50 mm (1" 3/32 + 1" 31/32") (5)	

- (5) Si richiasta possono essere forniti alberi e prigionieri per spessori di coperta maggiori.

700 / 1000 / 1400 W ARIES - FLAIR - / D

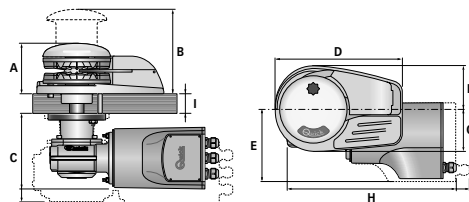

700 / 1000 / 1400 W RIDER - / D

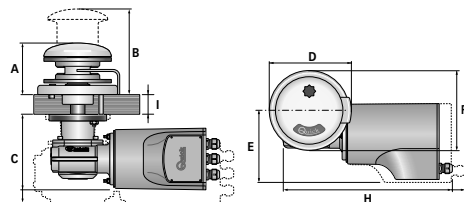

Quick® si riserva il diritto di apportare modifiche alle caratteristiche tecniche dell'apparecchio e al contenuto di questo manuale senza alcun preavviso. In caso di discordanze o eventuali errori tra il testo tradotto e quello originario in italiano, fare riferimento al testo italiano o inglese.



PRIMA DI UTILIZZARE IL SALPA ANCORA LEGGERE ATTENTAMENTE IL PRESENTE MANUALE D'USO. IN CASO DI DUBBI CONSULTARE IL RIVENDITORE QUICK®.

- ⚠ **ATTENZIONE:** i salpa ancora Quick® sono stati progettati e realizzati per salpare l'ancora. ⚠ Non utilizzare questi apparecchi per altri tipi di operazioni. ⚠ Quick® non si assume alcuna responsabilità per i danni diretti o indiretti causati da un uso improprio dell'apparecchio. ⚠ Il salpa ancora non è progettato per sostenere carichi generati in particolari condizioni atmosferiche (burrasca). ⚠ Disattivare sempre il salpa ancora quando non è in uso.
- ⚠ Accertarsi che non vi siano bagnanti nelle vicinanze prima di calare l'ancora. ⚠ La giunzione tra la cima e la catena deve avere dimensioni ridotte per poter scorrere agevolmente dentro la sagoma del barbotin. Per qualsiasi problema o richiesta contattare l'assistenza Quick®. ⚠ Per maggiore sicurezza, nel caso in cui uno si danneggi suggeriamo di installare almeno due comandi per l'azionamento del salpa ancora. ⚠ Consigliamo l'uso dell'interruttore magneto-idraulico Quick® come sicurezza per il motore. ⚠ Bloccare la catena con un fermo prima di partire per la navigazione.
- ⚠ La scatola teleruttori o teleinvertitori deve essere installata in un luogo protetto da possibili entrate d'acqua.

LA CONFEZIONE CONTIENE: salpa ancora (top + motoriduttore) - cassetta teleruttori - guarnizione della base - dima di foratura - leva - viterie (per l'assemblaggio) - manuale di istruzioni - condizioni di garanzia.

ATTREZZI NECESSARI PER L'INSTALLAZIONE: trapano con punte: $\varnothing 9 \text{ mm}$ (23/64") e $\varnothing 11 \text{ mm}$ (7/16"); a tazza $\varnothing 53 \text{ mm}$ (2"1/16) e $\varnothing 70 \text{ mm}$ (2"3/4); chiave esagonale: 13 mm.

ACCESSORI QUICK® CONSIGLIATI: deviatore da pannello (mod. 800) - Pulsantiera stagna (mod. HRC 1002) - Pulsante a piede (mod. 900) - Interruttore magneto-idraulico - Conta catena per l'ancoraggio (mod. CHC 1102M e CHC 1202M) - Sistema di comando via radio (mod. 1302,1352; 02, 302).

REQUISITI PER L'INSTALLAZIONE: il salpa ancora va posizionato allineando il barbotin con il puntale di prua. Verificare che le superfici superiore e inferiore della coperta siano più parallele possibili; se ciò non dovesse accadere compensare opportunamente la differenza (la mancanza di parallelismo potrebbe causare perdite di potenza del motore). Lo spessore di coperta dovrà essere compreso fra i valori indicati in tabella. Se si avessero spessori differenti è necessario consultare il rivenditore Quick®. Non devono esistere ostacoli sotto coperta per il passaggio di cavi, cima e catena, la poca profondità del gavone potrebbe provocare inceppamenti.

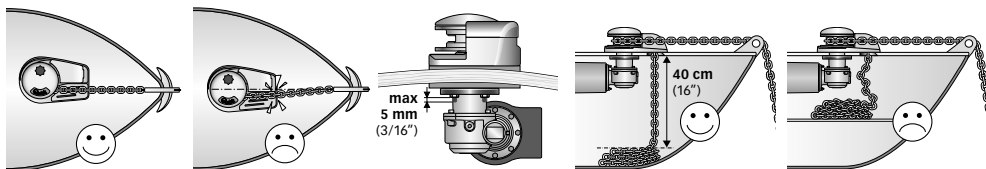

PROCEDURA DI MONTAGGIO: stabilita la posizione ideale praticare i fori utilizzando la dima di foratura fornita a corredo. Rimuovere il materiale in eccesso dal foro di passaggio della catena/cima, rifinirlo e lisciarlo con un prodotto specifico (vernice marittima, gel o resina epossidica) assicurando il libero passaggio della catena/cima. Posizionare la parte superiore, inserendo la guarnizione fra la coperta e la base e collegare a questa la parte inferiore, infilando l'albero nel riduttore. Fissare il salpa ancora avvitando i dadi sui prigionieri di bloccaggio. Collegare i cavi di alimentazione provenienti dal salpa ancora al teleruttore.

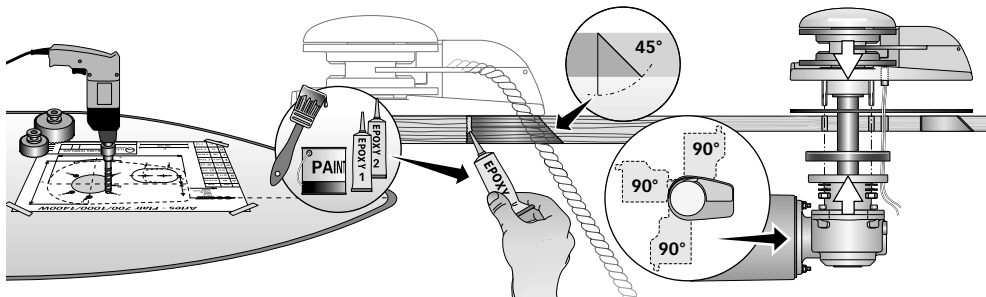

- ⚠ **ATTENZIONE:** prima di effettuare il collegamento accertarsi che non sia presente l'alimentazione su cavi.





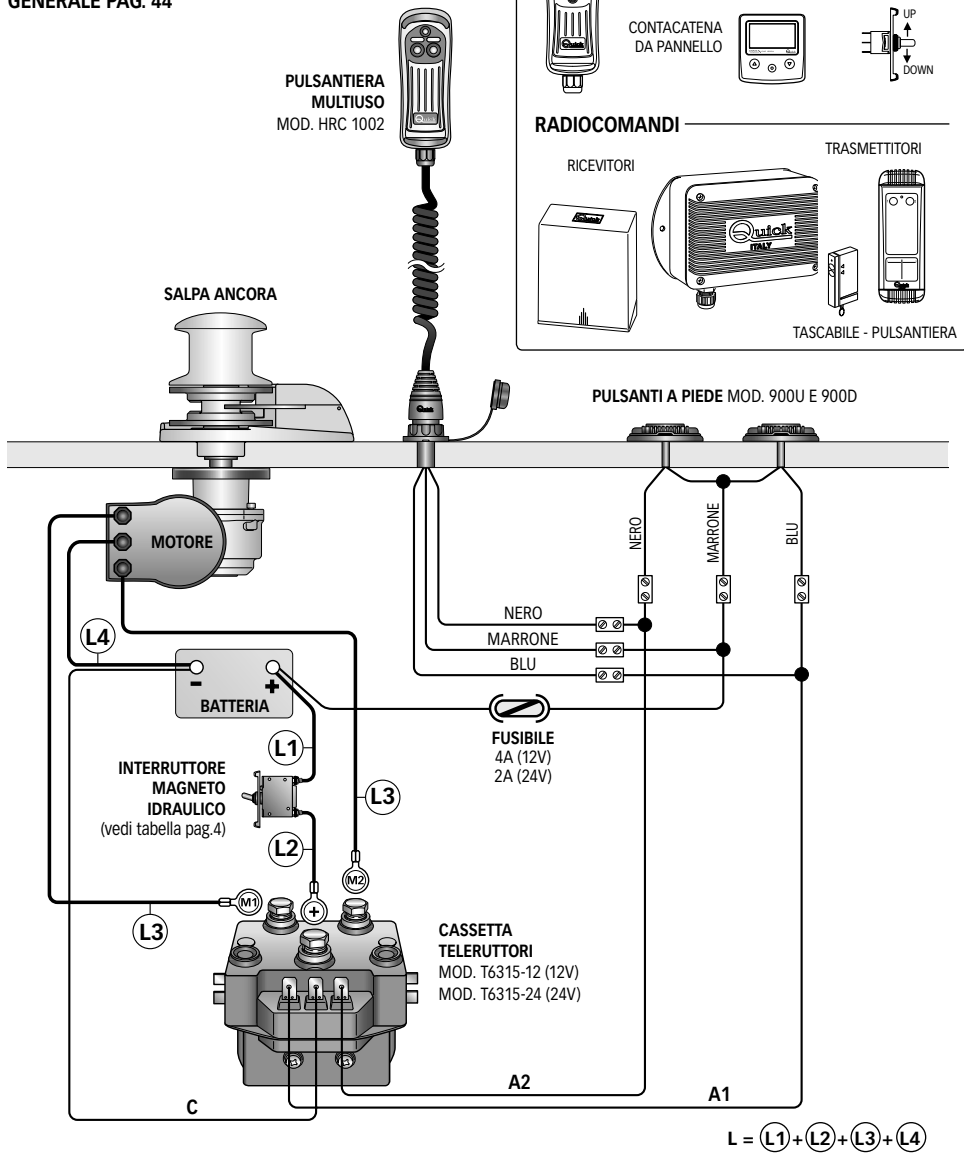

SISTEMA BASE

SCHEMA DI COLLEGAMENTO
GENERALE PAG. 44



AVVERTENZE IMPORTANTI

-  **ATTENZIONE:** non avvicinare parti del corpo o oggetti alla zona in cui scorrono catena, cima e barbotin. Accertarsi che non sia presente l'alimentazione al motore elettrico quando si opera manualmente sul salpa ancora (anche quando si utilizza la leva per allentare la frizione); infatti persone dotate di comando a distanza del salpa ancora (pulsantiera remota o radiocomando) potrebbero accidentalmente attivarlo.
-  **ATTENZIONE:** bloccare la catena con un fermo prima di partire per la navigazione.
-  **ATTENZIONE:** non attivare elettricamente il salpa ancora con la leva inserita nella campana o nel coperchio del barbotin.
-  **ATTENZIONE:** Quick® consiglia di utilizzare un interruttore specifico per correnti continue (DC) e ritardato (magneto termico o magneto idraulico) per proteggere la linea del motore da surriscaldamenti o cortocircuiti. L'interruttore può essere utilizzato per isolare il circuito di comando del salpa ancora evitando così azionamenti accidentali.

USO DELLA FRIZIONE

Il barbotin (6) è reso solidale all'albero principale (13 o 14) dalla frizione (5). La frizione si apre (stacco) utilizzando la leva (1) che inserita nella bussola della campana o coperchio barbotin (3 o 2) dovrà ruotare in senso antiorario. Ruotando in senso orario si provocherà la chiusura (attacco) della frizione.

PER SALPARE

Accendere il motore dell'imbarcazione. Assicurarsi che la frizione (5) sia serrata ed estrarre la leva (1).

Premere il pulsante UP del comando a vostra disposizione.

Se il salpa ancora si arresta senza che l'interruttore magneto-idraulico (o magnetotermico) sia scattato, attendere qualche secondo e riprovare (evitare una pressione continuata del pulsante).

Se l'interruttore magneto-idraulico (o magnetotermico) è scattato, riattivare l'interruttore e attendere qualche minuto prima di riprendere a salpare.

Se, dopo ripetuti tentativi, il salpa ancora continua a bloccarsi consigliamo di manovrare l'imbarcazione per disincagliare l'ancora.

Controllare la salita degli ultimi metri di catena per evitare danni alla prua.

PER CALARE

La calata dell'ancora si può effettuare tramite comandi elettrici oppure manualmente. Per effettuare l'operazione manualmente occorre aprire la frizione (5) lasciando libero il barbotin (6) di girare sul proprio asse e trascinare la catena o la cima in acqua.

Per frenare la caduta dell'ancora bisogna ruotare la leva (1) in senso orario.

Per calare l'ancora elettricamente occorre premere il pulsante DOWN del comando a vostra disposizione. In questo modo la calata è perfettamente controllabile e lo svolgimento della catena o della cima è regolare.

Per evitare sollecitazioni sul salpa ancora, una volta ancorati, bloccare la catena con un fermo oppure fissarla ad un punto saldo con una cima.



POS.	DENOMINAZIONE	CODICE
1A	Leva 700-1000W	MSHD00000000
1B	Leva 1400W	ZSLMSH000000
2	Coperchio barbotin	MSGB10000R01
3	Bussola	MSD10000R01
4	Campana	ZSGMSE100000
5	Cono frizione	MSF100000000
6A	Barbotin 6 mm	ZSB100600000
6B	Barbotin 8 mm-5/16"	ZSB1008516R4
6C	Barbotin 10 mm-3/8"	ZSB1010380AR
7	Magnete	KPMC08060000
8	Rondella sagomata	MBR254025X00
9	Paraolio	PGPRL2547700
10	Anello elastico interno	MBAN4717Y000
11	Anello elastico esterno	MBAE2520Y000

POS.	DENOMINAZIONE	CODICE
12	Cuscinetto	MBJ60052RS10
13	Albero corto	MSAS10274R30
14	Albero lungo	MSAS10308R30
15	Chiavetta	MBH080780F00
16A	Coperchio guida catena A	SGMSGG100000
16B	Coperchio guida catena F bianca	PDGC10DW0000
16C	Coperchio guida catena F nera	PDGC10DB0000

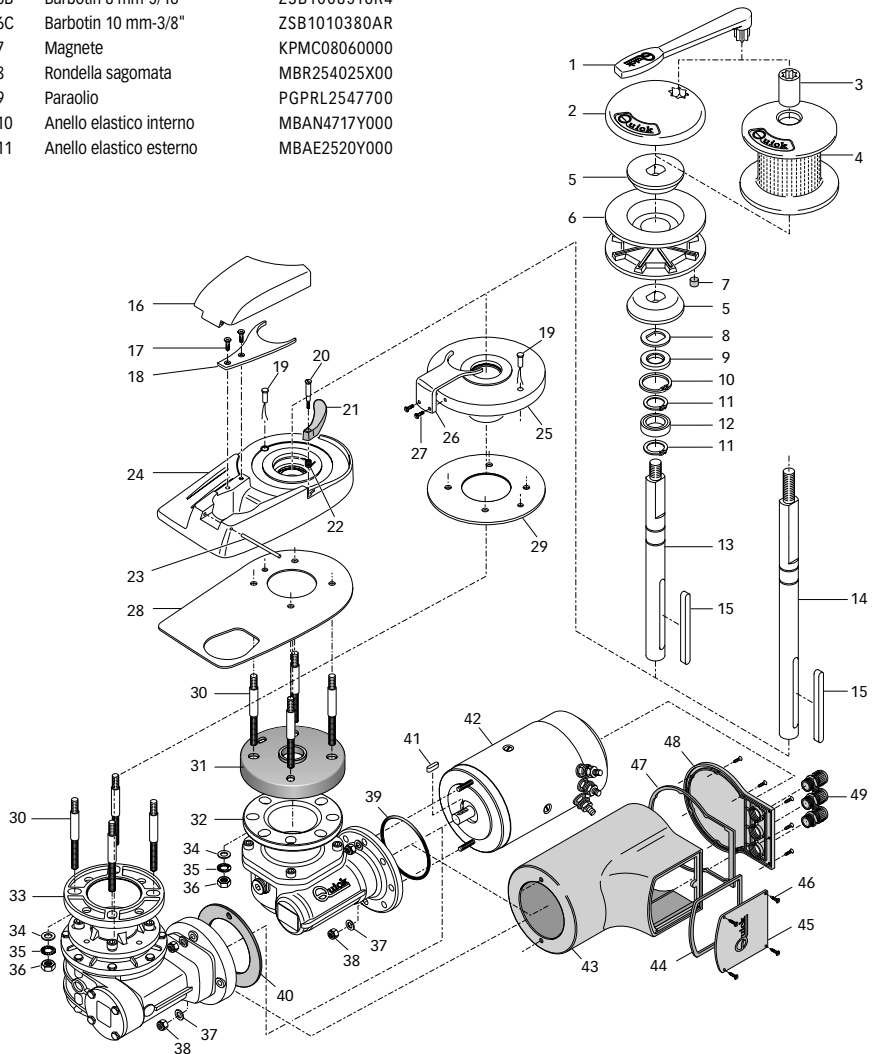



POS.	DENOMINAZIONE	CODICE
17A	Vite per base Aries	MBV0516MXSC0
17B	Vite per base Flair	MBV0530MXSC0
18A	Stacca catena per base Aries	MSN10VXP0000
18B	Stacca catena per base Flair	MSN10VXD0000
19	Sensore	SAKREED00000
20	Vite tendicima	MSMVT1000000
21A	Leva tendicima nera	PDLVTD100000
21B	Leva tendicima bianca	PDLVTD10W000
22	Molla tendicima	MMTND1000000
23	Spina coperchio	MSR10X000000
24A	Base ovale Aries	SGMSC10V0000
24B	Base ovale Flair bianca	SMPD10VW0000
24C	Base ovale Flair nera	SMPD10VB0000
25	Base circolare	SGMSC10C0000
26	Stacca catena per base Rider	MSN10CX00000
27	Vite per base Rider	MBV0620MXSC0
28	Guarnizione/dima Aries-Flair	PGBSV1000000
29	Guarnizione/dima Rider	PGBSC1000000
30A	Prigionieri base Aries	MBP080807X00
30B	Prigionieri base Flair	MBP080808X00
31	Guarnizione flangia riduttore Top TG50	PGFLRDTG5000
32	Riduttore 700/1000W Quick TG50	SLMR10TG5000
33	Riduttore 1400W	MR1400000000
34	Rondella	MBR08X000000
35	Rondella dentellata	MBR08XDE0000
36	Dado	MBD08MXEN000
37	Rondella	MBR061815X00
38	Dado autobloccante	MBD06MXET000
39	O-ring	-
40	Guarnizione motoriduttore	PGNP10000000
41	Chiavetta	MBH050515F00
42A	Motore 700W 12V	EMF071200000
42B	Motore 700W 24V	EMF072400000
42C	Motore 1000W 12V	EMF101200000
42D	Motore 1000W 24V	EMF102400000
42E	Motore 1400W 12V	EMF141200000
42F	Motore 1400W 24V	EMF142400000
43A	Carter 700W	PCCCPM070000
43B	Carter 1000/1400W	PCCCPM100000
44	Guarnizione morsettiere 700/1000/1400W	PCGPMMR00000
45	Coperchio morsettiere 700/1000/1400W	PCCPPMMR0000
46	Vite	MBV02213AXSC
47	Guarnizione fondo 700/1000/1400W	PGGPMFN00000
48	Coperchio fondo 700/1000/1400W	PCCPPMFN0000
49	Passacavo	PPM20B000000



ATTENZIONE: accertarsi che non sia presente l'alimentazione al motore elettrico quando si opera manualmente sul salpa ancora; rimuovere con cura la catena o cima dal barbotin o la cima dalla campana.

I salpa ancora Quick® sono costituiti da materiali resistenti all'ambiente marino: è indispensabile, in ogni caso, rimuovere periodicamente i depositi di sale che si formano sulle superfici esterne per evitare corrosioni e di conseguenza danni all'apparecchio.

Lavare accuratamente con acqua dolce le superfici e le parti in cui il sale può depositarsi.

Smontare una volta all'anno il barbotin e la campana attenendosi alla seguente sequenza:

VERSIONE CON CAMPANA

Con la leva (1) svitare la bussola (3); estrarre la campana (4) e il cono frizione superiore (5); svitare le viti di fissaggio (17 o 27) dello stacca catena (18 o 26) e rimuoverlo; estrarre il barbotin (6).

VERSIONE SENZA CAMPANA

Con la leva (1) svitare il coperchio barbotin (6); estrarre il cono frizione superiore (5); svitare le viti di fissaggio (17 o 27) dello stacca catena (18 o 26) e rimuoverlo; estrarre il barbotin (6).

Pulire ogni parte smontata affinché non si verifichino attacchi di corrosione e ingrassare (con grasso marino) il filetto dell'albero (13 o 14) e il barbotin (5) dove appoggiano i coni frizione (5).

Ingrassare periodicamente il perno (23) del coperchio guida catena (16) (solamente per salpa ancora con base in alluminio).

Rimuovere eventuali depositi di ossido sui morsetti della cassetta teleruttori; cospargerli di grasso.

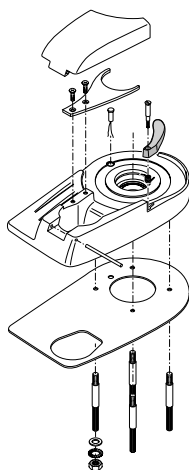
**BASE COMPLETA - ARIES/FLAIR**

Base salpa 700/1000/1400W "ARIES"

Base salpa 700/1000/1400W "FLAIR BLACK"

Base salpa 700/1000/1400W "FLAIR WHITE"

CODICE

ZSBSA010C000

ZSBSFB10C000

ZSBSFW10C000

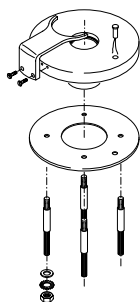
**BASE COMPLETA - RIDER**

Base salpa 700/1000/1400W "RIDER"

CODICE

ZSBSR010C000

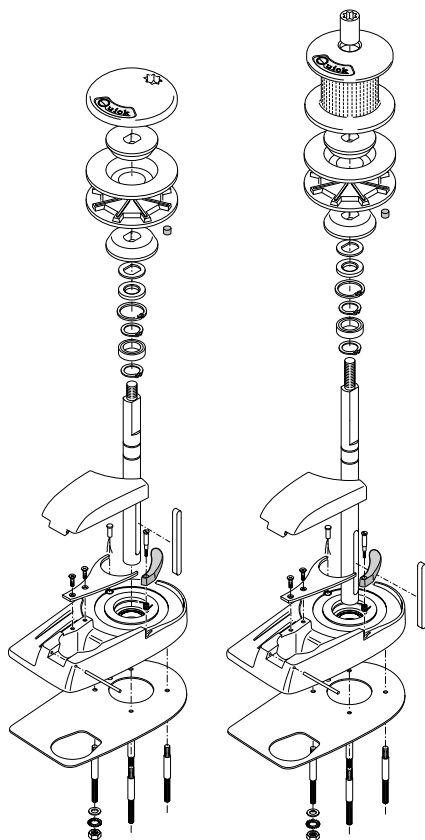
**TOP SENZA CAMPANA - ARIES/FLAIR**

Top serie A 7/10/1400W 6 mm

Top serie A 7/10/1400W 8 mm-5/16"

Top serie A 7/10/1400W 10 mm-3/8"

Top serie F Black 7/10/1400W 6 mm

Top serie F Black 7/10/1400W 8 mm-5/16"

Top serie F White 7/10/1400W 6 mm

Top serie F White 7/10/1400W 8 mm-5/16"

CODICE

ZSTA01000600

ZSTA01000851

ZSTA01001038

ZSTFB1000600

ZSTFB1000851

ZSTFW1000600

ZSTFW1000851

TOP CON CAMPANA - ARIES/FLAIR

Top serie A 7/10/1400W 6mm D

Top serie A 7/10/1400W 8 mm-5/16" D

Top serie A 7/10/1400W 10 mm-3/8" D

Top serie F Black 7/10/1400W 6 mm D

Top serie F Black 7/10/1400W 8 mm-5/16" D

Top serie F White 7/10/1400W 6 mm D

Top serie F White 7/10/1400W 8 mm-5/16" D

ZSTA010D0600

ZSTA010D0851

ZSTA010D1038

ZSTFB10D0600

ZSTFB10D0851

ZSTFW10D0600

ZSTFW10D0851

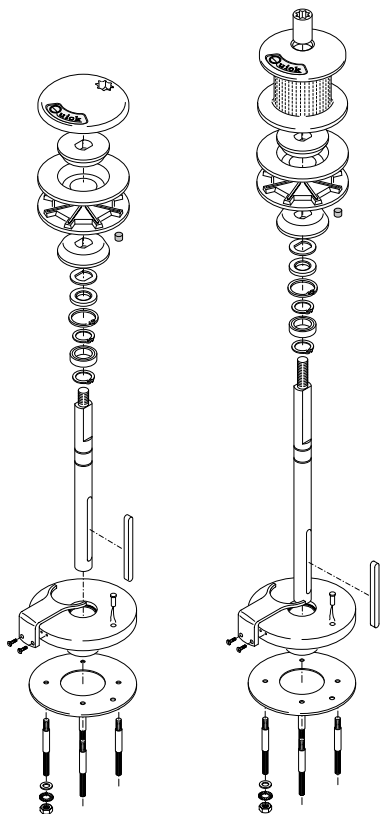
**TOP SENZA CAMPANA - RIDER**

Top serie R 7/10/1400W 6 mm

Top serie R 7/10/1400W 8 mm-5/16"

Top serie R 7/10/1400W 10 mm-3/8"

TOP CON CAMPANA - RIDER

Top serie R 7/10/1400W 6 mm D

Top serie R 7/10/1400W 8 mm-5/16" D

Top serie R 7/10/1400W 10 mm-3/8" D

CODICE

ZSTR01000600

ZSTR01000851

ZSTR01001038

ZSTR010D0600

ZSTR010D0851

ZSTR010D1038

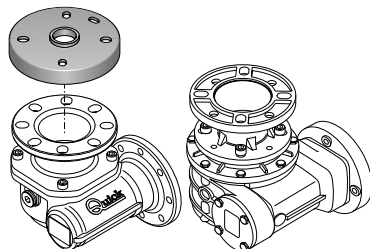
**RIDUTTORE - ARIES FLAIR RIDER**

Riduttore 700/1000W - serie Quick TG50

Riduttore 1400W

CODICE

SLMR10TG5000

MR1400000000

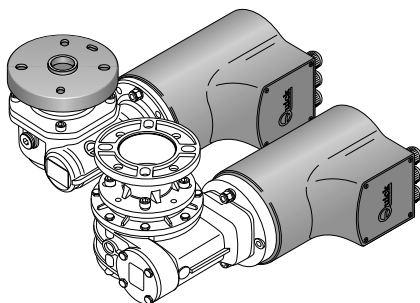
**MOTORIDUTTORE - ARIES FLAIR RIDER**

Motoriduttore 700W 12V - Quick

Motoriduttore 1000W 12V - Quick

Motoriduttore 1400W 12V

Motoriduttore 700W 24V - Quick

Motoriduttore 1000W 24V - Quick

Motoriduttore 1400W 24V

CODICE

ZSR0712Q0000

ZSR1012Q0000

ZSR141200000

ZSR0724Q0000

ZSR1024Q0000

ZSR142400000

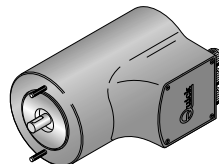
**MOTORE - ARIES FLAIR RIDER**

Motore 700W 12V

Motore 1000W 12V

Motore 1400W 12V

Motore 700W 24V

Motore 1000W 24V

Motore 1400W 24V

CODICE

ZSM071200000

ZSM101200000

ZSM141200000

ZSM072400000

ZSM102400000

ZSM142400000



HOW TO IDENTIFY THE WINDLASS THROUGH THE CODE:

1° EXAMPLE: FLAIR724D

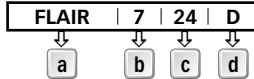

2° EXAMPLE: RIDER1012

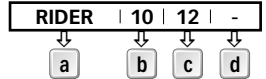

a

Name of the line:

[ARIES] = oval base in aluminium
 [FLAIR B] = oval base in black fiber-glass
 [FLAIR W] = oval base in white fiber-glass
 [RIDER] = round base in aluminium

b

Motor output:

[7] = 700 W
 [10] = 1000 W
 [14] = 1400 W

c

Motor supply voltage:

[12] = 12 V
 [24] = 24 V

d

Drum:

[D] = with drum
 [-] = without drum

MODEL		ARIES - / D						FLAIR - / D						RIDER - / D					
MOTOR POWER	W	700		1000		1400		700		1000		1400		700		1000		1400	
Motor supply voltage	V	12	24	12	24	12	24	12	24	12	24	12	24	12	24	12	24	12	24
Maximum pull	kg	850		1000		1100		850		1000		1100		850		1000		1100	
	lb	1874		2205		2425		1874		2205		2425		1874		2205		2425	
Maximum working load	kg	250	300	370	450	450	500	250	300	370	450	450	500	250	300	370	450	450	500
	lb	551	661	815	992	992	1100	551	661	815	992	992	1100	551	661	815	992	992	1100
Working load	kg	80	100	120	150	150	170	80	100	120	150	150	170	80	100	120	150	150	170
	lb	176	220	264.5	330.7	330.7	374.8	176	220	264.5	330.7	330.7	374.8	176	220	264.5	330.7	330.7	374.8
Current absorption working load ⁽¹⁾	A	90	55	140	80	155	85	90	55	140	80	155	85	90	55	140	80	155	85
Maximum chain speed ⁽²⁾	m/min	27.4	26.4	39.6	40.9	33.0	29.7	27.4	26.4	39.6	40.9	33.0	29.7	27.4	26.4	39.6	40.9	33.0	29.7
	ft/min	90.0	86.6	130.0	134.2	108.0	97.4	90.0	86.6	130.0	134.2	108.0	97.4	90.0	86.6	130.0	134.2	108.0	97.4
Maximum chain speed @ working load ⁽²⁾	m/min	14.4	14.8	20.4	21.4	17.5	20.5	14.4	14.8	20.4	21.4	17.5	20.5	14.4	14.8	20.4	21.4	17.5	20.5
	ft/min	47.2	48.6	67.0	70.2	57.4	67.2	47.2	48.6	67.0	70.2	57.4	67.2	47.2	48.6	67.0	70.2	57.4	67.2
Motor cable size ⁽³⁾	mm ²	25	10	35	16	50	25	10	35	16	50	25	10	35	16	50	25	10	35
	AWG	3	7	2	5	0	3	3	7	2	5	0	3	3	7	2	5	0	3
Protection circuit breaker ⁽⁴⁾	A	50	40	80	50	100	50	50	40	80	50	100	50	50	40	80	50	100	50
Weight modell without drum	kg	17.4		18.5		20.8		16.5		17.6		19.9		16.0		17.1		19.4	
	lb	38.4		40.8		45.9		36.4		38.8		43.9		35.3		37.7		42.8	
Weight modell with drum	kg	19.3		20.4		22.7		22.7		18.4		19.5		18.0		19.1		21.4	
	lb	42.6		45.0		50.0		46.0		43.0		48.1		39.7		42.1		47.2	

- (1) After an initial period of use.
- (2) Measurements taken with a gypsy for a 8 mm chain.
- (3) Minimum allowable value for a total length L<20m (see pag. 44). Determine the cable size according to the length of the wiring.
- (4) With circuit breaker designed for direct currents (DC) and delayed-action (thermal-magnetic or hydraulic-magnetic).

GYPSYES (*)	6mm	8mm - 5/16"	10mm - 3/8"
Chain size	DIN 766 / ISO (**)	DIN 766 / ISO (**) / G4 / BBB	DIN 766 / ISO (**) / G4

- (*) For the gypsy codes, please consult the exploded drawing on page 16.
- (**) ISO EN 818-3.

DIMENSIONS mm (inch)	ARIES/FLAIR - / D			RIDER - / D		ARIES/FLAIR - / D		RIDER - / D	
	700W	1000W		700W	1000W	1400W			
A	98 (3" 27/32)			100 (3" 15/16)		98 (3" 27/32)	100 (3" 15/16)		
B	164 (6" 7/16)			166 (6" 17/32)		164 (6" 7/16)	166 (6" 17/32)		
C	141 (5" 9/16)			179 (7")		179 (7")			
D	250 (9" 27/32)			159 (6" 1/4)		250 (9" 27/32)	159 (6" 1/4)		
E	141 (5" 9/16)					141 (5" 9/16)			
F	87 (3" 7/16)			Ø 155 (6" 3/32)		87 (3" 7/16)	Ø 155 (6" 3/32)		
G	78 (3" 23/32)					78 (3" 23/32)			
H	330 (13")	340 (13" 3/8)		330 (13")	340 (13" 3/8)		385 (15" 1/8)		
I	25 ± 50 mm (31/32" ± 1" 31/32") ⁽⁵⁾						30 ± 50 mm (1" 3/32 ± 1" 31/32") ⁽⁵⁾		

- (5) On request, shafts and studs can be supplied for greater deck thicknesses.

700 / 1000 / 1400 W ARIES - FLAIR - / D

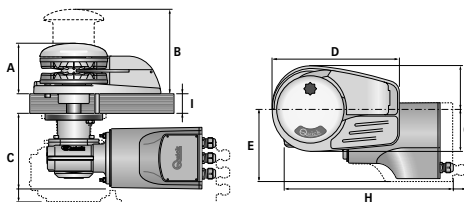

700 / 1000 / 1400 W RIDER - / D

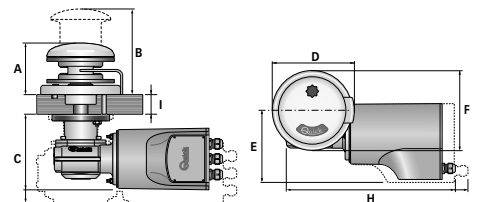

Quick® reserves the right to introduce changes to the equipment and the contents of this manual without prior notice. In case of discordance or errors in translation between the translated version and the original text in the Italian language, reference will be made to the Italian or English text.



BEFORE USING THE WINDLASS READ THESE INSTRUCTIONS CAREFULLY. IF IN DOUBT, CONTACT YOUR NEAREST "QUICK" DEALER.

- WARNING:** the Quick® windlasses are designed to weigh the anchor. Do not use the equipment for other purposes. Quick® shall not be held responsible for damage to equipment and/or personal injury, caused by a faulty use of the equipment.
- The windlass is not designed for the loads that might occur in extreme weather conditions (storms).
- Always deactivate the windlass when not in use. Check that there are no swimmers nearby before dropping anchor.
- The splice between the rope and the chain must be tightly woven for the rope to slide easily into the gypsy shape. For any problem or request, feel free to contact Quick® Technical Service. For improved safety we recommend installing at least two anchor windlass controls in case one is accidentally damaged.
- We recommend the use of the Quick® hydraulic-magnetic switch as the motor safety switch.
- Secure the chain with a further device before starting the navigation.
- The contactor unit or reversing contactor unit must be installed in a point protected from accidental water contact.

THE PACKAGE CONTAINS: windlass (on deck unit + motorgearbox) - contactor unit - base gasket - drill template - handle - bolts and screws (for assembly) - user's manual - conditions of warranty.

TOOLS REQUIRED FOR INSTALLATION: drill and drill bits: Ø 9 mm (23/64") and Ø 11 mm (7/16") - Ø 53 mm (2"1/16) and Ø 70 mm (2"3/4) hollow mill; hexagonal wrench: 13 mm.

"QUICK" ACCESSORIES RECOMMENDED: anchoring RL control board (mod. 800) - Waterproof hand helds R/C (mod. HRC1002) - Foot switch (mod. 900) - Hydraulic-magnetic circuit breaker - Anchor chain counter (mod. CHC1102M and CHC1202M) - Radio control (mod. 1302,1352; 02, 302).

INSTALLATION REQUIREMENTS: the windlass must be positioned with the gypsy aligned with the bow roller. Ensure that the upper and lower surfaces of the deck are as parallel as possible. If this is not the case, compensate the difference appropriately (a lack of parallelism could result in a loss of motor power). The deck thickness must be included among the figures listed in the table. In cases of other thicknesses it is necessary to consult a Quick® retailer. There must be no obstacles under deck to the passage of cables, rope and chain; lack of depth of the peak could cause jamming.

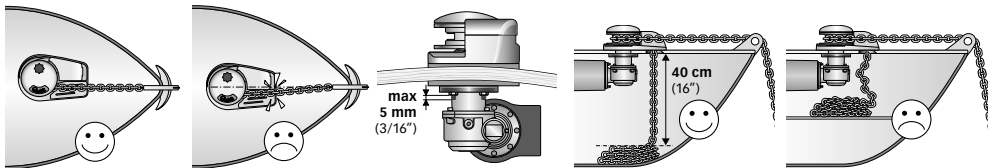

FITTING PROCEDURE: when the ideal position has been established, drill four holes using the drilling template provided. Remove excess material from the chain passage, refine and flatten with a specialized product (marine paint, gel coat or 2 pack epoxy) to assure free passage for both rope and chain. Position the upper section, inserting the gasket between the deck and the base and connect the lower section to the assembly, inserting the shaft into the reduction unit. Fix the windlass by screwing the nuts onto the fixing studs. Connect the supply cables from the windlass to the contactor unit.

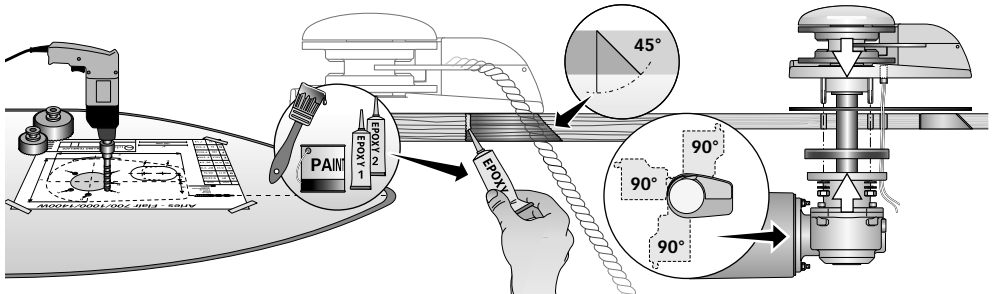

- WARNING:** before wiring up, be sure the electrical cables are not live.



BASIC SYSTEM

SEE PAGE 44
SHOWING THE MAIN
CONNECTION DIAGRAM

MULTI-PURPOSE
WATERTIGHT HAND HELD
REMOTE CONTROL
MOD. HRC 1002

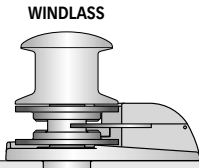

WINDLASS



QUICK® ACCESSORIES FOR WINDLASS OPERATION



WATERTIGHT HAND HELD
CHAIN COUNTER

WINDLASSES
CONTROL
BOARD

WATERTIGHT
PANEL
CHAIN COUNTER



REMOTE RADIO CONTROLS

RECEIVERS

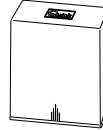

TRANSMITTERS

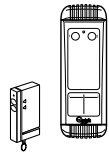

RADIO POCKET - HAND SET

FOOT SWITCHES MOD. 900U AND 900D

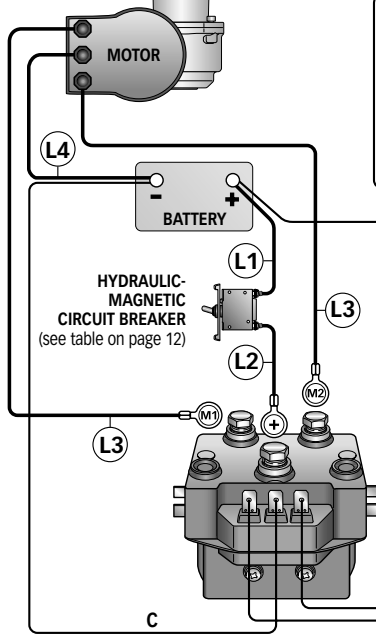





CONTACTOR UNIT
MOD. T6315-12 (12V)
MOD. T6315-24 (24V)

FUSE
4A (12V)
2A (24V)

$$L = (L1) + (L2) + (L3) + (L4)$$



WARNING

-  **WARNING:** stay clear of the chains, ropes and gypsy. Make sure the electric motor is off when windlass is used manually (even when using the handle to disengage the clutch). In fact people with windlass remote controls (hand-held remote control or radio-controlled systems) might accidentally operate it.
-  **WARNING:** secure the chain with a device before starting the navigation.
-  **WARNING:** do not operate the windlass by using the electrical power when the handle is inserted in the drum or into the gypsy cover.
-  **WARNING:** Quick® recommend using a circuit breaker designed for direct current (DC) with delayed-action (thermal-magnetic or hydraulic-magnetic) to protect the motor supply line from overheating or short circuits. The circuit breaker can be used to cut off power to the windlass control circuit and so avoid accidental activation.

CLUTCH USE

The clutch (5) provides a link between the gypsy (6) and the main shaft (13 or 14). The clutch can be released (disengagement) by using the handle (1) which, when inserted in the bush of the drum or in the gypsy cover (3 or 2), must be turned counter-clockwise. The clutch will be re-engaged by turning it clockwise (engagement).

WEIGHING THE ANCHOR

Turn on the engine. Make sure the clutch (5) is engaged and remove the handle (1).

Press the UP button on the control provided.

If the windlass stops and the hydraulic magnetic switch (or thermal cutout) has not tripped, wait a few seconds and try again (avoid keeping the button pressed).

If the hydraulic magnetic switch, has tripped, reset it and wait a few minutes before weighing anchor once again.

If, after a number of attempts, the windlass is still blocked, we suggest to move the boat to release the anchor. Check the upward movement of the chain for the last few meters in order to avoid damages to the bow.

CASTING THE ANCHOR

The anchor can be cast by using the electrical control or manually. To operate manually, the clutch (5) must be disengaged allowing the gypsy (6) to revolve and letting the rope or chain fall into the water.

To slow down the chain, the handle (1) must be turned clockwise.

To cast the anchor by using the electrical power, press the DOWN button on the control provided. In this manner, anchor casting is under control and the chain and rope unwind evenly.

In order to avoid any stress on the windlass -once the boat is anchored- fasten the chain or secure it in place with a rope.



POS.	DESCRIPTION	CODE
1A	Handle 700-1000W	MSHD00000000
1B	Handle 1400W	ZSLMSH000000
2	Gypsy cover	MSGB10000R01
3	Bush	MSD10000R01
4	Drum	ZSGMSE100000
5	Clutch cone	MSF100000000
6A	Gypsy 6 mm	ZSB100600000
6B	Gypsy 8 mm-5/16"	ZSB1008516R4
6C	Gypsy 10 mm-3/8"	ZSB1010380AR
7	Magnet	KPMC08060000
8	Spring washer	MBR254025X00
9	Oil seal	PGPRL2547700
10	Internal circlip	MBAN4717Y000
11	External circlip	MBAE2520Y000

POS.	DESCRIPTION	CODE
12	Bearing	MBJ60052RS10
13	Short shaft	MSAS10274R30
14	Long shaft	MSAS10308R30
15	Key	MBH080780F00
16A	Chain guide cover A	SGMSGG100000
16B	Chain guide cover white F	PDGC10DW0000
16C	Chain guide cover black F	PDGC10DB0000

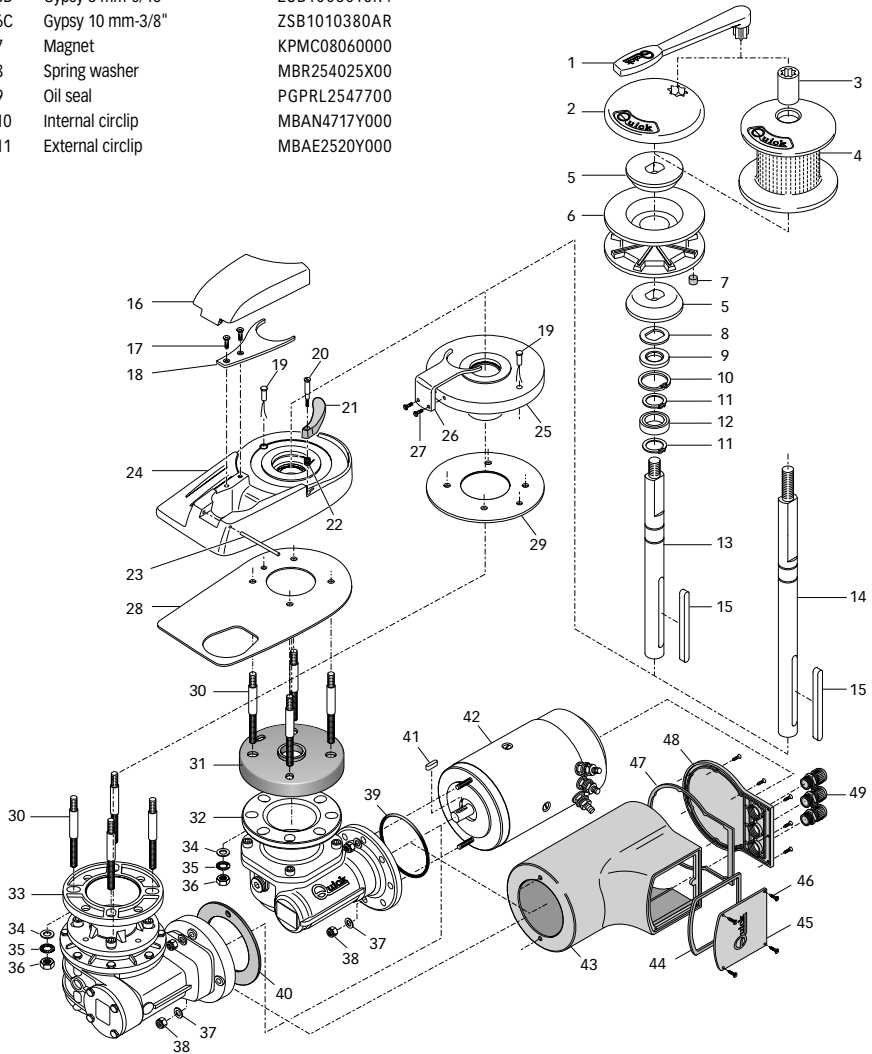



POS.	DESCRIPTION	CODE
17A	Screw Aries base	MBV0516MXSC0
17B	Screw Flair base	MBV0530MXSC0
18A	Rope/chain stripper Aries base	MSN10VXP0000
18B	Rope/chain stripper Flair base	MSN10VXD0000
19	Sensor	SAKREED00000
20	Screw for pressure lever	MSMVT1000000
21A	Black pressure lever	PDLVTD1000000
21B	White pressure lever	PDLVTD10W0000
22	Spring for gypsy pressure lever	MMTND1000000
23	Cover pin	MSR10X0000000
24A	base ovale Aries	SGMSC10V0000
24B	Oval base Aries	SMPD10VW00000
24C	Oval base white Flair	SMPD10VB0000
25	Oval base black Flair	SGMSC10C0000
26	Rope/chain stripper R base	MSN10CX00000
27	Screw Rider base	MBV0620MXSC0
28	Gasket/A-F - shaped jig	PGBSV1000000
29	Gasket/R - shaped jig	PGBSC1000000
30A	Studs Aries base	MBP080807X00
30B	Studs Flair base	MBP080808X00
31	Gearbox flange gasket Top TG50	PGFLRDTG50000
32	Gearbox 700/1000W Quick TG50	SLMR10TG5000
33	Gearbox 1400W	MR14000000000
34	Washer	MBR08X000000
35	Spring washer	MBR08XDE0000
36	Nut	MBD08MXEN000
37	Washer	MBR061815X00
38	Self-locking nuts	MBD06MXET000
39	O-ring	-
40	Gasket motorgearbox	PGNP100000000
41	Key	MBH050515F00
42A	Electric motor 700W 12V	EMF071200000
42B	Electric motor 700W 24V	EMF072400000
42C	Electric motor 1000W 12V	EMF101200000
42D	Electric motor 1000W 24V	EMF102400000
42E	Electric motor 1400W 12V	EMF141200000
42F	Electric motor 1400W 24V	EMF142400000
43A	Motor casing watertight 700W	PCCCPM070000
43B	Motor casing watertight 10/1400W	PCCCPM100000
44	Grommet 1000/1400W	PCGPMMR00000
45	Terminal board cover	PCCPPMMR0000
46	Screw	MBV02213AXSC
47	Bottom gasket	PGGPMFN00000
48	Bottom protec cover	PCCPPMFN0000
49	Cable outlet	PPM20B000000



WARNING: make sure the electrical power to the motor is switched off when working manually on the windlass. Carefully remove the chain or rope from the gypsy or the rope from the drum.

Quick® windlasses are manufactured with materials resistant to marine environments. In any case, any salt deposits on the outside must be removed periodically to avoid corrosion and damage to the equipment. The parts where salt may have built up should be washed thoroughly with fresh water.

Once a year, the drum and the gypsy are to be taken apart as follows:

DRUM VERSION

Use the handle (1) to loosen the bush (3); pull off the drum (4) and the top clutch cone (5); loosen the fixing screws (17 or 27) of the rope/chain stripper (18 or 26) and remove it. Pull off the gypsy (6).

NO-DRUM VERSION

Use the handle (1) to remove the gypsy cover (2); remove the top clutch cone (5); loosen the fixing screws (17 or 27) of the rope/chain stripper (18 or 26) and remove it and pull off the gypsy (6).

Clean all the parts removed to avoid corrosion, and grease the shaft thread (13 and 14) and the gypsy (6) where the clutch cones (5) rest (use grease suitable for marine environment) .

Periodically grease the hinge pin (23) of the chain guide cover (16) (only windlasses with aluminium bases).

Remove any oxide deposits from the terminals of the electric motor and the contactor unit; grease them.

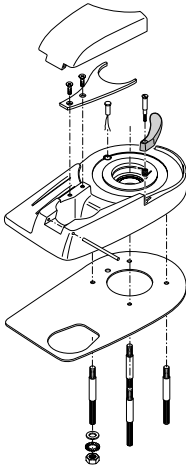
**COMPLETE BASE - ARIES/FLAIR**

	CODE
Windlass base 700/1000/1400W "ARIES"	ZSBSA010C000
Windlass base 700/1000/1400W "FLAIR BLACK"	ZSBSFB10C000
Windlass base 700/1000/1400W "FLAIR WHITE"	ZSBSFW10C000

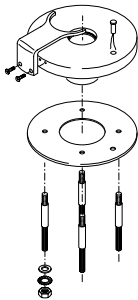
**COMPLETE BASE - RIDER**

	CODE
Windlass base 700/1000/1400W "RIDER"	ZSBSR010C000

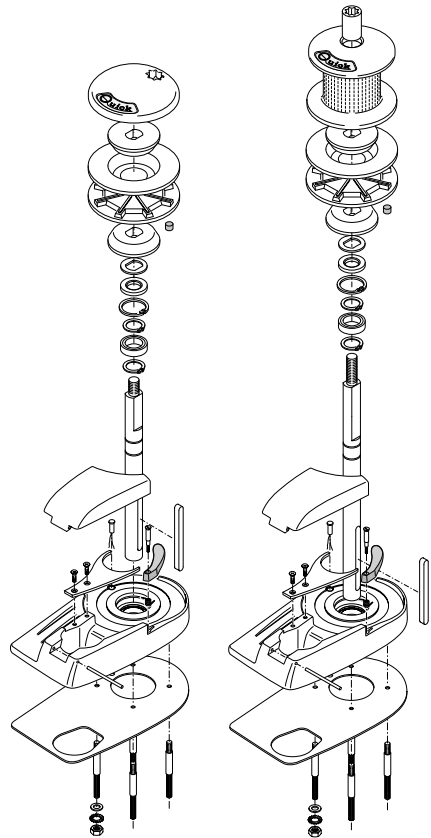
**TOP WITHOUT DRUM - ARIES/FLAIR**

	CODE
Top series A 7/10/1400W 6 mm	ZSTA01000600
Top series A 7/10/1400W 8 mm-5/16"	ZSTA01000851
Top series A 7/10/1400W 10 mm-3/8"	ZSTA01001038
Top series F Black 7/10/1400W 6 mm	ZSTFB1000600
Top series F Black 7/10/1400W 8 mm-5/16"	ZSTFB1000851
Top series F White 7/10/1400W 6 mm	ZSTFW1000600
Top series F White 7/10/1400W 8 mm-5/16"	ZSTFW1000851

TOP WITH DRUM - ARIES/FLAIR

Top series A 7/10/1400W 6mm D	ZSTA010D0600
Top series A 7/10/1400W 8 mm-5/16" D	ZSTA010D0851
Top series A 7/10/1400W 10 mm-3/8" D	ZSTA010D1038
Top series F Black 7/10/1400W 6 mm D	ZSTFB10D0600
Top series F Black 7/10/1400W 8 mm-5/16" D	ZSTFB10D0851
Top series F White 7/10/1400W 6 mm D	ZSTFW10D0600
Top series F White 7/10/1400W 8 mm-5/16" D	ZSTFW10D0851

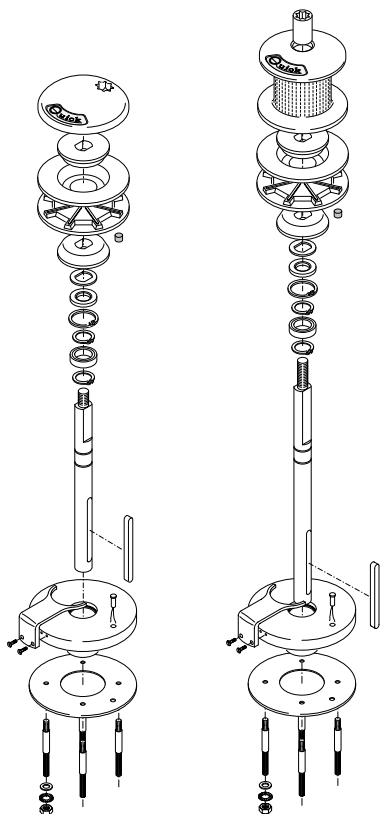
**TOP WITHOUT DRUM - RIDER**

Top series R 7/10/1400W 6 mm

Top series R 7/10/1400W 8 mm-5/16"

Top series R 7/10/1400W 10 mm-3/8"

TOP WITH DRUM - RIDER

Top series R 7/10/1400W 6 mm D

Top series R 7/10/1400W 8 mm-5/16" D

Top series R 7/10/1400W 10 mm-3/8" D

CODE

ZSTR01000600

ZSTR01000851

ZSTR01001038

ZSTR010D0600

ZSTR010D0851

ZSTR010D1038

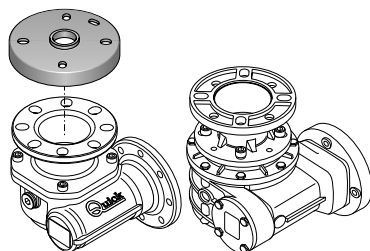
**GEARBOX - ARIES FLAIR RIDER**

Gearbox 700/1000W - Quick TG50 series

Gearbox 1400W

CODE

SLMR10TG5000

MR1400000000

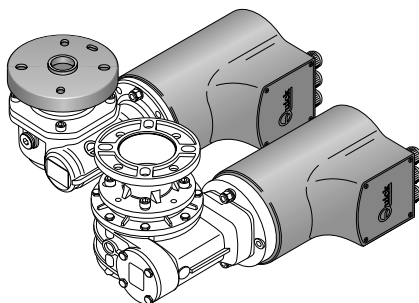
**MOTORGEARBOX - ARIES FLAIR RIDER**

Motorgearbox 700W 12V - Quick

Motorgearbox 1000W 12V - Quick

Motorgearbox 1400W 12V

Motorgearbox 700W 24V - Quick

Motorgearbox 1000W 24V - Quick

Motorgearbox 1400W 24V

CODE

ZSR0712Q0000

ZSR1012Q0000

ZSR141200000

ZSR0724Q0000

ZSR1024Q0000

ZSR142400000

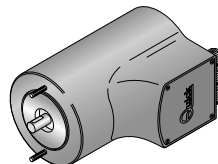
**ELECTRIC MOTOR - ARIES FLAIR RIDER**

Electric motor 700W 12V

Electric motor 1000W 12V

Electric motor 1400W 12V

Electric motor 700W 24V

Electric motor 1000W 24V

Electric motor 1400W 24V

CODE

ZSM071200000

ZSM101200000

ZSM141200000

ZSM072400000

ZSM102400000

ZSM142400000



COMMENT LIRE LE CODE DE GUINDEAUX:

1° EXEMPLE: FLAIR724D

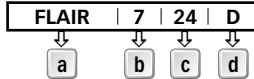

2° EXEMPLE: RIDER1012

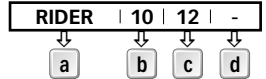

a

Nom de la série:

- [ARIES] = base oval en aluminium
- [FLAIR B] = base oval en fibre noire
- [FLAIR W] = base oval en fibre blanche
- [RIDER] = base circulaire en aluminium

b

Puissance moteur:

- [7] = 700 W
- [10] = 1000 W
- [14] = 1400 W

c

Tension d'alimentation moteur:

- [12] = 12 V
- [24] = 24 V

d

Poupée:

- [D] = avec poupée
- [-] = sans poupée

MODÈLE	ARIES - / D						FLAIR - / D						RIDER - / D						
PUISANCE DU MOTEUR	W	700		1000		1400		700		1000		1400		700		1000		1400	
Tension d'alimentation moteur	V	12	24	12	24	12	24	12	24	12	24	12	24	12	24	12	24	12	24
Traction maximum	kg	850	1000	1100	1100	850	1000	1100	850	1000	1100	850	1000	1100	850	1000	1100		
	lb	1874	2205	2425	2425	1874	2205	2425	1874	2205	2425	1874	2205	2425	1874	2205	2425		
Charge de travail maximale	kg	250	300	370	450	450	500	250	300	370	450	450	500	250	300	370	450	450	500
	lb	551	661	815	992	992	1100	551	661	815	992	992	1100	551	661	815	992	992	1100
Charge de travail	kg	80	100	120	150	150	170	80	100	120	150	150	170	80	100	120	150	150	170
	lb	176	220	264,5	330,7	330,7	374,8	176	220	264,5	330,7	330,7	374,8	176	220	264,5	330,7	330,7	374,8
Absorption de courant à la charge de travail (1)	A	90	55	140	80	155	85	90	55	140	80	155	85	90	55	140	80	155	85
Vitesse maximale de recuperation (2)	m/min	27,4	26,4	39,6	40,9	33,0	29,7	27,4	26,4	39,6	40,9	33,0	29,7	27,4	26,4	39,6	40,9	33,0	29,7
	ft/min	90,0	86,6	130,0	134,2	108,0	97,4	90,0	86,6	130,0	134,2	108,0	97,4	90,0	86,6	130,0	134,2	108,0	97,4
Vitesse de récupération à la charge de travail (2)	m/min	14,4	14,8	20,4	21,4	17,5	20,5	14,4	14,8	20,4	21,4	17,5	20,5	14,4	14,8	20,4	21,4	17,5	20,5
	ft/min	47,2	48,6	67,0	70,2	57,4	67,2	47,2	48,6	67,0	70,2	57,4	67,2	47,2	48,6	67,0	70,2	57,4	67,2
Section minimale du câble du moteur (3)	mm ²	25	10	35	16	50	25	10	35	16	50	25	10	35	16	50	25	10	35
	AWG	3	7	2	5	0	3	3	7	2	5	0	3	3	7	2	5	0	3
Disjoncteur (4)	A	50	40	80	50	100	50	50	40	80	50	100	50	50	40	80	50	100	50
	kg	17,4	18,5	20,8	22,7	16,5	17,6	17,4	18,5	20,8	22,7	16,5	17,6	17,4	18,5	20,8	22,7	16,5	17,6
Poids modèle sans poupée	lb	38,4	40,8	45,9	50,0	36,4	38,8	38,4	40,8	45,9	50,0	36,4	38,8	38,4	40,8	45,9	50,0	36,4	38,8
	kg	19,3	20,4	22,7	22,7	18,4	19,5	18,4	19,5	22,7	22,7	18,4	19,5	18,4	19,5	22,7	22,7	18,4	19,5
Poids modèle avec poupée	kg	42,6	45,0	50,0	50,0	40,6	43,0	42,6	45,0	50,0	50,0	40,6	43,0	42,6	45,0	50,0	50,0	40,6	43,0

- (1) A l'arrêt, après utilisation.
- (2) Mesures effectuées avec barbotin pour chaîne de 8 mm.
- (3) Valeur minimale conseillée pour une longueur totale L < 20m (voir pag. 44). Déterminer la grandeur du câble requise selon la longueur de la connexion.
- (4) Avec des disjoncteurs conçus pour courants continus (DC) et retardés (magnétique-thermique ou magnétique-hydraulique).

BARBOTIN (*)	6mm	8mm - 5/16"	10mm - 3/8"
Chaîne soutenue	DIN 766 / ISO (**)	DIN 766 / ISO (**)/ G4 / BBB	DIN 766 / ISO (**)/ G4

- (*) Pour les codes des barbotins, voir le schéma éclaté à la page 24. (**) ISO EN 818-3.

DIMENSIONS mm (inch)	ARIES/FLAIR - / D		RIDER - / D		ARIES/FLAIR - / D		RIDER - / D	
	700W	1000W	700W	1000W	1400W			
A	98 (3" 27/32)		100 (3" 15/16)		98 (3" 27/32)	100 (3" 15/16)		
B	164 (6" 7/16)		166 (6" 17/32)		164 (6" 7/16)	166 (6" 17/32)		
C	141 (5" 9/16)		179 (7")		179 (7")			
D	250 (9" 27/32)		159 (6" 1/4)		250 (9" 27/32)	159 (6" 1/4)		
E	141 (5" 9/16)		141 (5" 9/16)		141 (5" 9/16)			
F	87 (3" 7/16)		Ø 155 (6" 3/32)		87 (3" 7/16)	Ø 155 (6" 3/32)		
G	78 (3" 23/32)		78 (3" 23/32)		78 (3" 23/32)			
H	330 (13")	340 (13" 3/8)	330 (13")	340 (13" 3/8)	385 (15" 1/8)			
I	25 ± 50 mm (31/32" ± 1" 31/32") (3)				30 ± 50 mm (1" 3/32 ± 1" 31/32") (3)			

- (5) Il peut être fourni, sur demande, des arbres et des prisonniers pour des ponts d'épaisseur plus élevée.

700 / 1000 / 1400 W ARIES - FLAIR - / D

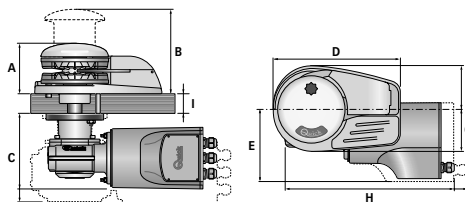

700 / 1000 / 1400 W RIDER - / D

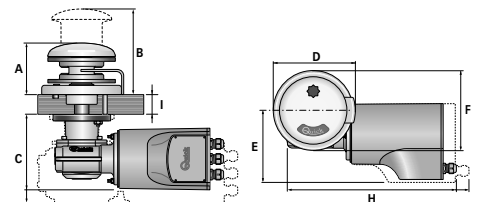

La société Quick® se réserve le droit d'apporter les modifications nécessaires aux caractéristiques techniques de l'appareil et au contenu de ce livret sans avis préalable. En cas de discordances ou d'erreurs éventuelles entre la traduction et le texte original en italien, se référer au texte italien ou anglais.



AVANT D'UTILISER LE GUINDEAU, LIRE ATTENTIVEMENT CE LIVRET D'INSTRUCTIONS. EN CAS DE DOUTES, S'ADRESSER AU REVENDEUR QUICK®.

- ⚠ **ATTENTION:** les guindeaux Quick® ont été conçus et construits pour lever l'ancre. ⚠ Ne pas utiliser ces appareils pour effectuer d'autres types d'opérations. ⚠ La Société Quick® n'assume aucune responsabilité pour les dommages directs ou indirects causés par un mauvais usage de l'appareil. ⚠ Le guindeau n'a pas été prévu pour soutenir les charges provoquées lors de conditions atmosphériques particulières (tempête). ⚠ Toujours désactiver le guindeau quand il n'est pas utilisé. ⚠ Avant de jeter l'ancre, vérifier qu'il n'y a pas de baigneur à proximité.
- ⚠ L'épaisseur entre le cordage et la chaîne doit avoir des dimensions réduites pour pouvoir glisser aisément dans le gabarit du barbotin. Pour tout problème ou toute demande, contacter l'assistance Quick®.
- ⚠ Pour une plus grande sécurité, nous suggérons d'installer au moins deux commandes pour actionner le guindeau au cas où une de celle-ci s'abîmerait. ⚠ Fixer la chaîne avec un dispositif d'arrêt avant de partir pour la navigation.
- ⚠ Nous conseillons l'utilisation de l'interrupteur magnétique-hydraulique Quick® comme sécurité pour le moteur.
- ⚠ La boîtier relais ou relais inverseurs doit être installée dans un endroit protégé des éventuelles entrées d'eau.

L'EMBALLAGE COMPREND: guindeau (partie supérieure + motoréducteur) - boîtier relais - joint de la base - gabarit de perçage - levier - différentes vis (pour l'assemblage) - livret d'instructions - conditions de garantie.

OUTILS NECESSAIRES POUR L'INSTALLATION: perceuse avec mèches: Ø 9 mm (23/64") et Ø 11 mm (7/16"); à gorges Ø 53 mm (2"1/16) et Ø 70 mm (2"3/4); clé hexagonale: 13 mm.

ACCESSOIRES QUICK® RECOMMANDES: interrupteur sur panneau (mod. 800) - Télécommande étanche (mod. HRC1002) - Bouton à pied (mod. 900) - Disjoncteur magnétique-hydraulique - Compteur de chaîne pour l'ancrage (mod. CHC1102M et CHC1202M) - Système de commande par radio (mod. 1302, 1352; 02, 302).

CONDITIONS REQUISES POUR L'INSTALLATION: le guindeau doit être positionné en alignant le barbotin avec le creux de proue. Contrôler que les surfaces supérieures et inférieures du pont soient les plus parallèles possibles, si ce n'est pas le cas, compenser la différence de manière opportune (le manque de parallélisme pourrait provoquer des pertes de puissance du moteur). L'épaisseur du pont devra être comprise parmi les valeurs indiquées dans le tableau. En cas d'épaisseurs différentes, s'adresser au revendeur Quick®. Il ne doit pas y avoir d'obstacles sous le pont pour le passage des câbles, des cordages et des chaînes, le peu de profondeur du coqueron pourrait provoquer des coincements.

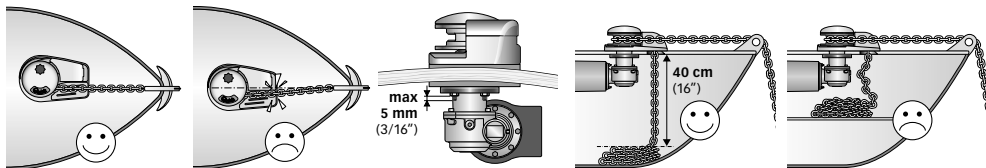

METHODE DE MONTAGE: une fois que la position idéale est établie, faire les trous en utilisant le gabarit de perçage fourni avec l'appareil. Enlevez le matériel en excès de l'écubier de puits à chaînes, fignolez et lissez l'écubier avec un produit spécifique (peinture marine, enduit gélifié or résine epoxy) en assurant le passage libre du bout et de la chaîne. Positionner la partie supérieure en insérant le joint entre le pont et la base et relier la partie inférieure à celle-ci en enfilant l'arbre dans le réducteur. Fixer le guindeau avec les écrous fournis sur les goujons de fixation. Brancher les câbles d'alimentation provenant du guindeau au relais.

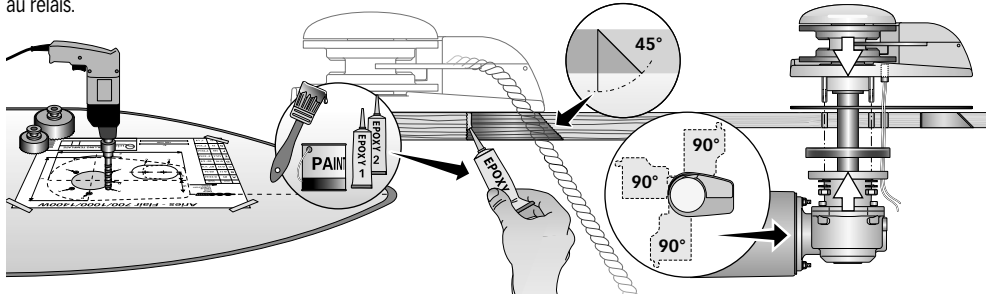

- ⚠ **ATTENTION:** avant d'effectuer la connexion, contrôler que les câbles ne soient pas alimentés électriquement.



SYSTEME DE BASE

SCHÉMA DE CONNEXION
GENERAL À LA PAGE 44

TELECOMMANDE À
FONCTION MULTIPLE
MOD. HRC 1002

GUINDEAU

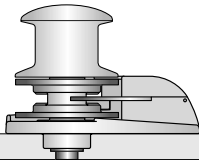

ACCESSOIRES QUICK®
POUR ACTIONNER LE GUINDEAU



TELECOMMANDE AVEC
COMPTEUR DE CHAÎNE

COMMANDE
DU TABLEAU



RADIOCOMMANDES

RÉCEPTEUR

EMETTEUR

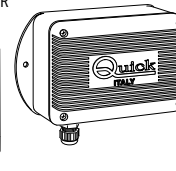
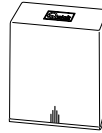

MIGNON
TABLEAU DE
COMMANDE



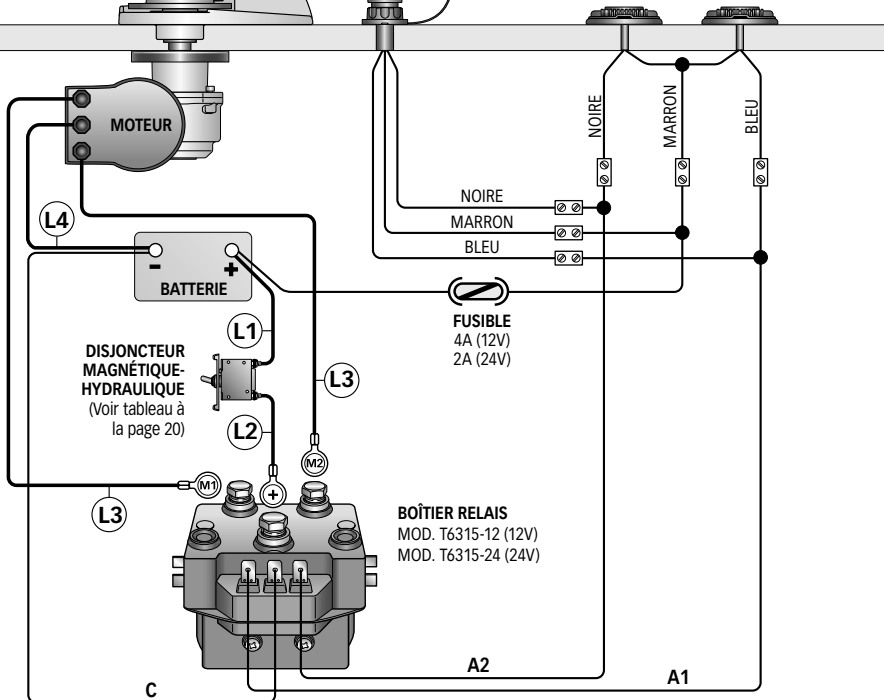

BOUTONS À PIED MOD. 900U ET 900D



$$L = (L1) + (L2) + (L3) + (L4)$$



AVERTISSEMENTS IMPORTANTS

-  **ATTENTION:** ne pas s'approcher de la zone où glissent la chaîne, le cordage et le barbotin. Contrôler que le moteur ne soit pas alimenté électriquement quand on travaille manuellement sur le guindeau (même quand on utilise le levier pour desserrer l'embrayage); en effet, les personnes munies de commande à distance pour le guindeau (tableau des boutons-poussoirs télécommandé ou radiocommandé) pourraient l'activer involontairement.
-  **ATTENTION:** fixer la chaîne avec un dispositif d'arrêt avant de partir pour la navigation.
-  **ATTENTION:** ne pas activer électriquement le guindeau avec le levier introduit dans la poupée ou dans le couvercle du barbotin.
-  **ATTENTION:** Quick® conseille d'utiliser un disjoncteur spécifique pour courant continu (DC) et retardé (magnéto-thermique ou magnéto-hydraulique) pour protéger la ligne du moteur des surchauffes ou des courts-circuits. Le disjoncteur peut être utilisé pour isoler le circuit de commande du guindeau en évitant ainsi des actionnements accidentels.

UTILISATION DE L'EMBRAYAGE

Le barbotin (6) est solidaire de l'arbre principal (13 ou 14) de l'embrayage (5). L'embrayage s'ouvre (déblocage) à l'aide du levier (1) qui, une fois introduit dans la douille de la poupée ou dans le couvercle du barbotin (3 ou 2), devra tourner dans le sens contraire aux aiguilles de la montre. Si l'on tourne dans le sens des aiguilles d'une montre, l'embrayage se fermera (blocage).

POUR LEVER L'ANCRE

Allumer le moteur de l'embarcation. S'assurer si l'embrayage est bien serré et tirer le levier (1).

Presser le bouton UP de la commande à votre disposition.

Si le guindeau s'arrête sans que le disjoncteur magnéto-hydraulique (ou magnéto-thermique) se soit déclenché, attendre quelques secondes et ré-essayer (éviter de presser le bouton en continu). Si le disjoncteur magnéto-thermique s'est déclenché, réactiver le disjoncteur et attendre quelques minutes avant de reprendre l'opération. Si, après plusieurs tentatives, le guindeau continue à se bloquer, nous recommandons d'effectuer des manoeuvres avec l'embarcation pour désensabler l'ancre.

Contrôler la montée des derniers mètres de chaîne pour éviter des dommages à l'avant de l'embarcation.

POUR JETER L'ANCRE

Il est possible de jeter l'ancre par l'intermédiaire des commandes électriques ou bien manuellement.

Pour effectuer l'opération manuellement, ouvrir l'embrayage (5) en laissant que le barbotin (6) puisse tourner sur son propre axe et traîner la chaîne ou le cordage dans l'eau.

Pour freiner la descente de l'ancre, tourner le levier (1) dans le sens des aiguilles d'une montre.

Pour jeter l'ancre électriquement, presser le bouton DOWN de la commande à votre disposition. De cette manière-là, la descente peut être bien contrôlée et le déroulement de la chaîne ou du cordage est régulier. Pour éviter tout effort sur le guindeau, une fois que l'on est ancrés, bloquer la chaîne avec un dispositif d'arrêt ou bien la fixer à un point solide avec un bout.



POS.	DENOMINATION	CODE
1A	Levier 700-1000W	MSHD0000000
1B	Levier 1400W	ZSLMSH000000
2	Couvercle du barbotin	MSGB10000R01
3	Douille	MSD10000R01
4	Poupée	ZSGMSE100000
5	Cône de l'embrayage	MSF100000000
6A	Barbotin 6 mm	ZSB100600000
6B	Barbotin 8 mm-5/16"	ZSB1008516R4
6C	Barbotin 10 mm-3/8"	ZSB1010380AR
7	Aimant	KPMC08060000
8	Rondelle	MBR254025X00
9	Joint étanche à l'huile	PGPRL2547700
10	Circlip intérieur	MBAN4717Y000
11	Circlip extérieur	MBAE2520Y000

POS.	DENOMINATION	CODE
12	Roulement	MBJ60052RS10
13	Arbre court	MSAS10274R30
14	Arbre long	MSAS10308R30
15	Clavette	MBH080780F00
16A	Couvercle guide du chaîne A	SGMSGG100000
16B	Couvercle guide du chaîne F de verre blanche	PDGC10DW0000
16C	Chain guide cover black F	PDGC10DB0000

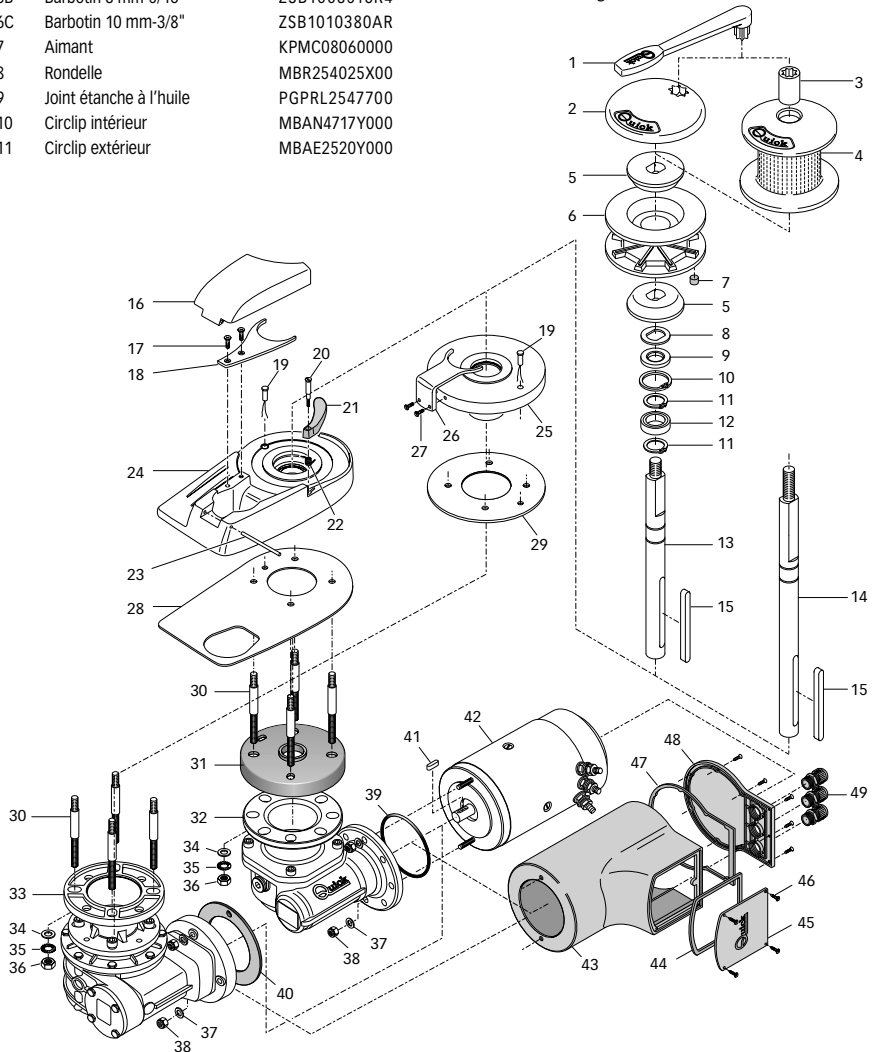



POS.	DENOMINATION	CODE
17A	Vis pour base Aries	MBV0516MXSC0
17B	Vis pour base Flair	MBV0530MXSC0
18A	Dispositif de détachement de chaîne base Aries	MSN10VXP0000
18B	Dispositif de détachement de chaîne base Flair	MSN10VXD0000
19	Capteur de la chaîne	SAKREED00000
20	Vis pour levier de pression	MSMVT1000000
21A	Levier de pression noire	PDLVTD100000
21B	Levier de pression blanche	PDLVTD10W000
22	Ressort pour levier de pression	MMTND1000000
23	Fiche couvercle	MSR10X000000
24A	Base ovale Aries	SGMSC10V0000
24B	Base ovale Flair blanche	SMPD10VW0000
24C	Base ovale Flair noire	SMPD10VB0000
25	Base circulaire	SGMSC10C0000
26	Dispositif de détachement de chaîne Rider	MSN10CX00000
27	Vis pour base Rider	MBV0620MXSC0
28	Joint/gabarit Aries-Flair	PGBSV1000000
29	Joint/gabarit Rider	PGBSC1000000
30A	Goujons base Aries	MBP080807X00
30B	Goujons base Flair	MBP080808X00
31	Joint bride réducteur Top TG50	PGFLRDTG50000
32	Réducteur 700/1000W Quick TG50	SLMR10TG5000
33	Réducteur 1400W	MR1400000000
34	Rondelle	MBR08X000000
35	Grower	MBR08XDE0000
36	Écrous	MBD08MXEN000
37	Rondelle	MBR061815X00
38	Écrous à blocage	MBD06MXET000
39	O-ring	-
40	Joint motoreducteur	PGNP100000000
41	Clavette	MBH050515F00
42A	Moteur électrique 700W 12V	EMF071200000
42B	Moteur électrique 700W 24V	EMF072400000
42C	Moteur électrique 1000W 12V	EMF101200000
42D	Moteur électrique 1000W 24V	EMF102400000
42E	Moteur électrique 1400W 12V	EMF141200000
42F	Moteur électrique 1400W 24V	EMF142400000
43A	Carter 700W	PCCCPM070000
43B	Carter 1000/1400W	PCCCPM100000
44	Presse-étoupe 700/1000/1400W	PCGPMMR00000
45	Couvercle bornier 700/1000/1400W	PCCPPMMR0000
46	Vis	MBV02213AXSC
47	Joint d'embase 700/1000/1400W	PGGPMFN00000
48	Couvercle fond 700/1000/1400W	PCCPPMFN0000
49	Passe-cable	PPM20B000000



ATTENTION: contrôler que le moteur ne soit pas alimenté électriquement lorsqu'on agit sur le guindeau manuellement. Enlever la chaîne ou le cordage du barbotin ou le cordage de la poupée.

Les guindeaux Quick® sont construits avec des matériaux qui résistent bien à l'habitat marin: de toute façon, il est indispensable d'enlever périodiquement les dépôts de sel se formant sur les surfaces externes pour éviter tout effet de corrosion et des dommages à l'appareil.

Laver les surfaces et les pièces où le sel peut se déposer avec de l'eau douce.

Une fois par année, démonter le barbotin et la poupée en procédant dans l'ordre suivant:

VERSION AVEC POUPÉE

A l'aide du levier (1), desserrer la douille (3); enlever la poupée (3) et le cône de l'embrayage supérieur (5); desserrer les vis de fixation (17 ou 27) du dispositif qui libère la chaîne (18 ou 26) et le retirer; enlever le barbotin (6).

VERSION SANS POUPÉE

A l'aide du levier (1), desserrer le couvercle du barbotin (2); enlever le cône de l'embrayage supérieur (5); desserrer les vis de fixation (17 ou 27) du dispositif qui libère la chaîne (18 ou 26) et le retirer; enlever le barbotin (6).

Nettoyer chaque pièce qui a été démontée afin d'éviter tout effet de corrosion et graisser (avec de la graisse marine) le filet de l'arbre (13 ou 14) ainsi que le barbotin (6) où les cônes de l'embrayage appuient (5).

Graisser périodiquement le pivot (23) de le couvercle guide du chaîne (16) (seulement pour guindeau avec base en aluminium).

Enlever toutes traces d'oxyde sur les bornes d'alimentation du moteur électrique et sur celles de la boîte relais; les graisser.

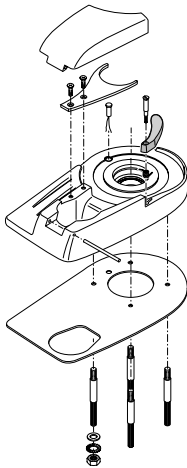
**BASE COMPLETE - ARIES/FLAIR**

	CODE
Base guindeau 700/1000/1400W "ARIES"	ZSBSA010C000
Base guindeau 700/1000/1400W "FLAIR BLACK"	ZSBSFB10C000
Base guindeau 700/1000/1400W "FLAIR WHITE"	ZSBSFW10C000

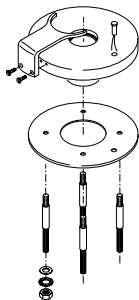
**BASE COMPLETE - RIDER**

	CODE
Base guindeau 700/1000/1400W "RIDER"	ZSBSR010C000

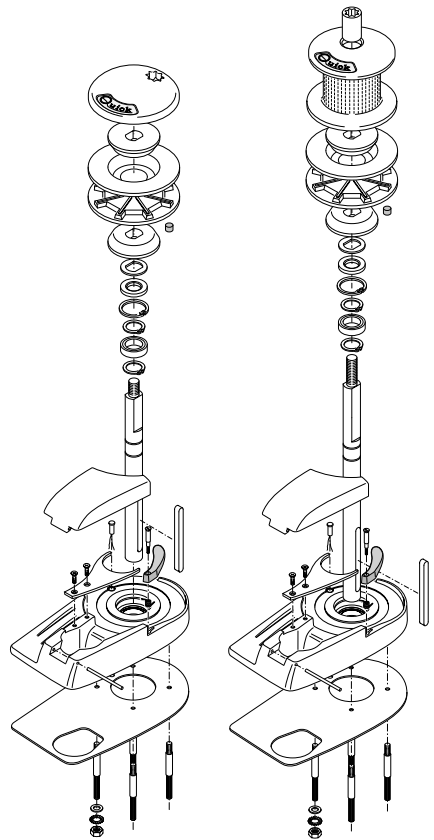
**TOP SANS POUPEE - ARIES/FLAIR**

	CODE
Top série A 7/10/1400W 6 mm	ZSTA01000600
Top série A 7/10/1400W 8 mm-5/16"	ZSTA01000851
Top série A 7/10/1400W 10 mm-3/8"	ZSTA01001038
Top série F Black 7/10/1400W 6 mm	ZSTFB1000600
Top série F Black 7/10/1400W 8 mm-5/16"	ZSTFB1000851
Top série F White 7/10/1400W 6 mm	ZSTFW1000600
Top série F White 7/10/1400W 8 mm-5/16"	ZSTFW1000851

TOP AVEC POUPEE - ARIES/FLAIR

Top série A 7/10/1400W 6mm D	ZSTA010D0600
Top série A 7/10/1400W 8 mm-5/16" D	ZSTA010D0851
Top série A 7/10/1400W 10 mm-3/8" D	ZSTA010D1038
Top série F Black 7/10/1400W 6 mm D	ZSTFB10D0600
Top série F Black 7/10/1400W 8 mm-5/16" D	ZSTFB10D0851
Top série F White 7/10/1400W 6 mm D	ZSTFW10D0600
Top série F White 7/10/1400W 8 mm-5/16" D	ZSTFW10D0851

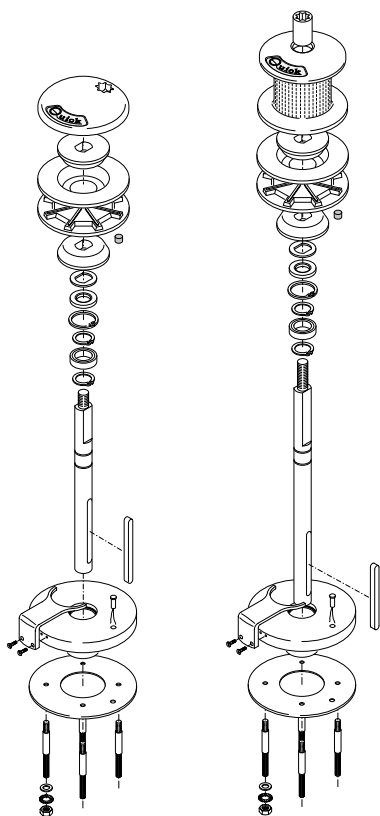
**TOP SANS POUPEE - RIDER**

Top série R 7/10/1400W 6 mm

Top série R 7/10/1400W 8 mm-5/16"

Top série R 7/10/1400W 10 mm-3/8"

TOP AVEC POUPEE - RIDER

Top série R 7/10/1400W 6 mm D

Top série R 7/10/1400W 8 mm-5/16" D

Top série R 7/10/1400W 10 mm-3/8" D

CODE

ZSTR01000600

ZSTR01000851

ZSTR01001038

ZSTR010D0600

ZSTR010D0851

ZSTR010D1038

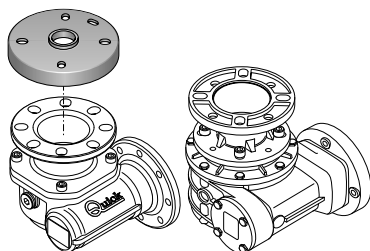
**RÉDUCTEUR - ARIES FLAIR RIDER**

Reducteur 700/1000W - série Quick TG50

Reducteur 1400W

CODE

SLMR10TG5000

MR1400000000

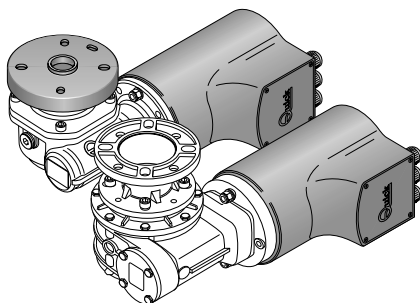
**MOTORÉDUCTEUR - ARIES FLAIR RIDER**

Motoréducteur 700W 12V - Quick

Motoréducteur 1000W 12V - Quick

Motoréducteur 1400W 12V

Motoréducteur 700W 24V - Quick

Motoréducteur 1000W 24V - Quick

Motoréducteur 1400W 24V

CODE

ZSR0712Q0000

ZSR1012Q0000

ZSR141200000

ZSR0724Q0000

ZSR1024Q0000

ZSR142400000

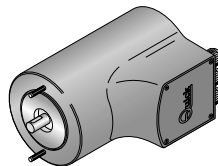
**MOTEUR ÉLECTRIQUE - ARIES FLAIR RIDER**

Moteur électrique 700W 12V

Moteur électrique 1000W 12V

Moteur électrique 1400W 12V

Moteur électrique 700W 24V

Moteur électrique 1000W 24V

Moteur électrique 1400W 24V

CODE

ZSM071200000

ZSM101200000

ZSM141200000

ZSM072400000

ZSM102400000

ZSM142400000



LESEN DES ANKERWINDECODES:

1° BEISPIEL: FLAIR724D

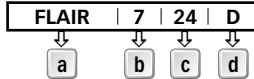

2° BEISPIEL: RIDER1012

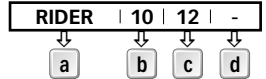

a

Serien name:

- [ARIES] = Oval Basis aus Aluminium
- [FLAIR B] = Oval Basis aus schwarzer GFK
- [FLAIR W] = Oval Basis aus weißer GFK
- [RIDER] = Runde Basis aus Aluminium

b

Motorleistung:

- [7] = 700 W
- [10] = 1000 W
- [14] = 1400 W

c

Motorversorgungsspannung:

- [12] = 12 V
- [24] = 24 V

d

Verholspill:

- [D] = mit Verholspill
- [-] = ohne Verholspill

MODELL	ARIES - / D						FLAIR - / D						RIDER - / D						
MOTORLEISTUNG	W	700		1000		1400		700		1000		1400		700		1000		1400	
Spannung Motor	V	12	24	12	24	12	24	12	24	12	24	12	24	12	24	12	24	12	24
Maximaler Zug	kg	850		1000		1100		850		1000		1100		850		1000		1100	
	lb	1874		2205		2425		1874		2205		2425		1874		2205		2425	
Maximaler Arbeitlast	kg	250	300	370	450	450	500	250	300	370	450	450	500	250	300	370	450	450	500
	lb	551	661	815	992	992	1100	551	661	815	992	992	1100	551	661	815	992	992	1100
Arbeitlast	kg	80	100	120	150	150	170	80	100	120	150	150	170	80	100	120	150	150	170
	lb	176	220	264,5	330,7	330,7	374,8	176	220	264,5	330,7	330,7	374,8	176	220	264,5	330,7	330,7	374,8
Stromaufnahme bei Arbeitlast (1)	A	90	55	140	80	155	85	90	55	140	80	155	85	90	55	140	80	155	85
Maximale Rückholgeschwindigkeit (2)	m/min	27,4	26,4	39,6	40,9	33,0	29,7	27,4	26,4	39,6	40,9	33,0	29,7	27,4	26,4	39,6	40,9	33,0	29,7
	ft/min	90,0	86,6	130,0	134,2	108,0	97,4	90,0	86,6	130,0	134,2	108,0	97,4	90,0	86,6	130,0	134,2	108,0	97,4
Rückholgeschwindigkeit bei Arbeitlast (2)	m/min	14,4	14,8	20,4	21,4	17,5	20,5	14,4	14,8	20,4	21,4	17,5	20,5	14,4	14,8	20,4	21,4	17,5	20,5
	ft/min	47,2	48,6	67,0	70,2	57,4	67,2	47,2	48,6	67,0	70,2	57,4	67,2	47,2	48,6	67,0	70,2	57,4	67,2
Motorkabel-Mindestquerschnitt (3)	mm ²	25	10	35	16	50	25	10	35	16	50	25	10	35	16	50	25	10	35
	AWG	3	7	2	5	0	3	3	7	2	5	0	3	3	7	2	5	0	3
Schutzschalter (4)	A	50	40	80	50	100	50	50	40	80	50	100	50	50	40	80	50	100	50
	kg	17,4	18,5	20,8	22,7	22,7	24,2	16,5	17,6	19,9	21,9	24,2	26,2	16,0	17,1	19,4	21,4	23,4	25,4
Gewicht modell ohne Verholspill	lb	38,4	40,8	45,9	50,0	50,0	53,0	36,4	38,8	43,9	48,3	54,3	58,3	35,3	37,7	42,8	45,8	50,9	55,9
	kg	19,3	20,4	22,7	24,2	24,2	26,2	22,7	24,2	27,7	29,2	31,7	34,2	18,0	19,1	21,4	22,9	25,4	27,9
Gewicht modell mit Verholspill	kg	42,6	45,0	50,0	54,0	54,0	58,0	40,6	43,0	48,1	51,1	56,1	59,1	39,7	42,1	47,2	50,2	55,3	58,3

- (1) Bei gekuppeltem Motor nach der Anlaufphase. • (2) Durchgeführte Messungen mit Kettennuss für 8 mm-Kette.
- (3) Empfohlener Mindestwert für eine gesamtmenge lange L<20m (Siehe Abb. 44). Den Kabelquerschnitt in Abhängigkeit zur Länge des Anschlusses berechnen.
- (4) Mit besonderem Schalter für Gleichstrom (DC) und Verzögerung (Überstrom Schutzautomat oder hydraulischer Schutzautomat).

KETTENNUSSE (*)	6mm	8mm - 5/16"	10mm - 3/8"
Kettengröße	DIN 766 / ISO (**)	DIN 766 / ISO (**)/ G4 / BBB	DIN 766 / ISO (**)/ G4

- (*) Die Codenummern der Kettennüsse finden sich auf der Explosionszeichnung auf S. 32. • (**) ISO EN 818-3.

ABMESSUNGEN mm (inch)	ARIES/FLAIR - / D		RIDER - / D		ARIES/FLAIR - / D	RIDER - / D
	700W	1000W	700W	1000W	1400W	
A	98 (3" 27/32)		100 (3" 15/16)		98 (3" 27/32)	100 (3" 15/16)
B	164 (6" 7/16)		166 (6" 17/32)		164 (6" 7/16)	166 (6" 17/32)
C	141 (5" 9/16)		179 (7")		179 (7")	
D	250 (9" 27/32)		159 (6" 1/4)		250 (9" 27/32)	159 (6" 1/4)
E	141 (5" 9/16)				141 (5" 9/16)	
F	87 (3" 7/16)		Ø 155 (6" 3/32)		87 (3" 7/16)	Ø 155 (6" 3/32)
G	78 (3" 23/32)				78 (3" 23/32)	
H	330 (13")	340 (13" 3/8)	330 (13")	340 (13" 3/8)	385 (15" 1/8)	
I	25 ± 50 mm (31/32" ± 1" 31/32") (5)				30 ± 50 mm (1" 3/32" ± 1" 31/32") (5)	

- (5) Auf Anfrage können Maste und Gewindestifte für stärker Decks geliefert werden.

700 / 1000 / 1400 W ARIES - FLAIR - / D

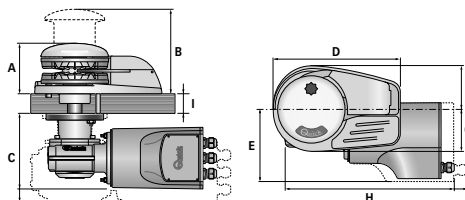

700 / 1000 / 1400 W RIDER - / D

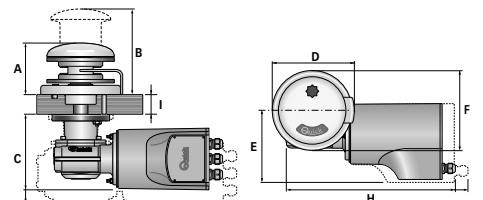

Quick® behält sich das Recht auf Änderungen der technischen Eigenschaften des Geräts und des Inhalts dieses Handbuchs ohne Vorankündigung vor. Bei Fehlern oder eventuellen Unstimmigkeiten zwischen der Übersetzung und dem Ausgangstext ist der Ausgangstext in italienisch oder Englisch maßgeblich.



VOR DEM GEBRAUCH DER ANKERWINDE DIESE BETRIEBSANLEITUNG AUFMERKSAM DURCHLESEN. IM ZWEIFELSFALL WENDEN SIE SICH BITTE AN DEN QUICK®-VERTRAGSHÄNDLER.

- ⚠ **ACHTUNG:** die Quick®-Ankerwinden wurden eigens für das Fieren der Anker entwickelt und hergestellt.
- ⚠ Diese Vorrichtungen für keine anderen Zwecke verwenden. ⚠ Quick® haftet nicht für direkte oder indirekte Schäden, die durch einen unsachgemäßen Gebrauch des Geräts entstehen.
- ⚠ Die Ankerwinde ist nicht darauf ausgelegt, Belastungen unter besonderen Wetterbedingungen (Sturm) standzuhalten.
- ⚠ Die Ankerwinde immer ausschalten, wenn sie nicht benützt wird. ⚠ Vor dem Herunterlassen vom Anker muss sichergestellt werden, dass sich keine Badenden in der Nähe aufhalten. ⚠ Die Verbindung zwischen Tau und Kette muss so klein wie möglich sein, um leicht durch die Führung in der Kettennuss zu laufen. Bei Problemen oder Fragen wenden Sie sich bitte an den Quick® Kundendienst. ⚠ Um für mehr Sicherheit zu garantieren, sollten mindestens zwei Steuerungen für die Ankerwinde installiert werden für den Fall, dass Defekte an einer der Steuerungen auftreten.
- ⚠ Die Kette mit einer Feststellvorrichtung blockieren, bevor man mit dem Boot ausfährt.
- ⚠ Es wird zur Verwendung eines Hauptsicherungsautomaten Quick® zur Motorsicherung geraten.
- ⚠ Die Dose mit den Relaisbox oder den Unpolrelaisbox muss an einem vor Wasser geschützten Ort installiert werden.

DIE PACKUNG ENTHÄLT: Ankerwinde (Top + Untersetzungsgetriebe) - Relaisbox - Basis dichtung - Bohrschablone - Kurbel - Schrauben (für den zusammenbau) - Betriebsanleitung - Garantiebedingungen.

NOTWENDIGE WERKZEUGE FÜR DIE INSTALLATION: Bohrmaschine Bohrer: Ø 9 mm (23/64") und Ø 11 mm (7/16"); Scheibe Ø 53 mm (2"1/16) und Ø 70 mm (2"3/4); Inbusschlüssel: 13 mm.

EMPFOHLENE QUICK®-ZUBEHÖRTEILE: Schalter an Bedientafel (mod. 800) - Wasserdichte Fernbedienung (mod. HRC1002) - Fußschalter (mod. 900) - hydraulischer Schutzautomat - Kettenzähler für Verankerung (mod. CHC1102M und CHC1202M) - Funksteuersystem (mod. 1302, 1352; 02, 302).

VORAUSSETZUNGEN FÜR DIE INSTALLATION: Die Ankerwinde muss so positioniert werden, dass die Kettennuss mit der Bugstütze ausgerichtet ist. Sicherstellen, dass Oberseite und Unterseite vom Deck so parallel wie möglich verlaufen. Falls nicht, die Differenz auf geeignete Weise ausgleichen, da es sonst zu Leistungsverlust am Motor kommen kann. Die Dicke vom Deck muss innerhalb der in der Tabelle angegebenen Wertspannen liegen. Sollte die Dicke nicht mit den angegebenen Werten übereinstimmen, muss mit dem Quick®-Händler Rücksprache gehalten werden. Unter Deck darf es keine Hindernisse geben, die das Durchführen von Kabeln, Tau und Kette behindern. Eine zu geringe Tiefe vom Kabelgatt kann dazu führen, dass sich die Kabel verklemmen.

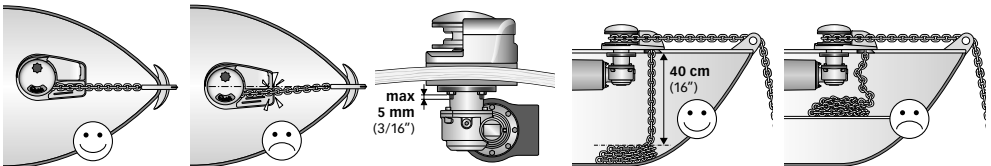

MONTAGE: Nachdem die ideale Position ermittelt worden ist, mithilfe der mitgelieferten Schablone die erforderlichen Löcher bohren. Entfernen Sie überschüssiges Material (Schiffsanstrich, Gelschicht oder zweiteiliges Epoxidharz) vom Kettendurchgang, um freien Durchgang für Seil und Kette sicherzustellen. Den oberen Abschnitt ausrichten; dazu die Dichtung zwischen Deckel und Basis einführen und den unteren Abschnitt durch Einführen der Welle in das Umsetzergetriebe mit dieser verbinden. Die Ankerwinde mit den mitgelieferten Schraubenmuttern an den Sprengringen befestigen. Die Stromkabel der Ankerwinde an den Relaisbox anschließen.

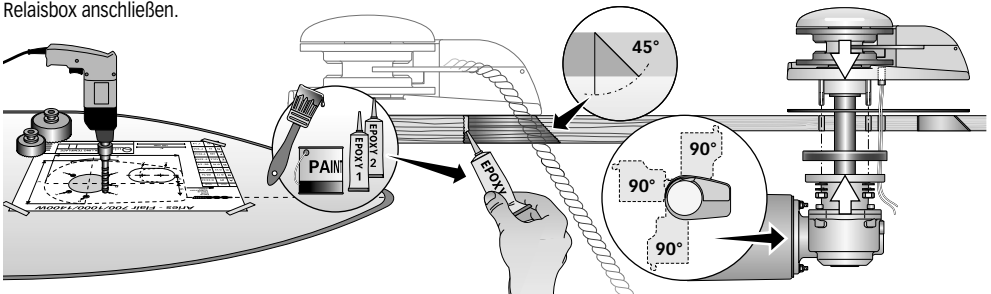

- ⚠ **ACHTUNG:** vor Durchführung des Anschlusses sicherstellen, daß an den Kabeln keine Spannung anliegt.



BASISSYSTEM

ALLGEMEINER
ANSCHLUSSPLAN S. 44

MEHRZWECK-
WASSERDICHTER
FERNBEDIENUNG
MOD. HRC 1002

ANKERWINDE

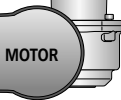
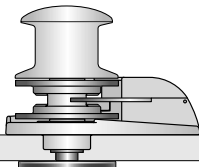

L4

BATTERIE

HYDRAULISCHER
SHUTZAUTOMAT
(Siehe Tabelle
auf S. 28)

L1

L2

M2

L3

RELAISBOX
MOD. T6315-12 (12V)
MOD. T6315-24 (24V)

A2

A1

C

L = (L1) + (L2) + (L3) + (L4)

QUICK®-ZUBEHÖRTEILE FÜR DIE
BETÄTIGUNG DER ANKERWINDE



METERZÄHLER-
FERNBEDIENUNG
FÜR DIE ANKERWINDE

KETTENZÄHLER-
TAFEL



SCHALTER AN
BEDIENTAFEL



FUNKFERNSTEUERUNG

EMPFANGSGERÄT

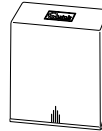

FUNKFERNSENDER

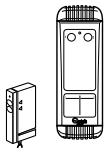

TASCHEN - DRUCKKNOPFSTAFEL

FUSSSCHALTER MOD. 900U UND 900D







SCHWARZ
BRAUN
BLAU

SICHERUNG
4A (12V)
2A (24V)



WICHTIGE HINWEISE

-  **ACHTUNG:** Körperteile oder Gegenstände fern von den Bereichen halten, in denen sich die Kette, Leine und die Kettennuss bewegen. Sicherstellen, daß der elektrische Motor nicht an Spannung liegt, wenn man manuell an der Ankerwinde eingreift (auch dann, wenn man den Hebel zum Lösen der Kupplung verwendet): mit Fernbedienung der Ankerwinde ausgestattete Personen (Fernbedienfeld oder Funksteuerung) könnten die Ankerwinde einschalten.
-  **ACHTUNG:** Die Kette mit einer Feststellvorrichtung blockieren, bevor man mit dem Boot ausfährt.
-  **ACHTUNG:** Die Ankerwinde nicht elektrisch einschalten, wenn der Hebel in der Verholspill oder im Kettennussdeckel eingesetzt ist.
-  **ACHTUNG:** Quick® empfiehlt die Verwendung eines Spezi schalters für Gleichstrom (DC) mit Verzögerung (Wärmeschutzschalter oder Hauptsicherungsautomat) zum Schutz der Stromleitung vom Motor und zum Schutz gegen Überhitzung oder Kurzschlüsse.
Der Schalter kann dazu verwendet werden, um den Steuerschaltkreis der Ankerwinde zu isolieren und so ein versehentliches Einschalten zu verhindern.

GEBRAUCH DER KUPPLUNG

Die Kettennuss (6) ist über die Kupplung (5) fest mit der Hauptwelle (13 oder 14) verbunden. Zum Öffnen (Lösen) der Kupplung (5) dreht man den Hebel (1) in der Buchse der Verholspill oder der Kettennuss (3 oder 2) gegen den Uhrzeigersinn. Dreht man ihn im Uhrzeigersinn, so wird die Kupplung geschlossen (angezogen).

ZUM LICHTEN DES ANKERS

Den Bootmotor einschalten. Sich vergewissern, daß die Kupplung (5) angezogen ist und den Hebel (1) herausziehen. Die UP-Taste an der Ihnen zur Verfügung stehenden Bedientafel drücken.

Falls die Ankerwinde anhält, ohne daß der Schutzautomat (oder thermomagnetische Schalter) ausgelöst wurde, einige Sekunden warten und nochmals probieren (die Taste sollte nicht lange gedrückt werden). Falls der Schutzautomat ausgelöst wurde, den Schalter rückstellen und einige Minuten vor Lichten des Ankers warten.

Falls nach mehreren Versuchen die Ankerwinde weiter blockiert wird, empfehlen wir Ihnen das Boot so manövrieren, um den Anker freizumachen.

Beim lichten der letzten Kettenmeter darauf achten, daß der Bug nicht beschädigt wird.

ZUM SENKEN DES ANKERS

Der Anker kann mit den elektrischen Steuerungen oder von Hand gesenkt werden. Für das manuelle Senken muß man die Kupplung (5) lösen, damit die Kettennuss (6) frei um die eigene Achse dreht und die Kette oder Leine ins Wasser mitzieht. Zum Abbremsen des Falls den Hebel im Uhrzeigersinn drehen.

Für das elektrisch gesteuerte Senken des Ankers muß man die DOWN-Taste an der Bedientafel drücken.

Auf diese Weise wird der Anker kontrolliert gesenkt und die Kette oder Leine gleichmäßig abgewickelt.

Zur Verhinderung von Belastungen an der Ankerwinde muß man die Kette mit einer Feststellrichtung blockieren oder an einer Stelle fest mit einer Leine festmachen, nachdem man sie verankert hat.



POS.	BEZEICHNUNG	CODE
1A	Hebel 700-1000W	MSHD00000000
1B	Hebel 1400W	ZSLMSH000000
2	Kettennussdeckel	MSGB10000R01
3	Buchse	MSD100000R01
4	Verholspill	ZSGMSE100000
5	Kupplungskegel	MSF100000000
6A	Kettennuss 6 mm	ZSB100600000
6B	Kettennuss 8 mm-5/16"	ZSB1008516R4
6C	Kettennuss 10 mm-3/8"	ZSB1010380AR
7	Magnet	KPMC08060000
8	Grower	MBR254025X00
9	Ölabdichtung	PGPRL2547700
10	Sprengring	MBAN4717Y000
11	Sprengring	MBAE2520Y000
12	Lager	MBJ60052RS10
13	Kurze Welle	MSAS10274R30

POS.	BEZEICHNUNG	CODE
14	Lange Welle	MSAS10308R30
15	Keil	MBH080780F00
16A	Abdeckung Kettenführung A	SGMSGG100000
16B	Abdeckung Kettenführung aus weißer Flair	PDGC10DW0000
16C	Abdeckung Kettenführung aus schwarzer Flair	PDGC10DB0000

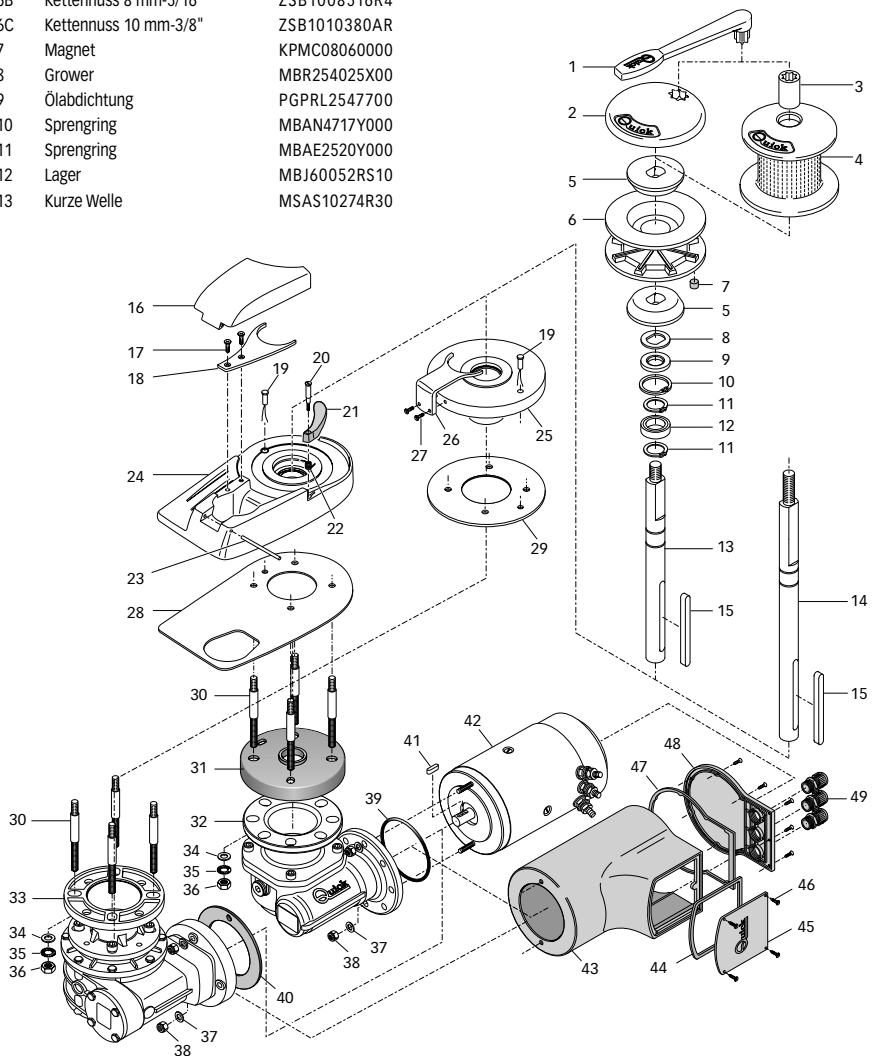



POS.	BEZEICHNUNG	CODE
17A	Schraub mit Basis aus Aries	MBV0516MXSC0
17B	Schraub mit base Basis aus F	MBV0530MXSC0
18A	Kettenabweiser mit Basis A	MSN10VXP0000
18B	Kettenabweiser mit Basis F	MSN10VXD0000
19	Meterzählsensor	SAKREED00000
20	Schraub mit controll-hebel	MSMVT1000000
21A	Controll-hebel schwarze	PDLVTD100000
21B	Controll-hebel weiß	PDLVTD10W000
22	Feder mit controll-hebel	MMTND1000000
23	Stecker	MSR10X000000
24A	Basisteil Aries	SGMSC10V0000
24B	Basisteil weiß Flair	SMPD10VW0000
24C	Basisteil schwarzer Flair	SMPD10VB0000
25	Basisteil Rider	SGMSC10C0000
26	Kettenabweiser mit Rider Basis	MSN10CX00000
27	Schraub	MBV0620MXSC0
28	Dichtung/A-F Schablone	PGBSV1000000
29	Dichtung/R Schablone	PGBSC1000000
30A	Stiftschrauben Basis Aries	MBP080807X00
30B	Stiftschrauben Basis Flair	MBP080808X00
31	Dichtung Getriebeflansch Top TG50	PGFLRDGT50000
32	Untersetzungsgetriebe 700/1000W Quick TG50	SLMR10TG5000
33	Untersetzungsgetriebe 1400W	MR14000000000
34	Paßscheib	MBR08X000000
35	Grower	MBR08XDE0000
36	Muttern	MBD08MXEN000
37	Paßscheib	MBR061815X00
38	Sicherungsmutter	MBD06MXET000
39	O-ring	-
40	Dichtung Untersetzungsgetriebe	PGNP100000000
41	Keil	MBH050515F00
42A	Elektromotor 700W 12V	EMF071200000
42B	Elektromotor 700W 24V	EMF072400000
42C	Elektromotor 1000W 12V	EMF101200000
42D	Elektromotor 1000W 24V	EMF102400000
42E	Elektromotor 1400W 12V	EMF141200000
42F	Elektromotor 1400W 24V	EMF142400000
43A	Motorgehäuse Wasserdichter 700W	PCCCPM070000
43B	Motorgehäuse Wasserdichter 1000/1400W	PCCCPM100000
44	Bodensichtung Anschlussleiste 700/1000/1400W	PCGPMR00000
45	Deckel Klemmleiste 700/1000/1400W	PCCPPMMR0000
46	Schraub	MBV02213AXSC
47	Bodendichtung 700/1000/1400W	PGGPMFN00000
48	Unterer Deckel 700/1000/1400W	PCCPPMFN0000
49	Wasserdichte Kabeldurchführung	PPM20B000000



ACHTUNG: sicherstellen, daß der elektrische Motor nicht an Spannung liegt, wenn man manuell an der Ankerwinde eingreift. Sorgfältig die Kette oder Leine vom Kettennuss oder die Leine von der Verholspill nehmen.

Die Quick®-Ankerwinden werden aus seewasserfestem Material hergestellt. Dennoch muß man regelmäßig Salzablagerung an den Außenflächen entfernen, um Korrosion und folglich Schäden am Gerät zu vermeiden. Sorgfältig mit Süßwasser die Oberflächen und die Teile, an denen sich Salz ablagern kann, waschen.

Einmal jährlich das Kettennuss und die Verholspill ausbauen. Dabei die folgende Reihenfolge beachten:

VERSION MIT VERHOLSPILL

Mit dem Hebel (1) die Buchse (3) lösen. Die Verholspill (4) und den oberen Kupplungskegel (5) herausnehmen. Die Befestigungsschrauben (17 oder 27) der Kettenabweiser (18 oder 26) lösen und entfernen. Das Kettennuss (6) ausbauen.

VERSION OHNE VERHOLSPILL

Mit dem Hebel (1) den Kettennussdeckel (2) entriegeln. Den oberen Kupplungskegel (5) herausziehen. Die Befestigungsschrauben (17 oder 27) der Kettenabweiser (18 oder 26) lösen und entfernen. Das Kettennuss (5) ausbauen.

Alle ausgebauten Teile kontrollieren, um eventuelle Korrosion festzustellen. Das Gewinde der Welle (13 oder 14) und die Kettennuss (6) an der Stelle, an der die Kupplungskegel (5) aufliegen, schmieren (mit seewasserfestem Schmierfett) .

Regelmäßig den Bolzen (23) der Abdeckung Kettenführung (16) (nur für Ankerwinden mit Aluminiumbasis).

Eventuelle Oxydation an den Versorgungsklemmen des elektrischen Motors und an denen des Relaisbox mit den Schützen beseitigen. Mit Schmierfett schmieren.

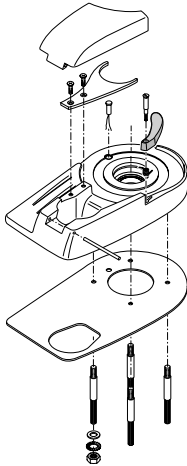
**BASIS KOMPLETT - ARIES/FLAIR**

CODE

Basis Ankerwinde 700/1000/1400W "ARIES" ZSBSA010C000

Basis Ankerwinde 700/1000/1400W "FLAIR BLACK" ZSBSFB10C000

Basis Ankerwinde 700/1000/1400W "FLAIR WHITE" ZSBSFW10C000

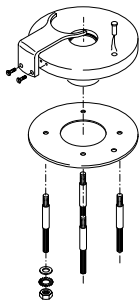
**BASIS KOMPLETT - RIDER**

CODE

Basis Ankerwinde 700/1000/1400W "RIDER" ZSBSR010C000

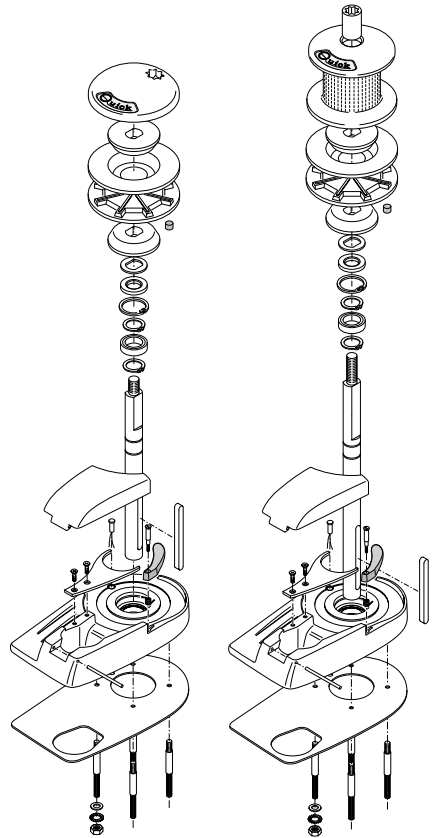
**TOP OHNE VERHOLSPILL - ARIES/FLAIR**

CODE

Top Serie A 7/10/1400W 6 mm ZSTA01000600

Top Serie A 7/10/1400W 8 mm-5/16" ZSTA01000851

Top Serie A 7/10/1400W 10 mm-3/8" ZSTA01001038

Top Serie F Black 7/10/1400W 6 mm ZSTFB1000600

Top Serie F Black 7/10/1400W 8 mm-5/16" ZSTFB1000851

Top Serie F White 7/10/1400W 6 mm ZSTFW1000600

Top Serie F White 7/10/1400W 8 mm-5/16" ZSTFW1000851

TOP MIT VERHOLSPILL - ARIES/FLAIR

Top Serie A 7/10/1400W 6mm D ZSTA010D0600

Top Serie A 7/10/1400W 8 mm-5/16" D ZSTA010D0851

Top Serie A 7/10/1400W 10 mm-3/8" D ZSTA010D1038

Top Serie F Black 7/10/1400W 6 mm D ZSTFB10D0600

Top Serie F Black 7/10/1400W 8 mm-5/16" D ZSTFB10D0851

Top Serie F White 7/10/1400W 6 mm D ZSTFW10D0600

Top Serie F White 7/10/1400W 8 mm-5/16" D ZSTFW10D0851

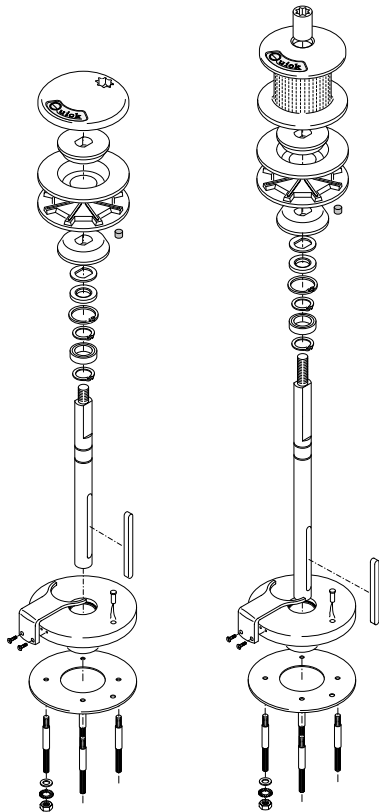

TOP OHNE VERHOLSPILL - RIDER

- Top Serie R 7/10/1400W 6 mm
- Top Serie R 7/10/1400W 8 mm-5/16"
- Top Serie R 7/10/1400W 10 mm-3/8"

TOP MIT VERHOLSPILL - RIDER

- Top Serie R 7/10/1400W 6 mm D
- Top Serie R 7/10/1400W 8 mm-5/16" D
- Top Serie R 7/10/1400W 10 mm-3/8" D

CODE

- ZSTR01000600
- ZSTR01000851
- ZSTR01001038

- ZSTR010D0600
- ZSTR010D0851
- ZSTR010D1038

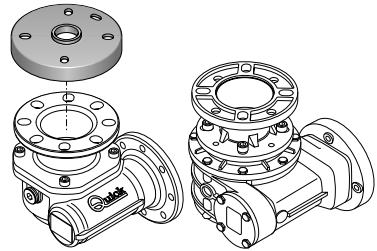

GETRIEBE - ARIES FLAIR RIDER

- Getriebe 700/1000W - Serie Quick TG50
- Getriebe 1400W

CODE

- SLMR10TG5000
- MR1400000000

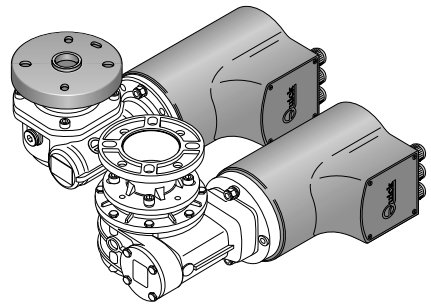

UNTERSETZUNGSGETRIEBE - ARIES FLAIR RIDER

- | | |
|---|--------------|
| Untersetzungsgetriebe 700W 12V - Quick | ZSR0712Q0000 |
| Untersetzungsgetriebe 1000W 12V - Quick | ZSR1012Q0000 |
| Untersetzungsgetriebe 1400W 12V | ZSR141200000 |
| Untersetzungsgetriebe 700W 24V - Quick | ZSR0724Q0000 |
| Untersetzungsgetriebe 1000W 24V - Quick | ZSR1024Q0000 |
| Untersetzungsgetriebe 1400W 24V | ZSR142400000 |

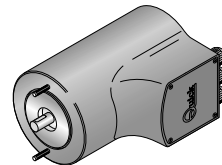

ELEKTROMOTOR - ARIES FLAIR RIDER

- | | |
|------------------------|--------------|
| Elektromotor 700W 12V | ZSM071200000 |
| Elektromotor 1000W 12V | ZSM101200000 |
| Elektromotor 1400W 12V | ZSM141200000 |
| Elektromotor 700W 24V | ZSM072400000 |
| Elektromotor 1000W 24V | ZSM102400000 |
| Elektromotor 1400W 24V | ZSM142400000 |

CODE



CÓMO SE LEE EL CÓDIGO DEL MOLINETE:

1º EJEMPLO: FLAIR724D

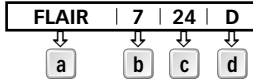

2º EJEMPLO: RIDER1012

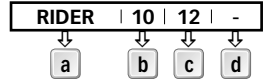

a

Nombre de la serie:

[**ARIES**] = base oval de aluminio
 [**FLAIR B**] = base oval de fibra negra
 [**FLAIR W**] = base oval de fibra blanca
 [**RIDER**] = base circular de aluminio

b

Potencia motor:

[**7**] = 700 W
 [**10**] = 1000 W
 [**14**] = 1400 W

c

Tensión alimentación

motor:
 [**12**] = 12 V
 [**24**] = 24 V

d

Campana:

[**D**] = con campana
 [-] = sin campana

MODELO	ARIES - / D						FLAIR - / D						RIDER - / D						
POTENCIA MOTOR	W	700		1000		1400		700		1000		1400		700		1000		1400	
Tensión alimentación motor	V	12	24	12	24	12	24	12	24	12	24	12	24	12	24	12	24	12	24
Tiro instantáneo máximo	kg	850		1000		1100		850		1000		1100		850		1000		1100	
	lb	1874		2205		2425		1874		2205		2425		1874		2205		2425	
Carico di lavoro massimo	kg	250	300	370	450	450	500	250	300	370	450	450	500	250	300	370	450	450	500
	lb	551	661	815	992	992	1100	551	661	815	992	992	1100	551	661	815	992	992	1100
Carga de trabajo	kg	80	100	120	150	150	170	80	100	120	150	150	170	80	100	120	150	150	170
	lb	176	220	264.5	330.7	330.7	374.8	176	220	264.5	330.7	330.7	374.8	176	220	264.5	330.7	330.7	374.8
Absorción de corriente al carico di lavoro (1)	A	90	55	140	80	155	85	90	55	140	80	155	85	90	55	140	80	155	85
Velocità max di recupero (2)	m/min	27,4	26,4	39,6	40,9	33,0	29,7	27,4	26,4	39,6	40,9	33,0	29,7	27,4	26,4	39,6	40,9	33,0	29,7
	ft/min	90,0	86,6	130,0	134,2	108,0	97,4	90,0	86,6	130,0	134,2	108,0	97,4	90,0	86,6	130,0	134,2	108,0	97,4
Velocità di recupero a la carga de trabajo (2)	m/min	14,4	14,8	20,4	21,4	17,5	20,5	14,4	14,8	20,4	21,4	17,5	20,5	14,4	14,8	20,4	21,4	17,5	20,5
	ft/min	47,2	48,6	67,0	70,2	57,4	67,2	47,2	48,6	67,0	70,2	57,4	67,2	47,2	48,6	67,0	70,2	57,4	67,2
Sección mínima cables motor (3)	mm²	25	10	35	16	50	25	25	10	35	16	50	25	25	10	35	16	50	25
	AWG	3	7	2	5	0	3	3	7	2	5	0	3	3	7	2	5	0	3
Interruptor de protección (4)	A	50	40	80	50	100	50	50	40	80	50	100	50	50	40	80	50	100	50
Peso modelo sin campana	kg	17,4		18,5		20,8		16,5		17,6		19,9		16,0		17,1		19,4	
	lb	38,4		40,8		45,9		36,4		38,8		43,9		35,3		37,7		42,8	
Peso modelo con campana	kg	19,3		20,4		22,7		22,7		18,4		19,5		18,0		19,1		21,4	
	lb	42,6		45,0		50,0		40,6		43,0		48,1		39,7		42,1		47,2	

- (1) Después de un primer periodo de utilización. • (2) Medidas efectuadas con barboten para cadena de 8 mm.
- (3) Valor mínimo aconsejado para una longitud total L<20m (ver pag. 44). Calcular la sección del cable en función de la longitud de la conexión.
- (4) Con interruptor específico para corrientes continuas (DC) y retraso (magneto-térmico o magneto-hidráulico).

BARBOTEN (*)	6mm	8mm - 5/16"	10mm - 3/8"
Cadena suportada	DIN 766 / ISO (**)	DIN 766 / ISO (**)/ G4 / BBB	DIN 766 / ISO (**)/ G4

- (*) Para los códigos de los barbotenes consultar el despiece de pag. 40. • (**) ISO EN 818-3.

DIMENSIONES mm (inch)	ARIES/FLAIR - / D		RIDER - / D		ARIES/FLAIR - / D		RIDER - / D	
	700W	1000W	700W	1000W	1400W			
A	98 (3" 27/32)		100 (3" 15/16)		98 (3" 27/32)		100 (3" 15/16)	
B	164 (6" 7/16)		166 (6" 17/32)		164 (6" 7/16)		166 (6" 17/32)	
C	141 (5" 9/16)		179 (7")					
D	250 (9" 27/32)		159 (6" 1/4)		250 (9" 27/32)		159 (6" 1/4)	
E			141 (5" 9/16)					
F	87 (3" 7/16)		Ø 155 (6" 3/32)		87 (3" 7/16)		Ø 155 (6" 3/32)	
G	78 (3" 23/32)				78 (3" 23/32)			
H	330 (13")	340 (13" 3/8)	330 (13")	340 (13" 3/8)	385 (15" 1/8)			
I	25 ± 50 mm (31/32" ± 1" 31/32") (3)				30 ± 50 mm (1" 3/32 ± 1" 31/32") (3)			

- (5) Bajo petición se pueden suministrar ejes y prisioneros para espesores de cubierta mayores.

700 / 1000 / 1400 W ARIES - FLAIR - / D

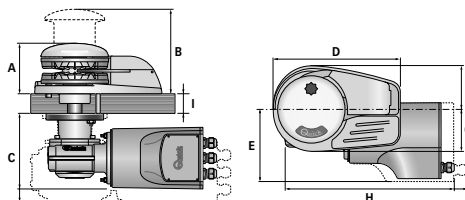

700 / 1000 / 1400 W RIDER - / D

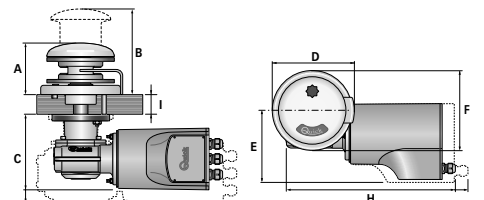

Quick® se reserva el derecho de aportar modificaciones en las características técnicas del aparato y en el contenido de este manual sin obligación de avisar previamente. En caso de discordancias o eventuales errores entre el texto traducido y el texto original en italiano, remitirse al texto en italiano o en inglés.



ANTES DE UTILIZAR EL MOLINETE LEER CON ATENCIÓN EL PRESENTE MANUAL DE INSTRUCCIONES. EN CASO DE DUDA CONSULTAR CON EL CONCESIONARIO VENDEDOR QUICK®.

- ⚠ **ATENCIÓN:** los molinetes Quick® han sido proyectados y realizados para llevar las anclas. ⚠ No utilizar estos aparatos para otros tipos de operaciones. ⚠ Quick® no asume ningún tipo de responsabilidad por daños directos o indirectos causados por una utilización inadecuada del aparato. ⚠ El molinete no ha sido diseñado para soportar cargas generadas en condiciones atmosféricas especiales (borrasca). ⚠ Desactivar siempre el molinete cuando no se use. ⚠ Asegurarse de que no hayan personas bañándose cerca antes de soltar el ancla. ⚠ La ensambladura entre el cabo y la cadena debe ser de dimensiones reducidas para poder desplazarse fácilmente dentro del perfil del barboten. Ante cualquier inconveniente o necesidad contactar con el servicio de asistencia Quick®. ⚠ Para más seguridad, si un accionamiento se daña, aconsejamos instalar al menos dos accionamientos para el manejo del molinete. ⚠ Bloquear la cadena con un retén antes de salir a navegar. ⚠ Aconsejamos el uso del interruptor magneto-hidráulico Quick® como seguridad para el motor. ⚠ La caja de telerruptores o teleinvertidores debe instalarse en un lugar protegido de posibles entradas de agua.

LA REFERENCIA CONTIENE: molinete (top + motoreductor) - caja telerruptores - guarnición de la base - plantilla - palanca - tornillos (para el ensamblaje) - manual del usuario - condiciones de garantía.

HERRAMIENTAS NECESARIAS PARA LA INSTALACIÓN: taladro con brocas: $\varnothing 9$ mm (23/64") y $\varnothing 11$ mm (7/16"); de taza $\varnothing 53$ mm (2"1/16) y $\varnothing 70$ mm (2"3/4); llave hexagonal: 13 mm.

ACCESORIOS ACONSEJADOS POR QUICK®: mando de panel (mod. 800) - Tablero de pulsadores hermético (mod. HRC 1002) - Mando de pie (mod. 900) - Interruptor magneto-hidráulico - Cuenta-cadena para el anclaje (mod. CHC 1102M y CHC 1202M) - Sistema de accionamiento vía radio (mod. 1302, 1352; 02, 302).

REQUISITOS PARA LA INSTALACIÓN: el molinete se posiciona alineando el barboten con la punta de la proa. Verificar que las superficies superior e inferior de la cubierta sean lo más paralelas posibles; si eso no sucede compensar oportunamente la diferencia (la falta de paralelismo puede causar pérdidas de potencia del motor). No pueden existir obstáculos debajo de la cubierta para el pasaje de los cables, cabo y cadena; si no hay una buena profundidad debajo de la cubierta se pueden crear obstrucciones. El espesor de la cubierta tendrá que ser comprendido entre los valores indicados en el tablero. Si hay espesores diferentes es necesario consultar al revendedor Quick®.

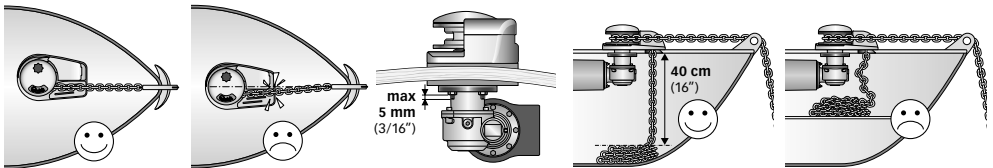

PROCEDIMIENTO DE MONTAJE: establecida la posición ideal, hacer los agujeros utilizando la plantilla que tiene en dotación. Remover el exceso de material del agujero donde pasa la cadena, alisarlos con un producto específico (pintura marina, gel o resina epoxidica) en modo de asegurar el libre pasaje del cabo y de la cadena. Posicionar la parte superior, introduciendo la guarnición entre la cubierta y la base y conectar a esta la parte inferior, introduciendo el árbol del motor en el reductor. Fijar el molinete apretando las tuercas en los prisioneros de bloqueo. Conectar los cables de alimentación que proceden del molinete al telerruptor.

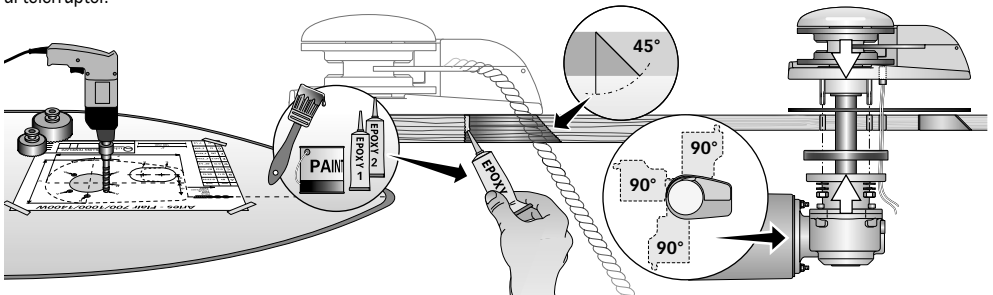

- ⚠ **ATENCIÓN:** antes de efectuar la conexión asegurarse de que no esté presente la alimentación en los cables.





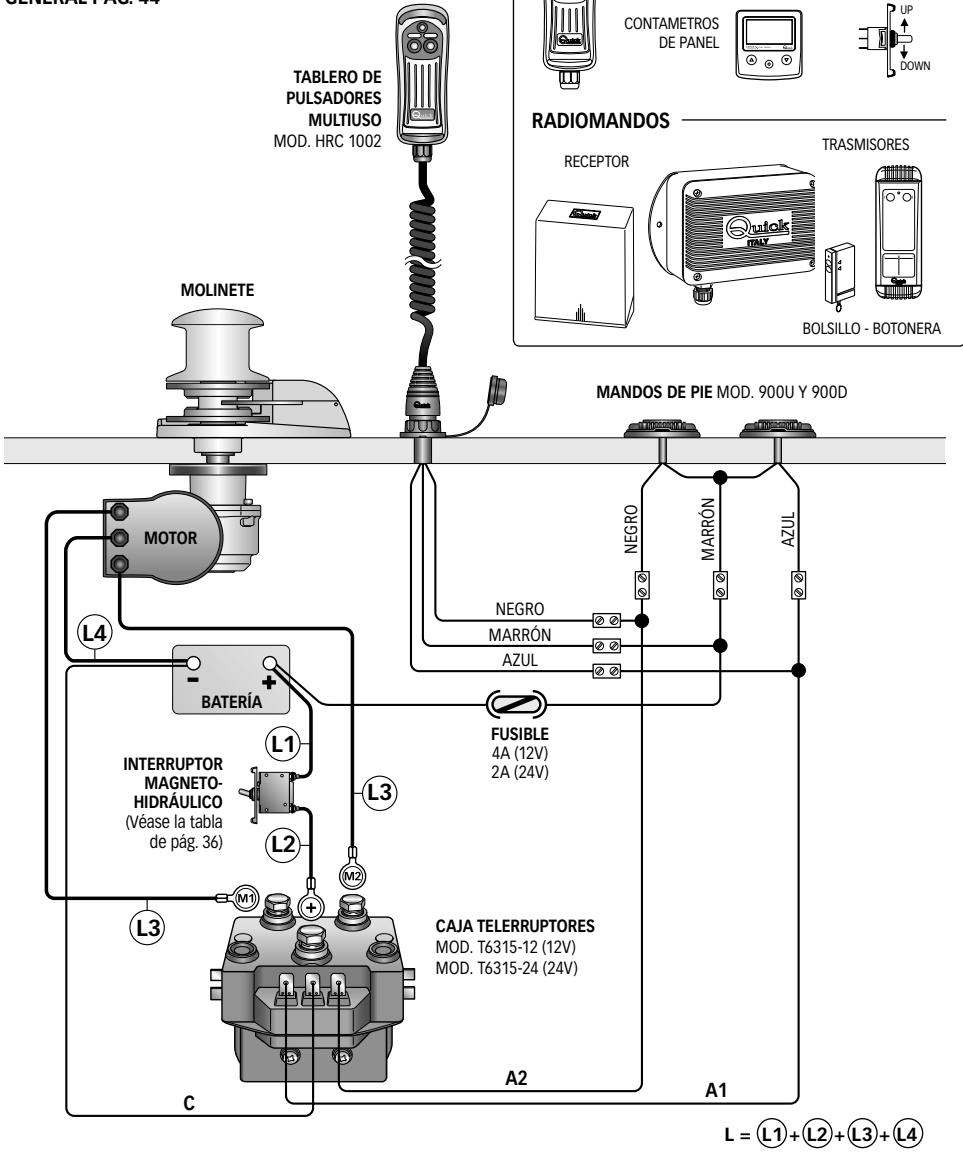

SISTEMA BASE

DIAGRAMA DE CONEXIÓN
GENERAL PÁG. 44





ADVERTENCIAS IMPORTANTES

-  **ATENCIÓN:** no acercar partes del cuerpo u objetos a la zona donde deslizan la cadena, el cabo y el barboten. Asegurarse de que no esté presente la alimentación en el motor eléctrico cuando se obra manualmente en el molinete (tampoco cuando se utilice la palanca para aflojar el embrague); de hecho, personas equipadas con mando a distancia del molinete (tablero de pulsadores remoto o radiomando) podrían activarlo accidentalmente.
-  **ATENCIÓN:** bloquear la cadena con un retén antes de salir a navegar.
-  **ATENCIÓN:** no activar eléctricamente el molinete con la palanca introducida en la campana o en la tapa del barboten.
-  **ATENCIÓN:** Quick® aconseja utilizar un interruptor específico para corrientes continuas (DC) y retrasado (magneto-térmico o magneto-hidráulico) para proteger la línea del motor de recalentamientos o cortocircuitos. El interruptor puede utilizarse para aislar el circuito de accionamiento del molinete evitando de esta manera accionamientos accidentales.

UTILIZACIÓN DEL EMBRAGUE

El barboten (6) está unido con el eje principal (13 ó 14) mediante el embrague (5). El embrague se abre (desenganche) utilizando la palanca (1) que, introducida en la brújula de la campana o en la tapa del barboten (3 ó 2) deberá girar en sentido anti-horario. Girando en sentido horario se provocará el cierre (enganche) del embrague.

PARA LEVAR ANCLAS

Encender el motor de la embarcación. Asegurarse de que el embrague (5) esté apretado y extraer la palanca (1). Presionar el pulsador UP del mando a vuestra disposición.

Si el molinete se para sin que el interruptor magneto-hidráulico (o magnetotérmico) haya saltado, esperar algunos segundos y volver a probar (evitar presionar continuamente el pulsador).

Si el interruptor magnetotérmico ha saltado, volver a activar el interruptor y esperar algunos minutos antes de volver a levar anclas.

Si después de varios intentos el molinete continúa a bloquearse, aconsejamos maniobrar la embarcación para desencallar el ancla.

Controlar la subida de los últimos metros de cadena para evitar que se estropee la proa.

PARA FONDEAR

El tendido del ancla se puede efectuar mediante mandos eléctricos o manualmente. Para efectuar la operación manualmente es necesario abrir el embrague (5) dejando libre el barboten (6) de manera que pueda girar sobre su propio eje y arrastrar la cadena o el cabo al agua.

Para frenar la caída del ancla es necesario girar la palanca (1) en sentido horario.

Para tender el ancla eléctricamente es necesario presionar el pulsador DOWN del mando a vuestra disposición. De esta manera la bajada de la misma se podrá controlar perfectamente y el desenrollado de la cadena o del cabo será regular.

Para evitar solicitaciones en el molinete, una vez anclados, bloquear la cadena con un retén o fijarla en un punto estable con un cabo.



POS.	DENOMINACIÓN	CÓDIGO
1A	Palanca 700-1000W	MSHD00000000
1B	Palanca 1400W	ZSLMSH000000
2	Tapa barboten	MSGB10000R01
3	Brújula	MSD10000R01
4	Campana	ZSGMSE100000
5	Cono embrague	MSF100000000
6A	Barboten 6 mm	ZSB100600000
6B	Barboten 8 mm-5/16"	ZSB1008516R4
6C	Barboten 10 mm-3/8"	ZSB1010380AR
7	Imán	KPMC08060000
8	Arandelas	MBR254025X00
9	Sello de aceite	PGPRL2547700
10	Seeger	MBAN4717Y000
11	Seeger	MBAE2520Y000

POS.	DENOMINACIÓN	CÓDIGO
12	Cojinete	MBJ60052RS10
13	Eje corto	MSAS10274R30
14	Eje largo	MSAS10308R30
15	Chaveta	MBH080780F00
16A	Tapa guía cadenas A	SGMSGG100000
16B	Tapa guía cadenas F blanca	PDGC10DW0000
16C	Tapa guía cadenas F negra	PDGC10DB0000

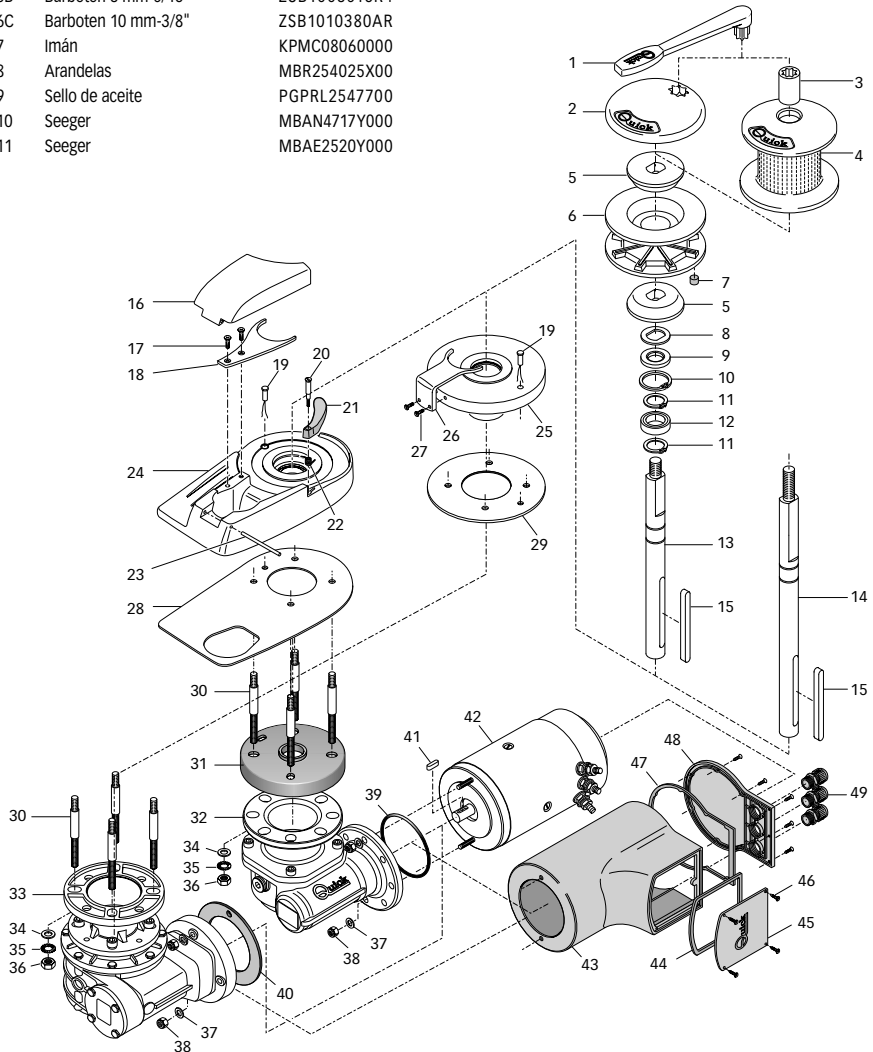



POS.	DENOMINACIÓN	CÓDIGO
17A	Tornillo base Aries	MBV0516MXSC0
17B	Tornillo base Flair	MBV0530MXSC0
18A	Separa-cadena base Aries	MSN10VXP0000
18B	Separa-cadena base Flair	MSN10VXD0000
19	Sensor cuenta-metros	SAKREED00000
20	Pasador	MSMVT1000000
21A	Pestaña negra	PDLVTD1000000
21B	Pestaña blanca	PDLVTD10W0000
22	Muelle por pestaña	MMTND1000000
23	Clavija	MSR10X0000000
24A	Base oval Aries	SGMSC10V0000
24B	Base oval Flair blanca	SMPD10VW00000
24C	Base oval Flair negra	SMPD10VB00000
25	Base circular	SGMSC10C00000
26	Separa-cadena per base Rider	MSN10CX000000
27	Tornillo base Rider	MBV0620MXSC0
28	Guarnición/plantilla Aries-Flair	PGBSV10000000
29	Guarnición/plantilla Rider	PGBSC10000000
30A	Prisioneros base Aries	MBP080807X00
30B	Prisioneros base Flair	MBP080808X00
31	Guarnición brida reductor Top TG50	PGFLRDTG50000
32	Reductor 700/1000W Quick TG50	SLMR10TG50000
33	Reductor 1400W	MR14000000000
34	Arandelas	MBR08X0000000
35	Grower	MBR08XDE00000
36	Tuercas	MBD08MXEN000
37	Arandelas	MBR061815X00
38	Tuercas autobloqueantes	MBD06MXET000
39	O-ring	-
40	Guarnición motoreductor	PGNP100000000
41	Chaveta	MBH050515F00
42A	Motor eléctrico 700W 12V	EMF0712000000
42B	Motor eléctrico 700W 24V	EMF0724000000
42C	Motor eléctrico 1000W 12V	EMF1012000000
42D	Motor eléctrico 1000W 24V	EMF1024000000
42E	Motor eléctrico 1400W 12V	EMF1412000000
42F	Motor eléctrico 1400W 24V	EMF1424000000
43A	Carcasa 700W	PCCCPM0700000
43B	Carcasa 1000/1400W	PCCCPM1000000
44	Guarnición caja de conexiones 700/1000/1400W	PCGPMMR000000
45	Tapa caja de conexiones 700/1000/1400W	PCCPPMMR00000
46	Tornillo	MBV02213AXSC
47	Guarnición posterior 700/1000/1400W	PGGPMFN000000
48	Tapa posterior 700/1000/1400W	PCCPPMFN000000
49	Pasacables	PPM20B0000000



ATENCIÓN: asegurarse de que no esté presente la alimentación en el motor eléctrico cuando se actúa manualmente en el molinete; quitar con precaución las cadenas o cabo del barboten o el cabo de la campana.

Los molinetes Quick® están contruidos con materiales resistentes al ambiente marino; de todas formas, es indispensable eliminar periódicamente los depósitos de sal que se forman sobre las superficies externas para evitar oxidaciones que consiguientemente estropearían el aparato. Lavar con agua dulce las superficies y aquellas partes donde podría haberse depositado la sal.

Desmontar una vez al año el barboten y la campana ateniéndose a la secuencia siguiente:

VERSIÓN CON CAMPANA

Con la palanca (1) desatornillar la brújula (3); extraer la campana (4) y el cono embrague superior (5); desatornillar los tornillos de fijación (17 o 27) del dispositivo de desenganche de la cadena (18 o 26) y quitarlo; extraer el barboten (6).

VERSIÓN SIN CAMPANA

Con la palanca (1) desatornillar la tapa del barboten (6); extraer el cono del embrague superior (5); desatornillar los tornillos de fijación (17 o 27) del dispositivo de desenganche de la cadena (18 o 26) y quitarlo; extraer el barboten (6).

Limpiar cada una de las piezas desmontadas para que no se verifiquen oxidaciones y engrasar (con grasa marina) la rosca del eje (13 ó 14) y el barboten (6) donde apoyan los conos del embrague (5).

Engrasar periódicamente el perno (23) de la tapa guía cadenas (16) (sólo para molinetes con base de aluminio).

Eliminar los eventuales depósitos de óxido de los bornes de alimentación del motor eléctrico y los de la caja telerruptores; después engrasarlos.

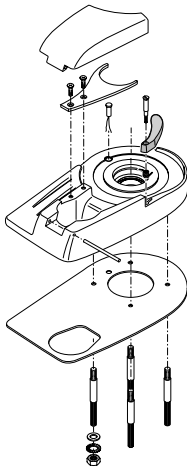
**BASE COMPLETA - ARIES/FLAIR**

	CÓDIGO
Base molinete 700/1000/1400W "ARIES"	ZSBSA010C000
Base molinete 700/1000/1400W "FLAIR BLACK"	ZSBSFB10C000
Base molinete 700/1000/1400W "FLAIR WHITE"	ZSBSFW10C000

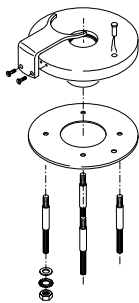
**BASE COMPLETA - RIDER**

	CÓDIGO
Base molinete 700/1000/1400W "RIDER"	ZSBSR010C000

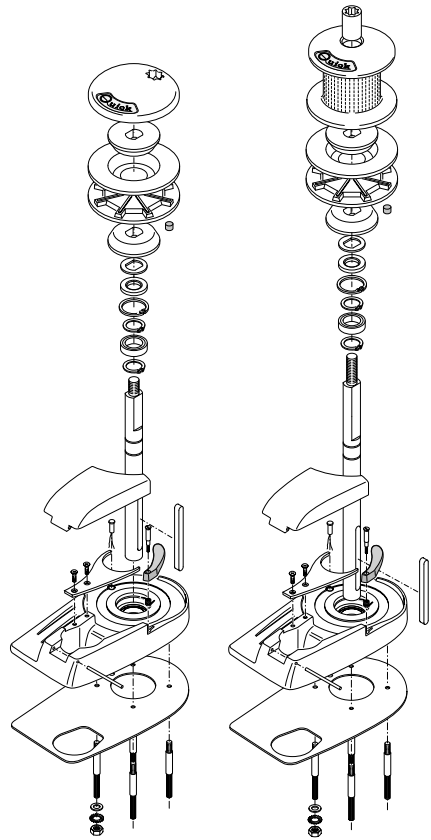
**TOP SIN CAMPANA - ARIES/FLAIR**

	CÓDIGO
Top serie A 7/10/1400W 6 mm	ZSTA01000600
Top serie A 7/10/1400W 8 mm-5/16"	ZSTA01000851
Top serie A 7/10/1400W 10 mm-3/8"	ZSTA01001038
Top serie F Black 7/10/1400W 6 mm	ZSTFB1000600
Top serie F Black 7/10/1400W 8 mm-5/16"	ZSTFB1000851
Top serie F White 7/10/1400W 6 mm	ZSTFW1000600
Top serie F White 7/10/1400W 8 mm-5/16"	ZSTFW1000851

TOP CON CAMPANA - ARIES/FLAIR

Top serie A 7/10/1400W 6mm D	ZSTA010D0600
Top serie A 7/10/1400W 8 mm-5/16" D	ZSTA010D0851
Top serie A 7/10/1400W 10 mm-3/8" D	ZSTA010D1038
Top serie F Black 7/10/1400W 6 mm D	ZSTFB10D0600
Top serie F Black 7/10/1400W 8 mm-5/16" D	ZSTFB10D0851
Top serie F White 7/10/1400W 6 mm D	ZSTFW10D0600
Top serie F White 7/10/1400W 8 mm-5/16" D	ZSTFW10D0851

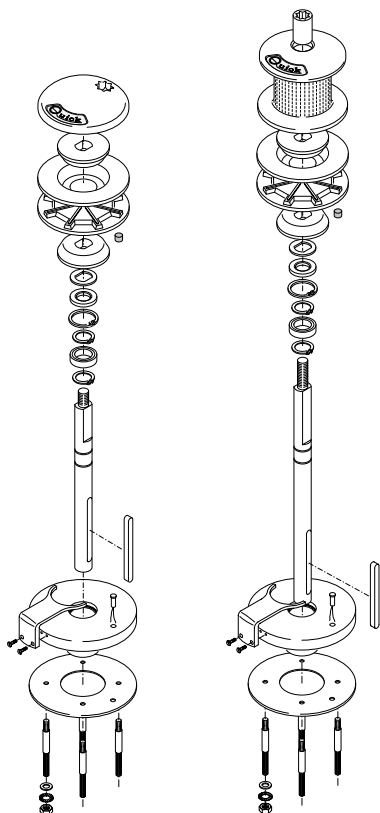
TOP SIN CAMPANA - RIDER

Top serie R 7/10/1400W 6 mm

Top serie R 7/10/1400W 8 mm-5/16"

Top serie R 7/10/1400W 10 mm-3/8"

TOP CON CAMPANA - RIDER

Top serie R 7/10/1400W 6 mm D

Top serie R 7/10/1400W 8 mm-5/16" D

Top serie R 7/10/1400W 10 mm-3/8" D

CÓDIGO

ZSTR01000600

ZSTR01000851

ZSTR01001038

ZSTR010D0600

ZSTR010D0851

ZSTR010D1038

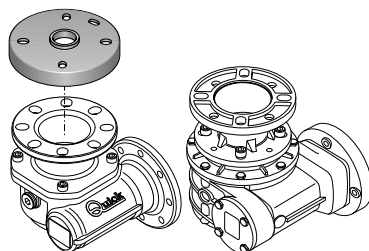
REDUCTOR - ARIES FLAIR RIDER

Reductor 700/1000W - serie Quick TG50

Reductor 1400W

CÓDIGO

SLMR10TG5000

MR1400000000

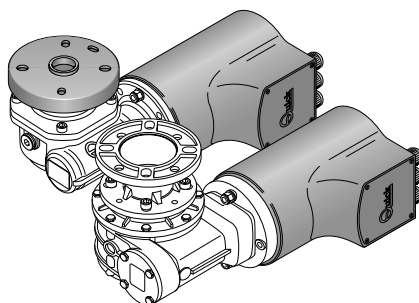
MOTOREDUCTOR - ARIES FLAIR RIDER

Motoreductor 700W 12V - Quick

Motoreductor 1000W 12V - Quick

Motoreductor 1400W 12V

Motoreductor 700W 24V - Quick

Motoreductor 1000W 24V - Quick

Motoreductor 1400W 24V

CÓDIGO

ZSR0712Q0000

ZSR1012Q0000

ZSR141200000

ZSR0724Q0000

ZSR1024Q0000

ZSR142400000

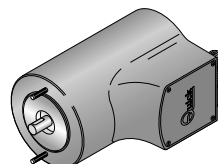
MOTOR ELÉCTRICO - ARIES FLAIR RIDER

Motor eléctrico 700W 12V

Motor eléctrico 1000W 12V

Motor eléctrico 1400W 12V

Motor eléctrico 700W 24V

Motor eléctrico 1000W 24V

Motor eléctrico 1400W 24V

CÓDIGO

ZSM071200000

ZSM101200000

ZSM141200000

ZSM072400000

ZSM102400000

ZSM142400000

MAIN CONNECTION DIAGRAM

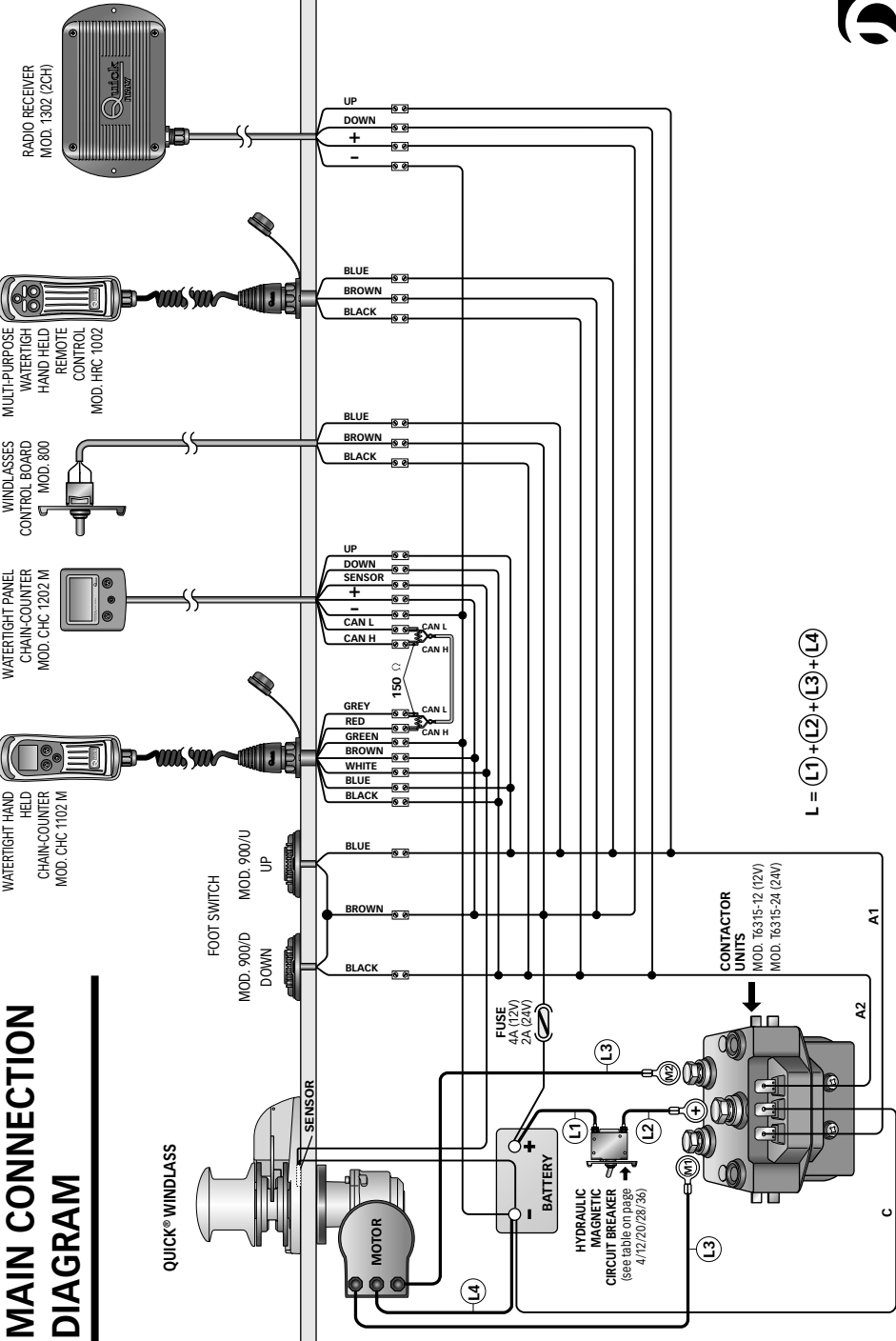

ARIES FLAIR RIDER

700/1000/1400W

R009B

IT Codice e numero seriale del prodotto

GB Product code and serial number

FR Code et numéro de série du produit

DE Code- und Seriennummer des Produkts

ES Código y número de serie del producto

Quick[®]
Nautical Equipment

QUICK[®] SRL - Via Piangipane, 120/A - 48100 Piangipane (RAVENNA) - ITALY
Tel. +39.0544.415061 - Fax +39.0544.415047
www.quickitaly.com - E-mail: quick@quickitaly.com