

Mass Combi Pro

12/3000-150, 24/3500-100

MULTI PURPOSE CHARGER INVERTER



EN
NL
DE
FR
ES
IT

USER'S AND INSTALLATION MANUAL

Zie www.mastervolt.com/combi

Siehe www.mastervolt.com/combi

Voir www.mastervolt.com/combi

Vea www.mastervolt.com/combi

Vedere www.mastervolt.com/combi

1000010915/01

MASTERVOLT
THE POWER TO BE INDEPENDENT

OVERVIEW MASS COMBI PRO

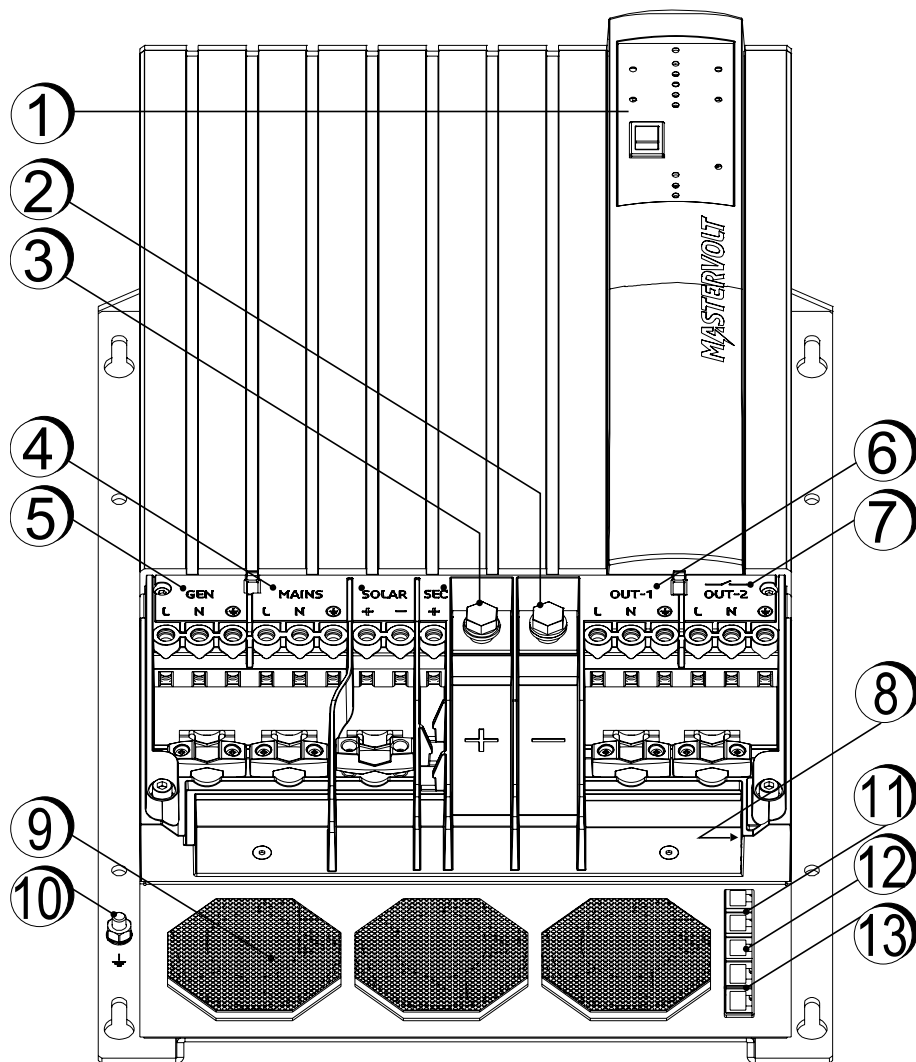

Figure 0-1: Overview of the Mass Combi Pro

- | | | |
|--|-------------------------------------|----------------------------------|
| 1. Display with front switch | 6. AC output 1 ("OUT-1") | 11. Sync connector (2x) |
| 2. Main battery negative | 7. AC output 2 ("OUT-2") (switched) | 12. Temperature sensor connector |
| 3. Main battery positive | 8. DIP switch units (2x8) | 13. MasterBus connector (2x) |
| 4. Mains AC input terminal ("MAINS") | 9. Fan (3x) | |
| 5. Generator AC input terminal ("GEN") | 10. Ground stud | |

TABLE OF CONTENTS:

OVERVIEW MASS COMBI PRO	2
1 GENERAL INFORMATION.....	5
1.1 Product description.....	5
1.2 Use of this manual.....	5
1.3 Validity of this manual.....	5
1.4 Scope of warranty.....	5
1.5 Liability	5
1.6 Changes to the Mass Combi Pro.....	5
1.7 Identification label.....	5
2 SAFETY GUIDELINES AND WARNINGS.....	6
2.1 Warnings and symbols	6
2.2 Use for intended purpose	6
2.3 Organizational measures.....	6
2.4 Warning of special dangers	6
2.5 General safety and installation precautions.....	6
2.6 Warning regarding life support applications.....	7
2.7 Warning regarding the use of batteries.....	7
3 HOW IT WORKS.....	8
3.1 Principle.....	8
3.2 Battery charger	8
3.3 Inverter	9
3.4 Operation modes.....	9
4 OPERATION	12
4.1 LED indicators	12
4.2 Protections	13
4.3 Operation policies.....	13
4.4 Maintenance.....	14
4.5 Daily use, MasterBus monitoring.....	14
5 INSTALLATION	15
5.1 Unpacking	15
5.2 Environment	15
5.3 Wiring	15
5.4 Things you need	16
5.5 Removal of the front lid.....	16
5.6 Mounting the cabinet to a surface.....	17
5.7 Wiring instructions	17
5.8 Installation overview	18
5.9 Setting up a MasterBus network.....	19
5.10 How to set up a MasterBus network.....	19
6 CONFIGURATION	20
6.1 Configuration via DIP-switches.....	20
6.2 MasterBus configuration	21
7 COMMISSIONING, DECOMMISSIONING	24
7.1 Commissioning	24
7.2 Decommissioning	24
7.3 Trouble shooting.....	24

8	TECHNICAL DATA	26
8.1	Specifications	26
8.2	Correct disposal of this product	27
8.3	Dimensions.....	28
9	ORDERING INFORMATION	29

1 GENERAL INFORMATION

1.1 Product description

The Mass Combi Pro is a multifunctional charger inverter. It passes through power from an external AC source (e.g. a generator or shore power connection) to your AC loads and charges your main batteries.

1.2 Use of this manual

Copyright © 2015 Mastervolt. All rights reserved.
Reproduction, transfer, distribution or storage of part or all of the contents in this document in any form without the prior written permission of Mastervolt is prohibited.

This manual serves as a guideline for the safe and effective use and installation of the Mass Combi Pro, also called Combi Pro further in this manual:

- For the installer this manual gives directions for the installation, operation and commissioning.
- For the end user this manual gives directions for the operation, maintenance and possible correction of minor malfunctions.
- Every person who works with the device should be familiar with the contents of this manual, and must carefully follow the instructions contained herein.
- Store the manual in an accessible place.

1.3 Validity of this manual

This manual is valid for the following models:

Part no	Model
38513000	Mass Combi Pro 12/3000-150
38523500	Mass Combi Pro 24/3500-100

All the specifications, provisions and instructions contained in this manual apply solely to the Mastervolt-delivered standard version of a single Mass Combi Pro.

1.4 Scope of warranty

Mastervolt assures the product warranty of the Mass Combi Pro during two years after purchase, on the condition that all instructions and warnings given in this manual are taken into account during installation and operation.

Among other things, this means that installation is carried out by a qualified electrician, that installation and maintenance are executed according to the stated instructions and correct working sequence, and that no changes or repairs may have been performed on the Mass Combi Pro other than by Mastervolt. The warranty is limited to the costs of repair and/or replacement of the product by Mastervolt only.

Costs for installation labour, shipping of the defective parts and indirect damage are not covered by this warranty. For making an appeal on warranty you can contact your supplier directly, stating your complaint, application, date of purchase and part number / serial number.

1.5 Liability

Mastervolt accepts no liability for:

- consequential damage due to use of the Mass Combi Pro;
- possible errors in the manuals and the results thereof.

1.6 Changes to the Mass Combi Pro

Changes to the Mass Combi Pro may be carried out only after obtaining the written permission of Mastervolt. This is not applicable for DIP-switches which are used for user settings.

1.7 Identification label



Figure 1-1: Example of an identification label

The identification label is positioned at the right side of the Mass Combi Pro, see figure 1-1.



CAUTION!

Never remove the identification label.

2 SAFETY GUIDELINES AND WARNINGS

2.1 Warnings and symbols

Safety instructions and warnings are marked in this manual and on the product by the following pictograms:



A procedure, circumstance, etc which deserves extra attention.



CAUTION!

Special information, commands and prohibitions in order to prevent damage.



WARNING

A WARNING refers to possible injury to the user or installer or significant material damage to the Soladin if the installer / user does not (carefully) follow the stated procedures.



Read this manual before installation and use



This product has been declared conform the EC directives and standards.

IP23

Degree of protection: IP23. The product is protected against touch by fingers and water spray < 60 degrees from vertical.



Safety class 1. This product must be provided with an equipment grounding conductor to the AC-output ground terminal

2.2 Use for intended purpose

- 1 The Mass Combi Pro is constructed as per the applicable safety-technical guidelines.
- 2 Use the Mass Combi Pro only:
 - for the charging of batteries and the supply of loads attached to these batteries, in permanent systems;
 - for the conversion of battery DC voltage to AC voltage;
 - when connected to a dedicated double pole circuit breaker and RCD;
 - with fuses, protecting the Mass Combi Pro AC and DC wiring;
 - in a technically correct condition;
 - in a closed, well-ventilated room, protected against rain, moist, dust and condensation;
 - after observing the instructions in the user's manual.



WARNING

Never use the Mass Combi Pro in situations where there is danger of gas or dust explosion or potentially flammable products!

- 3 Use of the Mass Combi Pro other than mentioned in point 2 is considered to be inconsistent with the intended purpose. Mastervolt does not hold itself liable for any damage resulting from the above.

2.3 Organizational measures

The user must always:

- have access to the user's manual;
- be familiar with the contents of this manual. This applies in particular to Chapter 2 "Safety Guidelines and Measures".

2.4 Warning of special dangers

- 1 If the Mass Combi Pro is switched off during maintenance and/or repair activities, it should be secured against unexpected and unintentional switching on:
 - Remove the AC supply.
 - Remove the connection to the batteries.
 - Be sure that others cannot reverse the measures taken.
- 2 If maintenance and repairs are required, use only original spare parts.

2.5 General safety and installation precautions

- Do not expose the Mass Combi Pro to rain, snow, spray, moisture, excessive pollution and condensing circumstances. To reduce risk of fire hazard, do not cover or obstruct the ventilation openings. Do not install the Mass Combi Pro in a non-ventilated area, overheating results.
- The Mass Combi Pro must be provided with an equipment grounding conductor to the AC-input ground terminal. Grounding and all other wiring must comply with local rules and regulations.
- In case of fire, you must use a fire extinguisher which is appropriate for electrical equipment.
- Short circuiting or reversing polarity will lead to serious damage to batteries, Mass Combi Pro and wiring. Fuses between batteries and Mass Combi Pro cannot prevent damage caused by reversed polarity and warranty will be void.
- Protect all DC wiring with a proper fuse, according to the guidelines in this manual.
- Connection and protection must be done in accordance with local standards.
- Do not work on the Mass Combi Pro or system if it is still connected to a power source. Only allow changes in your electrical system to be carried out by qualified electricians.

- Check the wiring and connections at least once a year. Defects such as loose connections, burnt cables etc. must be corrected immediately.
- Do not touch the equipment when wet or with clammy hands.
- Not only the batteries, but the Mass Combi Pro as well can become a projectile if your vehicle is involved in an accident! Ensure adequate and secure mounting and always use suitable transportation handling equipment.
- Except for the connection compartment, see section 5.5, the cabinet of the Mass Combi Pro must not be opened. There are no serviceable parts inside the cabinet. Only qualified, allowed and trained electricians are authorized to open the connection compartment.

2.6 Warning regarding life support applications

The Mass Combi Pro products are not sold for applications in any medical equipment intended for use as a component of any life support system unless a specific written agreement pertaining to such intended use is executed between the manufacturer and Mastervolt. Such agreement will require the equipment manufacturer either to contract additional reliability testing of the Mass Combi Pro parts and/or to commit to undertake such testing as a part of the manufacturing process. In addition the manufacturer must agree to indemnify and not hold Mastervolt responsible for any claims arising from using Mass Combi Pro parts for life support equipment.

2.7 Warning regarding the use of batteries

Excessive battery discharge and/or high charging voltages can cause serious damage to batteries. Do not exceed the recommended limits of your batteries. Avoid short circuiting batteries, as this may result in explosion and fire hazard. Installation of the batteries and adjustments of the Mass Combi Pro should only be undertaken by authorised personnel!

3 HOW IT WORKS

The Mass Combi Pro is a multifunctional charger inverter. It combines an inverter, a battery charger and an AC transfer switch.

3.1 Principle

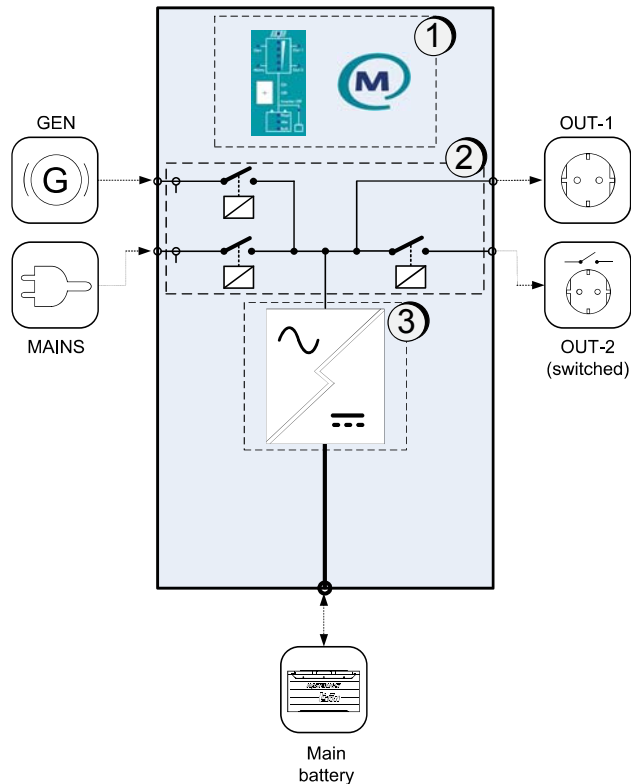

Figure 3-1: Working principle of the Mass Combi Pro

3.1.1 User interface (1)

The Mass Combi Pro user interface consists of a front switch with status LEDs and MasterBus communication.

3.1.2 AC transfer switch (2)

This part of the Mass Combi Pro regulates the AC energy flow through the device. The generator ("GEN") and mains ("MAINS") input are switched, as is AC output 2 ("OUT-2"). All AC is connected to the inverter (3). If the MAINS plug is disconnected and the Generator is not running, the inverter takes over using battery power to provide AC power.

3.1.3 Inverter/ Main charger (3)

This part converts the AC power to DC for charging of the main battery and it inverts the DC power from the battery to supply AC to Output 1 and 2. ("OUT-1" and "OUT-2").

3.2 Battery charger

The built-in battery charger is electronically controlled. It is designed for optimal recharging of lead acid (flooded, gel, AGM) and Li-ion batteries. Battery charging via AC or Solar input is accomplished with Mastervolt's 3-Step Plus charging algorithm. With an external AC source connected, the Mass Combi Pro charger also serves the functions of an AC to DC converter to supply DC loads which are connected to the batteries. Simple, automatic operation is enabled by the microprocessor that is the brain of the inverter/charger combination.

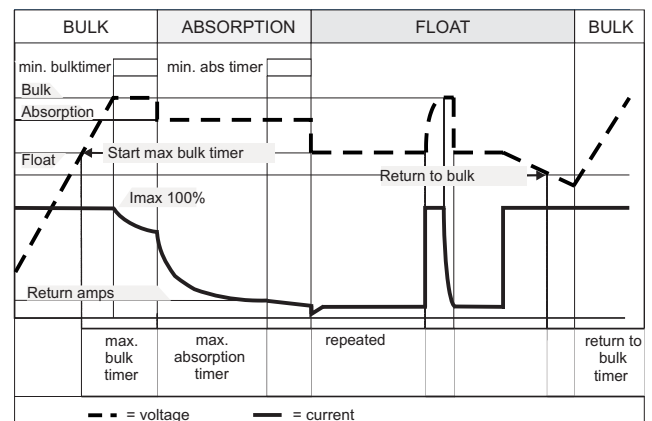

Figure 3-2: Three step Plus charge system

3.2.1 Three step Plus charge system

See figure 3-2. The first step of the three step Plus charge system is the BULK phase, in which the output current of the charger is 100%, and the greater part of the battery capacity is charged rapidly. The current charges the batteries and gradually the voltage rises to the absorption voltage, refer to the specifications. The duration of this phase depends on the ratio of battery capacity to charger current, the loads connected and the degree to which the batteries were discharged to begin with.

The bulk phase is followed by the absorption phase. Absorption charging ends when the battery is completely full. Battery voltage remains constant throughout this stage and the charge current decreases during charging of the battery. With flooded batteries this stage lasts some four hours, with gel and AGM around three. Once the battery is 100% full or when the maximum absorption timer has passed, the charger automatically switches over to the float phase.

During the float phase the Mass Combi Pro switches to Float voltage, refer to the specifications, and stabilises this voltage to maintain the batteries in an optimum condition. Connected DC-loads are powered directly by the charger. If the load is higher than charger capacity, the required additional power comes from the battery, which will be progressively discharged until the charger automatically switches back to the bulk phase. Once consumption

decreases, the charger goes back to normal operation of the three-step charge system.

As the Mass Combi Pro is equipped with a three-step Plus charge system, the batteries can also remain connected to the Mass Combi Pro in winter. One hour every 12 days the charger automatically switches to the Bulk phase to keep the battery working properly and prolong its life span. The three-step Plus charge system is also safe for all the connected equipment.

3.2.2 Temperature compensated charging

The Mass Combi Pro is delivered with a battery temperature sensor. By installing this battery temperature sensor (for Lead Acid batteries only) the charge voltages are automatically adapted for deviating temperatures. When the battery temperature is low, the charge voltage increases. On the other hand, when the battery temperature is high, the charge voltage is decreased. Overcharge and gassing are prevented this way. This will extend the life of your batteries.



Temperature compensated charging can not prevent the batteries from overcharging situations.

3.2.3 Silent mode

When the Mass Combi Pro is in operation, the cooling fans produce audible noise. In silent mode the noise level is reduced. As a result:

- the charge current may be limited;
- the charging time may increase.

3.3 Inverter

3.3.1 General

The inverter provides voltage and frequency regulated AC power from a battery bank. Fast acting electronic circuits protect the inverter against extreme overloads, low and high battery voltage and overheating of the inverter.

A large momentary surge power is available for inductive loads, such as electric motors.

3.3.2 Energy saving mode (selectable)

In the inverter mode the Mass Combi Pro has a built-in automatic energy saving feature that reduces battery power consumption when no load is present on the outputs. Response from idle is instant. In most cases the operation is not noticeable. The energy saving mode can be set by means of MasterBus or dipswitch A4, refer to chapter 6, Configuration.

The Mass Combi Pro scans the AC outputs with pulses of 230 V every 2½ seconds. When it detects a load that is larger than 50 W (adjustable), it switches On the inverter automatically.



Small loads such as clocks in VCR's or micro waves are most likely not to work in this mode.

3.4 Operation modes

The Mass Combi Pro is not just a combination of an inverter and a battery charger. Many additional features help to increase the total available AC power. In the next sections, nine different main operation modes are described. Most of these modes can be combined, refer to section 3.4.10. You can enable these modes by means of either front switch, DIP switches or the MasterBus user interface. All modes are enabled by default except for the Gen/Mains supporting mode as there are regulations in some countries that do not allow this. After enabling by the user, becoming "active" of a mode is determined by the Mass Combi Pro itself based on AC and DC power availability, battery state of charge and configuration (Chapter 6, Configuration).

3.4.1 Inverting mode

See figure 3-3. When there is no external AC power available, the inverter of the Mass Combi Ultra provides AC power on the AC outputs.

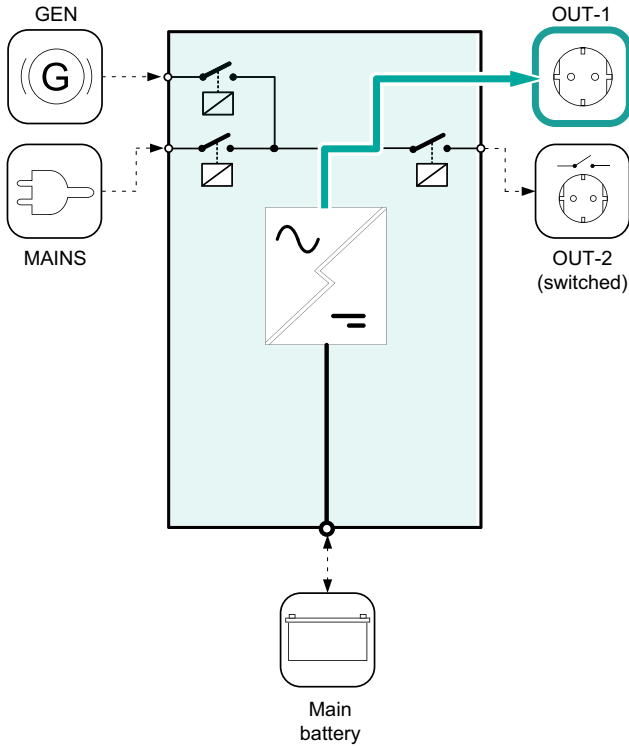

Figure 3-3: Inverting mode

3.4.2 Charging mode

See figure 3-4 and 3-5. When external AC power comes available on the Mains- or Gen input, the main battery will be charged and the AC outputs are supplied by the external power.

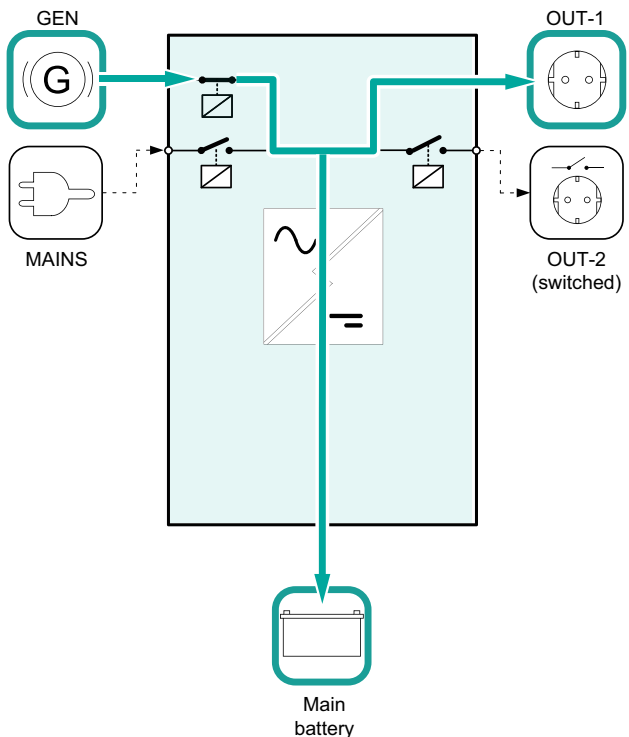

Figure 3-4: AC power from Generator input

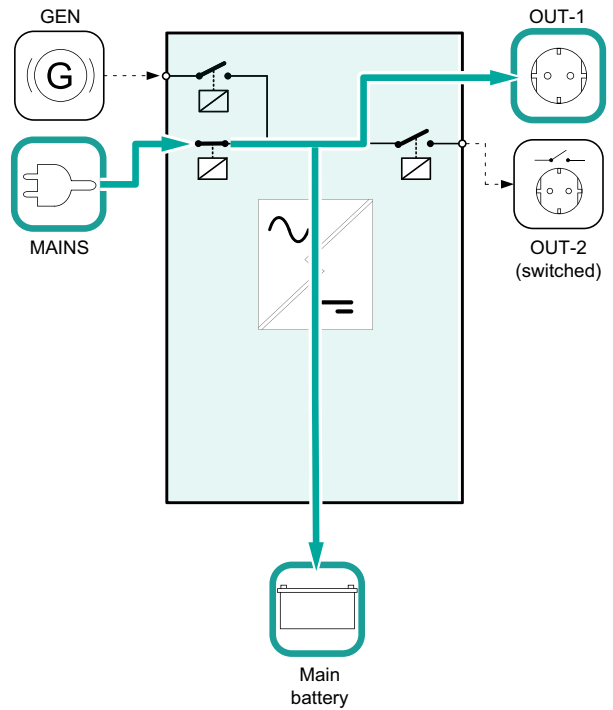

Figure 3-5: AC power from Mains input

3.4.3 Output 1 and 2

See figure 3-6. The Mass Combi ultra has two AC-outputs. AC-power is always available on output 1 and this is the ideal output for loads that need continuous AC-power. Output 2 is only available when external AC power comes available on the Mains- and/or Gen input. Output 2 policy is configurable by the dipswitches locally on the Mass Combi Ultra or a Masterbus monitoring device. (See chapter 4.3.2).

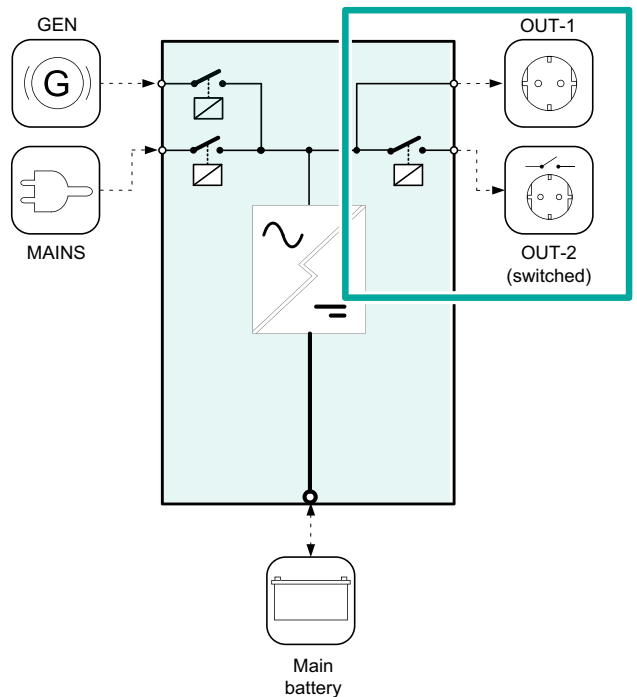

Figure 3-6: Out-1 and Out-2

3.4.4 Power sharing mode

See figure 3-7. If the available power at the AC-input is limited, and the load connected to the AC output increases, the external AC circuit breaker may trip if nothing is done. To avoid this, the Mass Combi Ultra can automatically reduce the battery charger output, and thus the AC power consumption. This Power sharing feature constantly senses the incoming AC current which is used to supply both the battery charger and the appliances connected to the AC outputs.

The Power Sharing level should be set to match the value of the external circuit breaker, which protects the incoming AC power. For example, when the external AC power is limited by a 6 A fuse, the Power Sharing level must be set to 6 A. When the total connected AC load reaches the level of the Power Sharing setting (6 A), there will be no power left over to charge the battery. This means that the charge current of the Mass Combi will be reduced to 0 A.

The Power Sharing level can be adjusted by means of the DIP-switches locally on the Mass Combi Ultra. However, we recommend the use optional remote control, like the Masterview Easy.

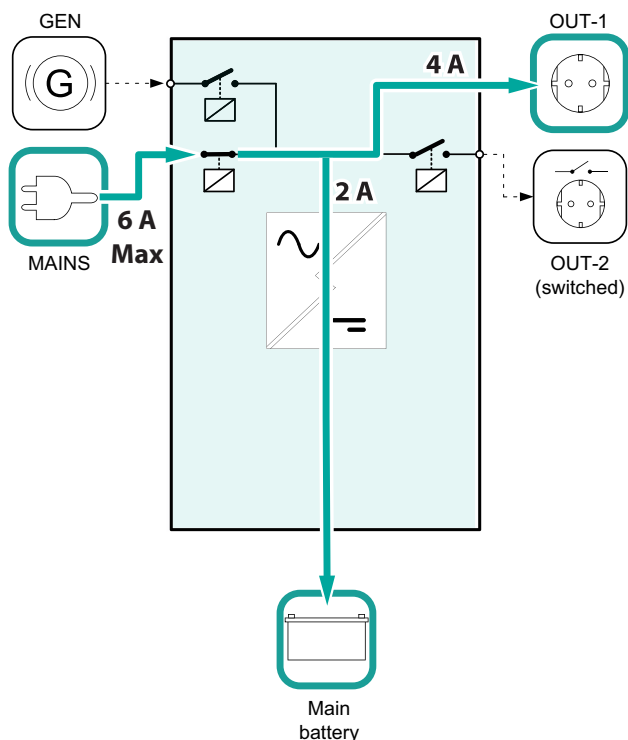

Figure 3-7: Power Sharing level is set to a 6 A while the AC outputs consume a total of 4 Amps. This means that $6 - 4 = 2$ A is left over for charging.

3.4.5 Gen-/Mains support

See figure 3-8. If the demand for AC power is higher than the available power at the AC-input, the external AC circuit breaker may trip if nothing is done. This problem can be solved by the Generator / mains support function. With the Generator / mains support mode enabled, the inverter will operate in parallel with the external AC power source. This means that energy from the batteries is added to the AC-output only.

Under no circumstances AC power from the inverter can be fed back into the AC grid. Please mind that several countries maintain different regulations with regard to AC-sources operating in parallel with the AC-grid. This may mean that in some situations the use of the Generator / Mains support function is not allowed. Please acquaint yourself with local regulations on this issue. Never use the Generator / Mains support mode if this is not allowed!

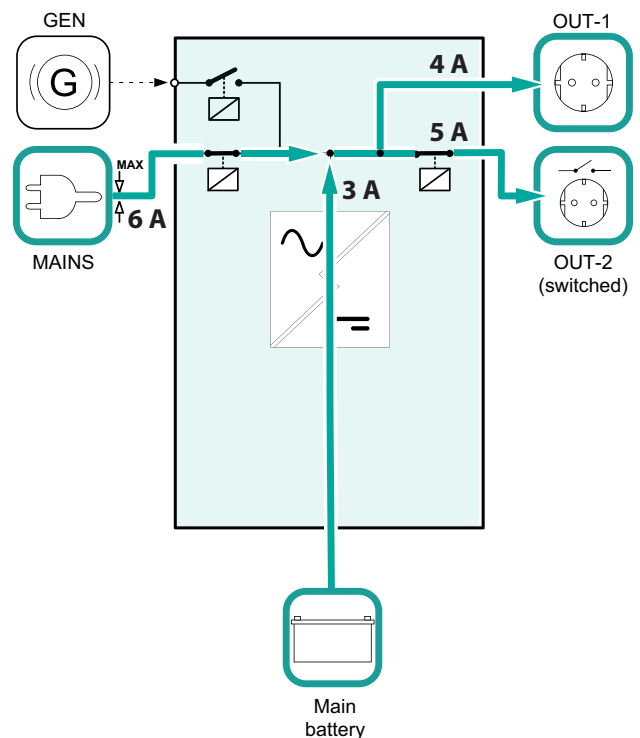
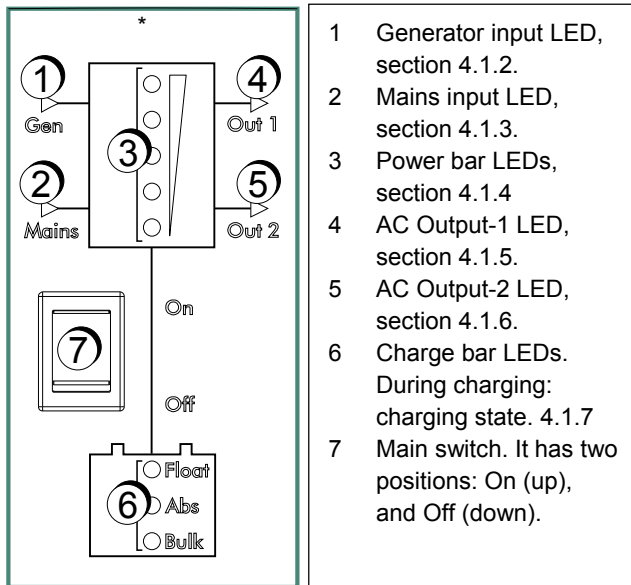

Figure 3-8: Example: The AC-input is limited to 6 A. This is not enough to supply the total load ($4 + 5$ A = 9 A) connected to the AC outputs. The inverter will supply the remaining $9 - 6 = 3$ A.

4 OPERATION



- 1 Generator input LED, section 4.1.2.
- 2 Mains input LED, section 4.1.3.
- 3 Power bar LEDs, section 4.1.4
- 4 AC Output-1 LED, section 4.1.5.
- 5 AC Output-2 LED, section 4.1.6.
- 6 Charge bar LEDs. During charging: charging state. 4.1.7
- 7 Main switch. It has two positions: On (up), and Off (down).

Figure 4-1: Front panel

4.1 LED indicators

See figure 4-1. The operation of the Mass Combi Pro is displayed by means of LED indicators at the front side of the housing. If the Mass Combi Pro is activated and as long as none of the red indicators are illuminated, no failure is detected and the unit is operating normally.

4.1.1 Generator input LED

See figure 4-1 item 1. The arrow is illuminated if AC power comes from the generator.

- On: generator input.
- Off: no generator input.
- Blinking: synchronizing.
- Blinking fast: AC input out of range.

4.1.2 Mains input LED

See figure 4-1 item 2. The arrow is illuminated if AC power comes from the mains.

- On: mains input.
- Off: no mains input.
- Blinking: synchronizing.
- Blinking fast: AC input out of range.

4.1.3 Power bar LEDs

See figure 4-1 item 3. These LEDs have a double function, depending on the mode the Mass Combi Pro is in.

During charging: charge current (20% of nominal charge current per LED).

During inverting: 20% of nominal inverter power per LED).

If the upper LED illuminates red, the inverter is in overload.

4.1.4 AC Output-1 LED

See figure 4-1 item 4. The illuminated arrow indicates that AC Output-1 is powered.

4.1.5 AC Output-2 LED

See figure 4-1 item 5. The illuminated arrow indicates that switched AC Output-2 is powered.

4.1.6 Charge bar LEDs

See figure 4-1 item 6.

- During charging the blinking LED's indicate the charge phase of the three step charge algorithm.
- During inverting the LEDs give a rough estimation of the battery voltage: the more LED's are illuminated, the higher the battery voltage.

4.1.7 Main switch

See figure 4-1 item 7. The only control on the Mass Combi Pro itself is the main switch on the front of the unit. This switch controls on, off and Inverter off (Charger only).

After switching on, expect a three till five second delay before the unit is activated.

With the main switch in position "on", the Combi Pro inverter can also be switched off and on via MasterBus.

If AC power is available on the AC input and within the specified limits, the Mass Combi Pro switches on in Charger Mode and will start to charge the batteries. If the AC power from the external AC-source is unavailable or outside the specified limits, the unit switches on as an inverter.

Move the main switch to the "off" position to switch off the Mass Combi Pro.

If the main switch is set to the Inverter Off-position, the Mass Combi Pro is only able to work as a charger. This means that the inverter mode is disabled. This setting is useful if you want to keep your batteries charged and maintained in case you have left i.e. in the winter time.

4.2 Protections

The Mass Combi Pro is protected against overload, short circuit, overheating and under and over voltage. You can detect failures from the front panel or from the Masterbus control panel.



CAUTION!

The Mass Combi Pro is not protected against reversing polarity of the DC-input, AC voltage on the DC-input and extreme over voltage (>300 VAC) on the AC-input or AC-outputs.

4.2.1 Output overload or short circuit

In case of overload or short circuit during inverter mode, the Power bar top LED illuminates red and the output voltage of the Mass Combi Pro is limited. Mass Combi Pro shuts down if this overload or short circuit lasts over 5 seconds. The Mass Combi Pro will automatically restart after shutdown. After 5 failed start attempts the Mass Combi Pro shuts down permanently, the Power bar top LED and the Charge bar bottom LED stay blinking red. You can restart the Mass Combi Pro only by switching the unit manually off and on with the main switch on the Mass Combi Pro after the overload or short circuit is removed.

4.2.2 Overheating

In the event of overheating the Mass Combi Pro inverter shuts down, the charger reduces charge current. Overheating is most likely caused by:

- heavy or non-resistive loads operating for a longer period;
- high ambient temperature;
- disrupted air flow (dust or too little space).

As soon as the temperature drops below the factory default threshold, the inverter is powered up automatically or the charger resumes its charge current.

4.2.3 Under and over voltage

The AC-input of the Mass Combi Pro is, within limits, protected against over and under voltage. See specifications. If the AC-input voltage is out of operating range, the Mass Combi Pro will switch to inverter mode, disconnecting both AC inputs and it will switch back if the AC-input voltage is within range again. The DC-input of the Mass Combi is also protected against over and under voltage. See specifications. The Mass Combi Pro switches off if the DC-input voltage is out of range.

4.2.4 Dynamic DC input window

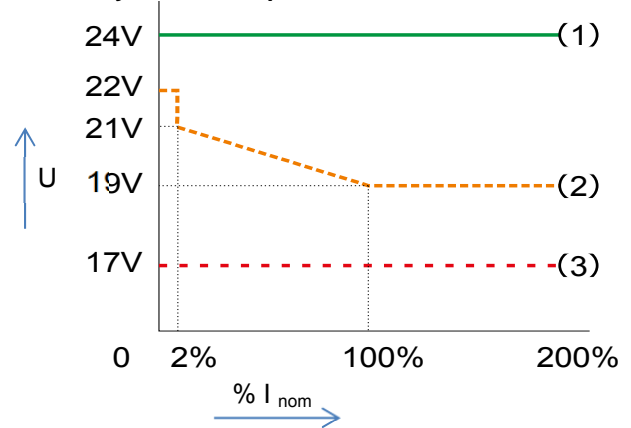

Figure 4-2: Dynamic DC input window

The Dynamic DC input window is used to switch off depending on both the battery voltage and current. The reason for this is that low current loads cause a small voltage drop but they are responsible for severe battery damage.

Shown in figure 4-2 is the graph for a 24 V lead acid battery. The graph shows three lines:

- (1) Low voltage switch on. Above this voltage the inverter switches on.
- (2) Low voltage switch off with delay. Below this line the inverter switches off after a delay.
- (3) Low voltage switch off without delay. Below this line the inverter switches off without delay.

4.3 Operation policies

Via MasterBus configuration, the preferred behaviour of AC in and outputs can be set.

4.3.1 AC input policy

Preference	Description
Mains preferent	Mains input is preferred
Gen preferent	Generator input is preferred
Max fuse preferent	AC source with highest fuse setting
Mains only	No generator
Generator only	No mains

4.3.2 AC Output-2 policy

Preference	Description
Events only	Operation manually
Generator input	Generator input only
Mains input	Mains input only
Gen/mains input	Generator or main input
Always on	Always connected to the loads

By default, AC power is only available on AC output 2 if external power is available on the Main or Gen input.

See section 6.2, AC transfer, to change the operation preferences of AC output 2.

4.4 Maintenance

Checking all connections every 6 months is required. Further, no specific maintenance is required. If necessary, use a soft clean cloth to clean the Mass Combi Pro. Do not use any liquids or corrosive substances, such as solvents, alcohol, petrol or abrasive components.

4.5 Daily use, MasterBus monitoring

Below table shows the MasterBus Monitoring page. On this page you can adjust the daily settings.

Value	Meaning	Default	Range	Group-item	Index
General					
Device state	The state of your Mass Combi Pro		Standby; Inverting; Alarm; Charging; Supporting; Overload; Low battery	1-1	16
Mains fuse	Mains fuse rating	25 A	1..30 A	1-2	19
Inverter	Option to switch Off the inverter to prevent depleting of your batteries.	On	On, Off	1-3	20
Mode	User mode		Initializing; On; Standby; Inverter off; Charger off	1-4	60
AC in state	State of the AC input		No AC present, Generator, Mains, Poor quality	1-5	4
AC out state	State of the AC output		No AC output, AC out1 only, AC out1&2	1-6	5
Main charger	Main charger state		On; Off	1-7	58
Battery (DC)					
Main charger	Main battery state of charger		Bulk; Absorption; Float; Standby; Const. volt; Error	2-1	18
Main battery	Main battery voltage		0..16 V/ 0..32 V/ 0..64 V	2-2	6
Main battery	Main battery current (minus is discharging)		-500..500 A	2-3	7
Battery temp	Main battery temperature		-25..50 °C, if not connected: ---	2-4	21
Shunt device	Selected shunt device for the main battery			2-5	22
Battery SoC	Main battery state of charge		0..100 %	2-6	23
AC inputs					
Mains	Mains voltage		0..300 V	4-1	8
Mains	Mains current		0..50 A	4-2	9
Mains	Mains power		0..10000 W	4-3	94
Generator	Generator voltage		0..300 V	4-4	95
Generator	Generator current		0..50 A	4-5	96
Generator	Generator power		0..20000 W	4-6	97
AC outputs					
AC output 1	AC output 1 voltage		0..300 V	5-1	10
AC output 1	AC output 1 current		0..70 A	5-2	11
AC output 1	AC output 1 power		0..20000 W	5-3	98
AC output 2	AC output 2 voltage		0..300 V	5-5	99
AC output 2	AC output 2 current		0..70 A	5-5	100
AC output 2	AC output 2 power		0..20000 W	5-6	101

5 INSTALLATION

During installation and commissioning of the Mass Combi Pro, the Safety Guidelines & Measures are applicable at all times. See chapter 2 of this manual.

5.1 Unpacking

In addition to the Mass Combi Pro the delivery includes:

- a battery temperature sensor;
- this user's manual;
- MasterBus terminating device.

After unpacking, check the contents for possible damage. Do not use the product if it is damaged. If in doubt, contact your supplier.

Check from the identification label (see section 1.6) whether your Main battery voltage is the same as the DC-input voltage of the Mass Combi Pro (e.g. 24 V main battery set for a 24 V input voltage). Also check that the AC output voltage and output power of the Mass Combi Pro complies with your system and loads.

5.2 Environment

Obey the following stipulations during installation:

- The Mass Combi Pro is designed for indoor use only.
- Ambient temperature: -25 °C to 60 °C, (power derating above 40 °C).
- Maximum usage/installation height: 2000 m.
- Humidity: 0-95 % non-condensing.
- Mount the Mass Combi Pro on a solid surface, with the connecting cables downwards.
- Make sure that the hot air produced during operation can be discharged. The Mass Combi Pro must be mounted in such a way that obstruction of the airflow through the ventilation openings will be prevented.
- No objects must be located within a distance of 10 cm / 4 inch around the Mass Combi Pro. Keep at least 15 cm / 6 inch free space below the Mass Combi Pro.
- Do not locate the Mass Combi Pro in the same compartment as the batteries.
- Do not install the Mass Combi Pro straight above the batteries because of possible corrosive fumes.

5.3 Wiring

The wiring is connected inside the connection compartment. If necessary, the wiring can be fed from the top to the bottom side of the cabinet along the back of the cabinet.

Always use the strain reliefs to fix the wiring. Fix the phase line wire to terminal L, the neutral wire to terminal N and the ground wire to terminal PE, see figure 5-1.

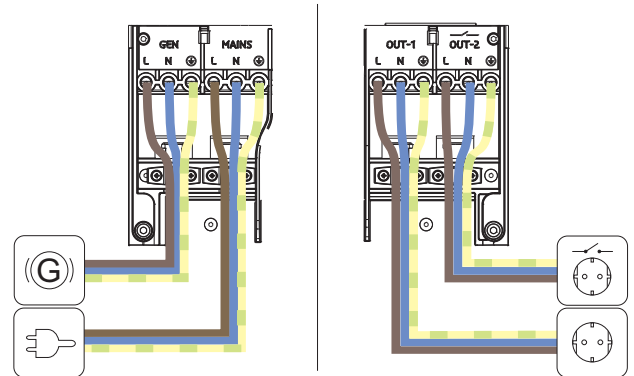

Figure 5-1: AC terminal connections

5.3.1 AC-wiring

For a safe installation the correct wire cross section must be applied. Don't use a cross section that is smaller than indicated. See table below to select the appropriate cross section for the AC wiring:

AC-Current	Minimum cross section:	
0-20 A	2.5 mm ²	AWG 13
20-32 A	4 mm ²	AWG 11
32-48 A	6 mm ²	AWG 9
48-80 A	10 mm ²	AWG 7

Recommended wire colours (refer to local rules and fig 5-1)

Wire color	Meaning	Connected to:
Brown or black	Phase	L1
Blue	Neutral	N
Green/Yellow	Earth	PE / GND

The current entering the Mass Combi Pro must be limited. Therefore the AC-input must be protected by a fuse in the L cable, as specified below. Maximum rating of the generator AC input fuse: 50 A and Mains AC input fuse: 30 A. The PE/GND cable cross section must be at least equal to L1.

5.3.2 DC wiring

Keep in mind that high current will pass through the DC wiring. Keep the cable length as short as possible, this will keep the system efficiency as high as possible. The table shows recommended DC wire sizes:

Model	Minimum cross section:	
12/3000 - 150	95 mm ²	4/0 AWG
24/3500 - 100	50 mm ²	0 AWG
48/3500 - 50	25 mm ²	3 AWG

Use M8 cable lugs terminals on the ends of the wires. These lugs should be crimped with a proper crimping tool. Use the following wire colours for DC wiring (refer to local rules):

Wire colour	Meaning	Must be connected to:
Red	Positive	+ (POS)
Black	Negative	- (NEG)

Position the positive and negative cables next to each other to limit the electromagnetic field around the cables. The negative cable should be connected directly to the negative post of the battery bank or the load side of a current shunt. Do not use the chassis frame or hull of the ship as the negative conductor. The positive battery cable must be fused and connected to the positive post of the battery bank. Fuse rating depends on the applied cable cross section. Tighten the DC connections securely (15 - 20 Nm / 130 - 175 In-Lbs.).

5.3.3 AC safety grounding



WARNING

The ground wire offers protection only if the cabinet of the Mass Combi Pro is connected to the safety ground.

The ground stud (M6) is positioned at the left side of the cabinet, see the overview on page 2, position 12. Connect the earth terminal (PE / GND) to the hull or the chassis with a minimum 10 mm².

In some applications automatic connection between the neutral conductor (N) and earth (PE / GND) is not required or acceptable. Therefore the automatic connection between the neutral conductor (N) and earth (PE / GND) is disabled by default.

For safe installation it is necessary to insert a Residual Current Device (earth leakage switch) of 30 mA in the AC in and outputs of the Mass Combi Pro. Refer to local regulations on these issues!

5.4 Things you need

Make sure you have all the parts you need to install the Mass Combi Pro:

- Mass Combi Pro (included).
- Battery temperature sensor with cable and plug (included).
- AC wiring. Double insulated three wire cable with wire colours according to the locally applicable standards. The applicable length and wire diameter depend on the electrical installation. See section 5.3.1.
- DC-wiring to connect the DC connections of the Mass Combi Pro to the DC-distribution; see section 5.3.2.
- DC-fuse holder with a DC-fuse, to be integrated in the positive DC-cable. For specifications see section 5.3.2.
- Screws / bolts (Ø 6 mm) (with plugs) to mount the cabinet to a surface. Use mounting materials which are suitable to carry the weight of the Mass Combi Pro.
- Batteries. Refer to chapter 8 for specifications.
- Appropriate and reliable cable terminals, cable lugs, battery terminals and cord end terminals.

We recommend as a minimum tool kit:

- Socket wrench 13 mm to fix the DC-input (battery) cables.
- Flat blade screw driver 1.0 x 4.0 mm to fix the screw terminals.
- Tools to fix the screws / bolts (Ø 6 mm) with plugs to mount the cabinets to a surface.
- Philips screw driver to open the connection area of the Mass Combi Pro.

5.5 Removal of the front lid

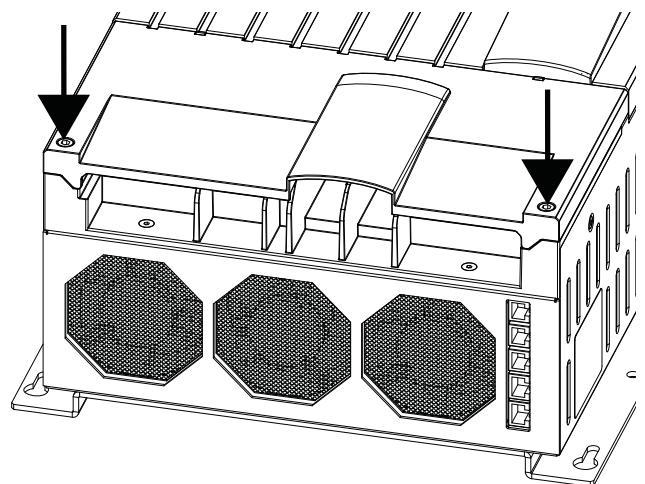

Figure 5-2: Removal of the front lid

Steps:

- 1 Loosen the two screws that secure the front cover plate.
- 2 Lift the front cover plate from the cabinet; see figure 5-3.

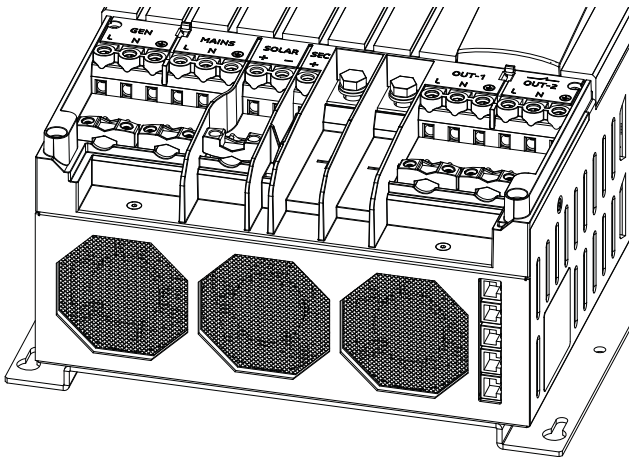

Figure 5-3: Front lid removed

**WARNING**

The front panel must not be removed while the Mass Combi Pro is still connected to a power source!

5.6 Mounting the cabinet to a surface

M6 bolts can be used for the mounting of the cabinet vertically to a surface.

Take the following steps to mount the cabinet:

- 1 Determine for the four mounting spots on the basis of the outline drawings and 150 mm of free space required below the Mass Combi Pro for installation and DIP switch operation.
- 2 Screw the topmost bolts somewhat into the wall.
- 3 Hang the cabinet with its key holes over the two bolts and screw these bolts finger tight, so shifting is still possible.
- 4 Place the two lowermost bolts.
- 5 Fasten all bolts securely.

5.7 Wiring instructions**WARNING**

Have installation work done by a licensed electrician only. Before connecting the wiring, make the AC distribution as well as the DC distribution voltage free. Move the main switch to the "Off"-position.

**CAUTION!**

Short circuiting or reversing polarity may lead to serious damage to the batteries, the Mass Combi Pro, the solar panels, the wiring and/or the terminal connections. Fuses between the batteries and the Mass Combi Pro cannot prevent damage caused by reversed polarity. The damage as a result of reverse polarity is not covered by the warranty.

**CAUTION!**

Too-thin cables and/or loose connections can cause dangerous overheating of the cables and/or terminals. Therefore tighten all connections well. Only use cables of the correct size.

5.8 Installation overview

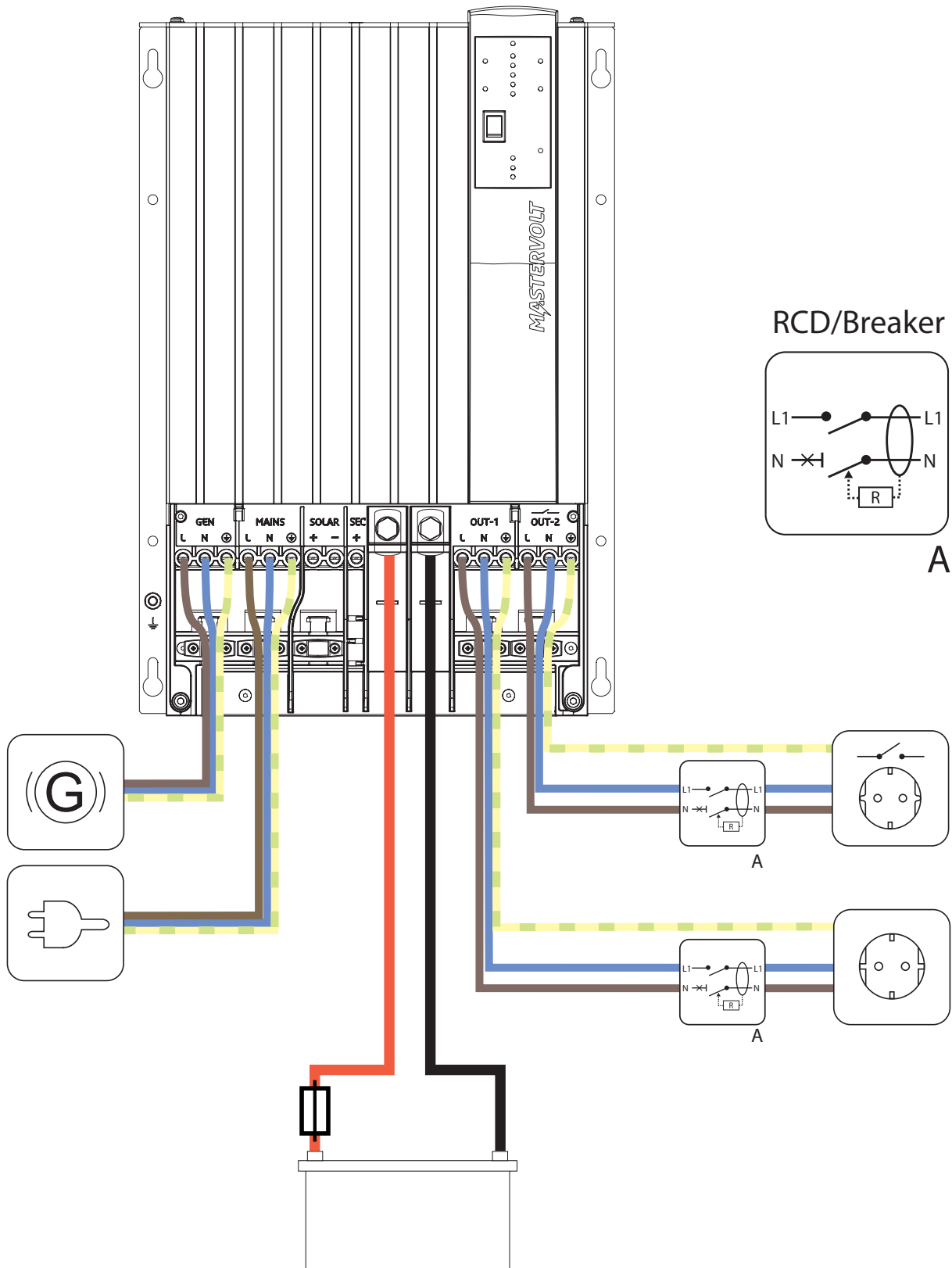

Figure 5-4: Installation overview for one Mass Combi (stand-alone operation)



CAUTION!

Ensure correct polarities, cross sections and fuses for all wiring. An RCD according to local regulations must be connected to output-1 and 2.

5.9 Setting up a MasterBus network

M All devices that are suitable for MasterBus are marked by the MasterBus symbol.

MasterBus is a fully decentralized data network for communication between the different Mastervolt system devices. It is CAN-bus based which has proven itself as a reliable bus-system in automotive applications. MasterBus is used as power management system for all connected devices, such as the inverter, battery charger, generator and many more. This enables communication between the connected devices, for instance to start the generator when the batteries are low. MasterBus reduces complexity of electrical systems by using UTP patch cables. All system components are simply chained together. Therefore each device is equipped with two MasterBus data ports. As only a few MasterBus cables are needed, installation and material costs are reduced importantly.

New devices can be added to the existing network easily. Consequently the MasterBus network is highly flexible for extended system configuration. Mastervolt also offers several interfaces like the Modbus interface, making even non-MasterBus devices suitable to operate in the MasterBus network. For central monitoring and control of the connected devices Mastervolt offers different panels, like the full colour MasterView System panel. All monitoring panels can be used for monitoring, control and configuration of all connected MasterBus equipment.

CAUTION! Never connect a non-MasterBus device to the MasterBus network directly! This will void warranty of all MasterBus devices connected.

5.10 How to set up a MasterBus network

Every MasterBus device is equipped with two data ports. When two or more devices are connected via these ports, a local data network called the MasterBus is formed. Keep the following rules in mind:

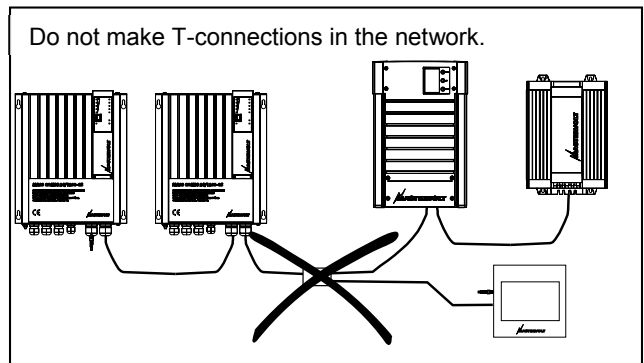
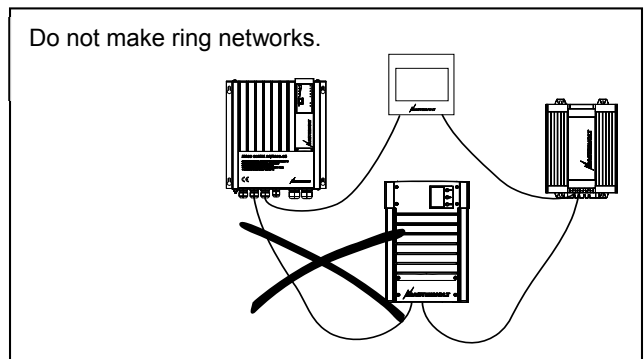
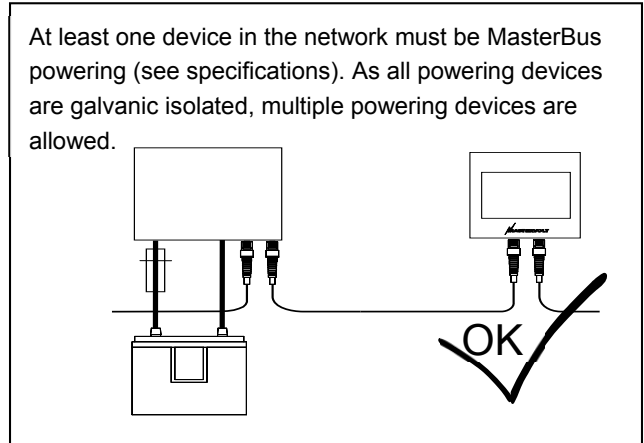
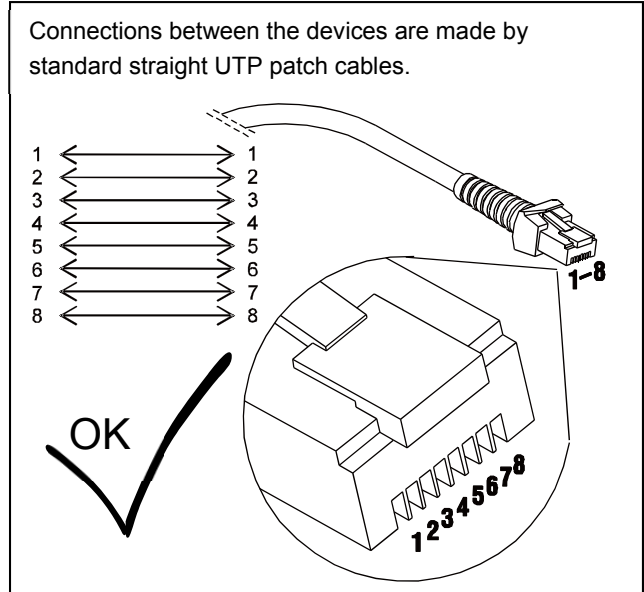
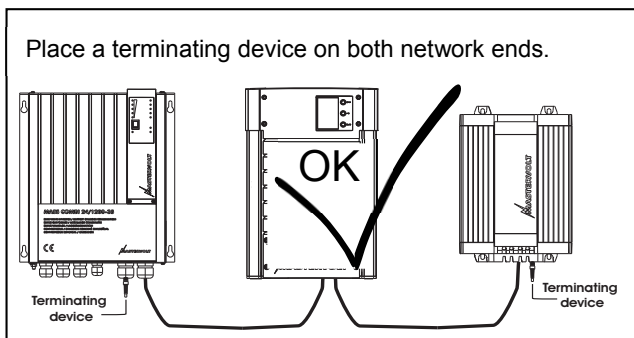

6 CONFIGURATION

The Mass Combi Pro is provided with two groups of DIP-switches to adjust the Mass Combi Pro according to the specifications of the electrical installation, see figure 6-1. DIP-switch settings are 0 for default values. The Mass Combi Pro also features the more sophisticated MasterBus configuration.

Previously done MasterBus settings are overruled by the DIP-switch settings and they are greyed out in the menu. When a DIP-switch is set to 0, the corresponding MasterBus setting becomes default too, regardless the previous setting.

6.1 Configuration via DIP-switches

The DIP-switches are located in the connection compartment. Figure 6-1 shows the location of the DIP-switches and the print on the inside of the front cover plate.

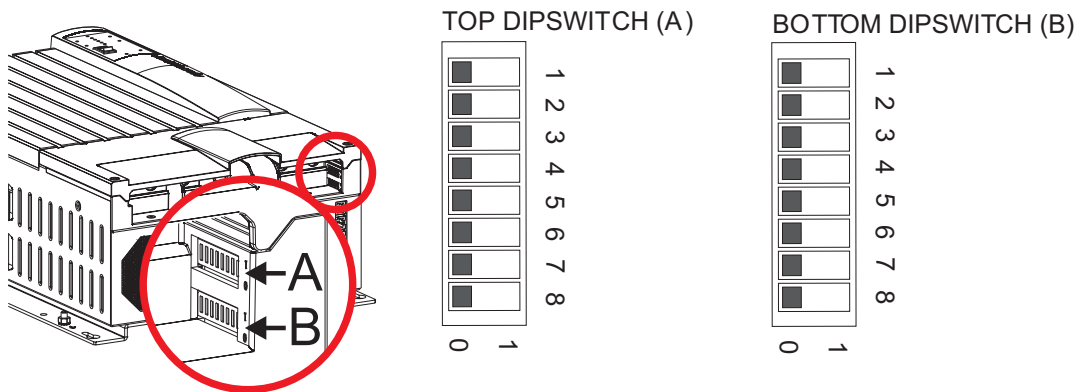

Figure 6-1: DIP-switches and cover print

6.1.1 Ground relay

For safe installation:

- Residual Current Devices (RCD) must be integrated in the AC inputs and AC outputs of the Mass Combi Pro.
- The neutral conductor (N) of the AC output of the Inverter must be connected to the safety ground (PE/GND) when the Mass Combi Pro is working as an inverter.

The ground relay function allows you to connect the Neutral conductor (N) of the inverter output circuit to the Safety Ground (PE / GND) automatically when the Mass Combi is working as an inverter. Refer to local standards on this issue.

DIP switch	Function					
A1-A2	Parallel mode	0-0: Stand alone	1-0: Master 0	0-1: Slave	1-1: NA	
A3	Output frequency inverter	0: 50 Hz		1: 60 Hz		
A4	Energy saving mode	0: off		1: on (scan mode)		
A5-A6	Secondary charger	12/3000	0-0: Follow main battery	1-0: 12 V constant voltage	0-1: 12 V 3Step	1-1: 12 V constant voltage
		24/3500	0-0: Follow main battery	1-0: 24 V constant voltage	0-1: 12 V 3Step	1-1: 12 V constant voltage
		48/3500	0-0: 24 V 3Step	1-0: 24 V constant voltage	0-1: 12 V 3Step	1-1: 12 V constant voltage
A7-A8	Main battery type	0-0: Flooded	1-0: Gel	0-1: AGM	1-1: Flooded traction	
B1-B2	Fuse setting mains input	0-0: 30 A	1-0: 16 A	0-1: 10 A	1-1: 6 A	
B3	Fuse setting generator input	0: 25 A		1: 50 A		
B4	Power sharing mode	0: enabled		1: disabled		
B5	Generator / Mains support mode	0: disabled		1: enabled		
B6	AC voltage input window	0: wide (+/-40 V)		1: narrow (+/-23 V)		
B7	Generator AC frequency window	0: wide (+8/-10 Hz)		1: narrow (+/-5 Hz)		
B8	Ground relay	0: disabled		1: enabled		

6.2 MasterBus configuration

Parameters below can be changed via the MasterBus network. DIP switch settings overrule MasterBus settings. If DIP switches are not set to default, the corresponding MasterBus configuration is greyed out

Value	Meaning	Default	Adjustable range
Device			
Language	Language that is displayed on a monitoring device connected to the MasterBus	English	English, Nederlands, Deutsch, Français, Castellano, Italiano, Norsk, Svenska, Suomi, Dansk
Device name	Name of this particular device in MasterBus. This name will be recognized by all devices that are connected to the MasterBus network.	MCU [Serial number]	All names with a maximum of 12 characters.
Lock config	Option to lock the configuration (installer login).	Not checked	Not checked, Checked
Factory settings	Option to reset the configuration to default (installer login).	Not selected	Not checked, Selected
System			
MasterBus power	Checkbox to have the Combi power MasterBus or not.	Checked	Checked, Not checked
Silent mode	Activate this mode to reduce the sound of the cooling fans. This may affect the charging time.	Not checked	Not checked, Checked
Silent mode	Maximum fan speed	36 %	25-100 %
Shunt device select	Select a device in the list, the values of which must be used by the Mass Combi Pro.	No shunt	Shunt devices in the list
Main charger			
Maximum current	Maximum charging current adjustable.	100 A	1..150 A / 1..100 A / 1..50 A
Method	Charging method selectable.	3-Step +, refer to chapter 3	3-Step+, constant voltage
Battery type	Select the main battery type.	Flooded (Lead acid wet cell)	User defined, Flooded, Gel, AGM, Spiral, MLI, Flooded traction, Nickel Cadmium
Bulk			
Bulk voltage	Maximum Bulk voltage (adjustable if User Defined).	14.40/28.80/57.60 V	8..16.00/16..32.00/32..64.00 V
Min bulk time	Minimum time that the charger stays in Bulk mode.	2 min	0-600 min
Start bulk time	Voltage at which to start the bulk timer.	13.25/26.50/53.00	
Max bulk time	Maximum time the bulk phase lasts before the charger changes to absorption.	480 min	0-600 min, Max bulk time > Min bulk time
Bulk ret. volt.	Bulk return voltage. If the battery voltage has dropped below this voltage, the charger will return to bulk phase.	12.8/25.6/51.2V	
Bulk return time	Delay time before the charger returns to Bulk after reaching the Return to Bulk voltage.	30 sec	0-255 sec
Absorption			
Abs. voltage	Absorption voltage (adjustable if User Defined is selected).	14.25/28.50/57.0 V	8-16.00/16-32.00/32-64.00 V
Max absorp.time	Maximum time that the charger stays in absorption mode.	240 min	1-65535 min
Return amps	Charging current at which the charger changes to Float phase.	9.0 A / 6.0 A / 3.0 A	0.0-25.0
Min absorp.time	Minimum time that the charger stays in absorption mode.	15 min	0-255 min

Value	Meaning	Default	Adjustable range
Float settings			
Float voltage	Float voltage (adjustable if User Defined).	13.25/26.50/53.0 V	8-16.00/16-32.00/32-64.00 V
Inverter			
Voltage	AC voltage	230 V	180-260 V
Frequency	AC frequency	50 Hz	50 Hz, 60 Hz
Enable GND rel.	Option to enable ground relay	Not checked	Not checked, checked
Energy save mode	Option to enable Energy save mode	Not checked	Not checked, checked
Scanning below	The Combi starts scanning below this inverted power level in Energy save mode.	10 W	10-250 W
Dynamic window	Select to base the input window upon battery type default values or upon your own preset values. Refer to section 4.2.4	Use battery type	Use battery type, user defined (Use battery type: dynamic input window still present, but not configurable)
DC high off	High battery voltage for inverter switch off (12/24/48V, user defined only).	16.00/32.00/64.00V	13.00-16.00/26.00-32.00/52.00-64.00V
DC high on	High battery voltage for inverter switch to DC High Off alarm (12/24/48V, user def.)	15.50/31.00/62.00V	13.00-16.00/26.00-32.00/52.00-64.00V
DC low off I=0%	Low battery voltage at which the inverter switches off when the battery current is 0-2% of nominal (12/24/48V, user def.)	10.00/20.00/40.00V	9.50-13.00/19.00-26.00/38.00-52.00V
DC low off I=2%	Low battery voltage at which the inverter switches off when the battery current is 2% of nominal (12/24/48V, user def.)	9.75/19.50/39.00V	9.50-13.00/19.00-26.00/38.00-52.00V
DC low off 100%	Low battery inverter switch off voltage, batt. current 100% (12/24/48V, user def.)	9.50/19.00/38.00V	9.50-13.00/19.00-26.00/38.00-52.00V
DC low on	Low battery inverter switch on voltage at DC Low off alarm (12/24/48V, user def.)	12.00/24.00/48.00V	10.00-13.00/20.00-26.00/40.00-52.00V
DC low off delay	Delay time before inverter switches off on low battery voltage.	30 s	0-30 s
AC transfer			
AC input policy	Define which AC input to be used under which conditions, refer to section 4.3	Gen preferent	Mains preferent, Gen preferent, Max fuse prefer
AC out 2 policy	Define under which conditions to use AC output-2, refer to section 4.3	Gen/Mains input	Events only, Generator input, Mains input, Gen/Mains input, Always on
Generator fuse	Generator fuse value	25 A	1-50 A
Mains fuse max.	Mains fuse maximum value that can be set in the monitoring tab	30 A	1-30 A
Mains limit A	Mains fuse value setting	6 A	1-30 A
Mains limit B	Mains fuse value 10A	10 A	1-30 A
Mains limit C	Mains fuse value 16A	16 A	1-30 A
Power sharing	Power sharing mode option, chapter 3.	Checked	Not checked, checked
Allow AC support	AC support mode option, chapter 3.	Not checked	Not checked, checked
Gen. high volt.	Generator AC input window	275 V	184-275 V
Gen. low volt.	Generator AC input window	180 V	184-275 V
Gen. high freq.	Generator AC input window	58 Hz	36-68 Hz
Gen. low freq.	Generator AC input window	40 Hz	36-67 Hz
Generator delay	Time to trigger a Generator alarm	10 s	5 – 300 s
Mains high volt.	Mains AC input window	275 V	184-275 V
Mains low volt.	Mains AC input window	180 V	184-275 V
Mains high freq.	Mains AC input window	65 Hz	35-68 Hz
Mains low freq.	Mains AC input window	40 Hz	35-68 Hz
Mains delay	Time to trigger a Mains alarm	10 s	5-20 s

6.2.1 MasterBus alarms

This is the Mass Combi Pro list of MasterBus alarms with their meaning

Alarm	Description
Overload	Combi in overload. The loads exceed the nominal inverter power.
Over temperature	Internal temperature of the Combi is too high.
Battery low	Main battery voltage is too low.
Battery high	Main battery voltage is too high.
Batt temperature	Battery temperature is out of range.
Temp sense error	An error has been detected in the temperature sensor signal.
Sync. error	Two or more Mass Combi Pro's in a multiple configuration do not synchronize well.
Config error	Configuration error, most often in multi Combi installations. Check MasterBus and DIP switch settings.
Install error	Installation error around the Mass Combi Pro, not inside the unit. Check all connections.
System error	Internal Mass Combi Pro error. Contact your Mastervolt supplier.
Cable losses	Cable between Mass Combi Ultra and battery is too thin causing too high voltage drops
Shunt Mismatch	Setting for nominal voltage (12, 24 or 48 V) at the Mastershunt or the nominal voltage of the MLI batteries differs from nominal voltage detected by the Mass Combi Pro. Check battery voltage and settings of the Mastershunt or voltage of the MLI Pro battery.

6.2.2 List of event sources

This is the Mass Combi Pro list of event sources. These can initiate an event at another MasterBus connected device.

Event source	Description
Disabled	(no event programmed)
Inverting	The Mass Combi Pro is in Inverter mode
Charging	The Mass Combi Pro is in Charge mode
Supporting	The Mass Combi Pro is in Supporting mode
Overload	The inverter current is too large
Low bat	The main battery voltage has dropped below the Low bat value
Alarm	A Mass Combi Pro alarm has been triggered
Generator input	Generator input ("GEN") is present
Mains input	Mains input ("MAINS") is present
ACout 2 enabled	Switched Output-2 is enabled
Bulk	Charge phase Bulk
Absorption	Charge phase Absorption
Float	Charge phase Float
External fan	Trigger point to activate an external cooling fan
Silent mode	The Mass Combi Pro is in Silence mode

6.2.3 List of event commands

This is the Mass Combi Pro event commands list. Other MasterBus connected devices can be configured to initiate these commands

Event command	Description
Inverter On/Off	Change the Mass Combi Pro inverter state to On/Off
Charger On/Off	Change the Mass Combi Pro charger state to On/ Off
Bulk	Changes to charge phase Bulk
Absorption	Changes to charge phase Absorption
Float	Changes to charge phase Float
Mains limit A	Fuse setting of the Mains input is set to 6 A (adjustable)
Mains limit B	Fuse setting of the Mains input is set to 10 A (adjustable)
Mains limit C	Fuse setting of the Mains input is set to 16 A (adjustable)
AC out 2 enabled	Switched Output-2 is enabled
Power off	Command to switch off the charger, inverter and open the input relais
Silent mode	Command to switch on/off the silent mode

7 COMMISSIONING, DECOMMISSIONING

7.1 Commissioning



CAUTION!

Check the polarity of all wiring before commissioning: plus connected to plus (red cables), minus connected to minus (black cables).

The DIP-switches must be adjusted prior to commissioning; see chapter 6.

Follow the steps described below to switch on the Mass Combi Pro.

- 1 Tighten all strain reliefs.
- 2 Check all wiring and connections.
- 3 Close the front cover plate of the connection compartment.
- 4 Place the DC-fuse(s) of the DC-distribution to connect the batteries to the Mass Combi Pro.



WARNING

When placing this fuse, a spark can occur, caused by the capacitors used in the Mass Combi Pro. This is particularly dangerous in places with insufficient ventilation, due to the gassing of the batteries an explosion can occur and avoid having flammable materials close by.

Now the Mass Combi Pro is ready for operation.

7.2 Decommissioning

If it is necessary to put the Mass Combi Pro out of operation, follow the instructions in order of succession as described below:

- 1 Move the Main-switch of the Mass Combi Pro to "Off".
- 2 Remove DC-distribution fuses and/or disconnect the batteries.
- 3 Remove AC-input fuses and/or switch off the AC-sources.
- 4 Open the connection compartment of the Mass Combi Pro.
- 5 Check with a suitable voltage meter whether the inputs and the outputs of the Mass Combi Pro are voltage free.
- 6 Disconnect all the wiring.

Now the Mass Combi Pro can be demounted in a safe way.

7.3 Trouble shooting

If a failure occurs, the origin of the failure is displayed by means of the LEDs at the front of the Mass Combi, see figure 7-1.

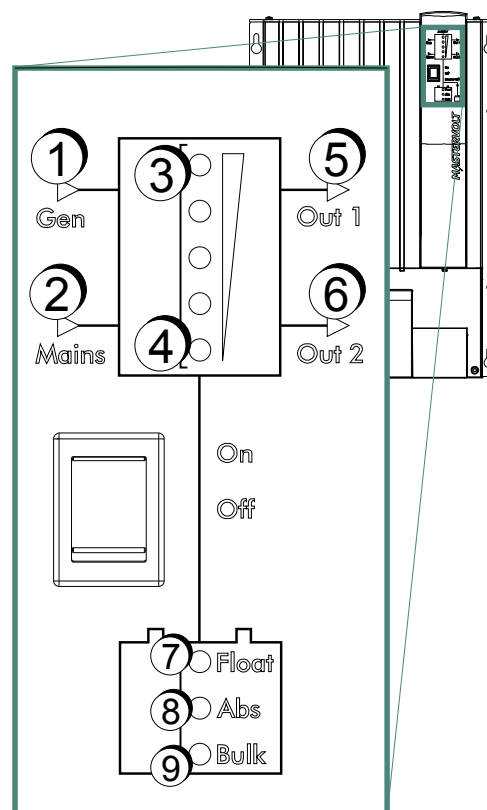

Figure 7-1: Error LEDs

The table shows the meaning of the error indications and their solutions, together with other directions. If you cannot solve a problem using this table, contact your local Mastervolt Service Centre. See www.mastervolt.com. Make sure you have the following information present if you have to contact your local Mastervolt Service Center to solve a problem:

- Article and serial number (see section 1.7).
- Software version (by means of MasterAdjust software).

7.3.1 Trouble shooting table

illuminating LEDs	MasterBus alarm	Explanation / Possible cause	What to do
Normal operation and warnings			
None		The Mass Combi Pro is switched off manually.	Switch on the Mass Combi Pro by means of the main switch.
(1) blinking slowly (1x/sec)		Inverter is synchronizing voltage and frequency to generator AC.	Wait until the inverter is ready synchronizing. After this, it will activate the generator input.
(1) blinking fast (4x/sec)	MB monitoring: ACin Low quality	Error: generator input voltage or frequency out of range	Check generator voltage and frequency, refer to generator input specifications in chapter 8.
(2) blinking slowly (1x/sec)		The inverter is synchronizing its voltage and frequency to mains AC	Wait until the inverter is ready synchronizing. After this, it will activate the mains input.
(2) blinking fast (5x/sec)	MB monitoring: ACin Low quality	Error: mains input voltage or frequency out of range	Check mains voltage and frequency, refer to generator input specifications in chapter 8.
(3) red	MB monitoring: Overload	Inverter in overload, inverted power exceeds 3500 W	Check the load connected and disconnect
(9) red	Battery low	Battery voltage low	Stop inverting, start charging
(9) blinking red		Charging a low battery	
Errors (Mass Combi Pro shuts down)			
(3) and (9) red, (4) yellow	Overtemperature	Combi too hot. Restart when alarm is over	Check ventilation
(9) red, 7 and 8 yellow	Battery high	Battery voltage too high, Combi restarts when the alarm is over.	Check battery voltage setting
(9) red, (7) yellow, (8) off	Temp sense error	Temperature sensor sends a wrong signal.	Check battery sensor and its cable
(9) red, (7) yellow, (8) off	Batt temperature	Battery hot, Combi restart when alarm is over.	
(3) and (9) red	System error, Sync error, Config error	Communication disturbed Configuration wrong	Check sync cables and connectors
Permanent errors (manual reset required)			
(3) and (9) blinking fast red	Overload	Number of inverter overload restart attempts exceeded.	Reduce the output loads, shut off and on the Mass Combi Pro.
	System error	Hardware issue	Switch off and on the Mass Combi Pro.
(5) and (6) blinking fast	Install error	Installation error	Correct installation, shut off and on the Mass Combi Pro.

8 TECHNICAL DATA

8.1 Specifications

Mass Combi Pro	12/3000-150	24/3500-100
Article number	38013000	38023500
<i>Inverter specifications</i>		
Nominal battery voltage	12 V	24 V
Inverter output voltage	230 V ($\pm 2\%$) (adjustable 180 – 200 V)	
Frequency	50/60 Hz ($\pm 0.005\%$) configurable	
Continuous power @Tamb=25°C, cos phi = 1	3000 W	3500 W
Continuous power@Tamb=40°C, cos phi = 1	3000 W	3500 W
Max. peak load	6000 W	7000 W
Output waveform	True sine wave, Thd < 1 % under standard conditions	
Max. efficiency	$\geq 90\%$	$\geq 92\%$
DC input voltage range	9.5 – 16 V	19 – 32 V
Dynamic input window battery	Programmable, current dependent switch-off levels, vary with set battery type (Gel / AGM settings below)	
Switch off voltage low battery@ load $\leq 2\%$	11.0 V ($\pm 2\%$)	22.0 V ($\pm 2\%$)
Switch off voltage low battery@ load 2-100%	10.5 V - 9.5 V ($\pm 2\%$)	21.0 V - 19.0 V ($\pm 2\%$)
Switch on voltage low battery	12.0 V ($\pm 2\%$)	24.0 V ($\pm 2\%$)
Switch off voltage high battery	16.0 V ($\pm 2\%$)	32.0 V ($\pm 2\%$)
Switch on voltage high battery	14.5 V ($\pm 2\%$)	29.0 V ($\pm 2\%$)
Max. ripple on DC @ full load	< 5% RMS	< 5% RMS
Nominal DC current at full load	300 A	175 A
Recommended batteries	300 – 900 Ah*	200 – 600 Ah*
<i>No load, DC drain</i>		
Off mode (hard switched)	0 W	0 W
Inverter off mode (remote)	4 W	4 W
Energy saving mode	7 W	7 W
Normal operation mode	16 W	16 W
<i>Battery charger specifications</i>		
Input voltage range	184 – 275 V	184 – 275 V
Max AC input current	12 A	16 A
Max. charge current @Tamb=40°C	150 A @ 14.25 V adjustable	100 A @ 28.5 V adjustable
Charge characteristic	Mastervolt 3-step+	
Battery types	AGM / Gel / MLi / Flooded / Flooded traction / Spiral / NiCad	
Battery temperature sense	Input present, sensor included	
Voltage sense	Only through MasterShunt, else automatic compensation	
<i>Transfer system specifications</i>		
AC input 1 ("GEN") (switched)	Yes, 50 A	Yes, 50 A
AC input 2 ("MAINS") (switched)	Yes, 30 A	Yes, 30 A
AC Output 1 ("OUT-1")	Yes, 67 A	Yes, 67 A
AC Output 2 ("OUT-2") (switched)	Yes, 50 A	Yes, 50 A
AC input fuses	No	No
Transfer speed	Seamless (<1 ms)	Seamless (<1 ms)
Transfer voltage range (adjustable)	184 V-275 V	184 V-275 V
Transfer frequency range (adjust.)	35 – 68 Hz	35 – 68 Hz
Power sharing	Yes	Yes
Generator/Mains support	Yes	Yes
Auto-synchronize with AC input 1 / 2	Yes	Yes

Mass Combi Pro	12/3000-150	24/3500-100
Parallelling/3-phase		
Parallel stacking	Yes, up to 10 standard from hardware version D	
3-phase configuration	Yes, up to 3 x 3 from hardware version D	
General specifications		
Dimensions (HxWxD)	472x318x178 mm	472x318x178 mm
Weight	15.3 kg	15.3 kg
Protection degree	IP23 (vertical wall mounting)	
Safety class	IEC protection class I	
Grounding	Ground relay standard, includes ground stud (ABYC compliant) configurable	
Operating temperature	-25 °C to 60 °C, above 40 °C derating	
Overvoltage category	Gen: OVII; Mains: OVIII	
Pollution degree	PDII	
Relative humidity	Protected against humidity and condensing air by conformal coating, max 95% relative humidity, none condensing	
Standards, approvals & listings	CE, ABYC	
Options & features		
Front panel display	Yes, shows charge state, inverter power, input/output state and includes on/off/inverter off switch	
Battery temperature sensor	Yes	
Cooling	Maintenance free vario fans	
MasterBus functionality		
MasterBus powering	Standard on, selectable	
Overload protection		
<i>Gen & Mains input</i>		
Digital fuse	Adjustable with three preset values	
Frequency monitoring	Relay disconnects when frequency is out of range	
Voltage monitoring	Relay disconnects when voltage is out of range	
Overvoltage protection	Non recoverable protection of the unit	
<i>Output-1 & 2</i>		
Short circuit protection	Yes (inverter only)	
Overload protection	Yes	
Over temperature protection	Yes	
AC backfeed protection	Yes	
<i>Main & Secondary battery</i>		
Short circuit protection	Yes	
Reversed polarity protection	No	
High / low battery voltage	Yes	

8.2 Correct disposal of this product

(Waste Electrical & Electronic Equipment)



This product is designed and manufactured with high quality materials and components, which can be recycled and reused. When this crossed-out wheeled bin symbol is attached to a product, it means the product is covered by the European Directive 2012/19/EU.

Please be informed about the local separate collection system for electrical and electronic products.

Please act according to your local rules and do not dispose of your old products with your normal household waste. The correct disposal of your old product will help prevent potential negative consequences to the environment and human health.

8.3 Dimensions

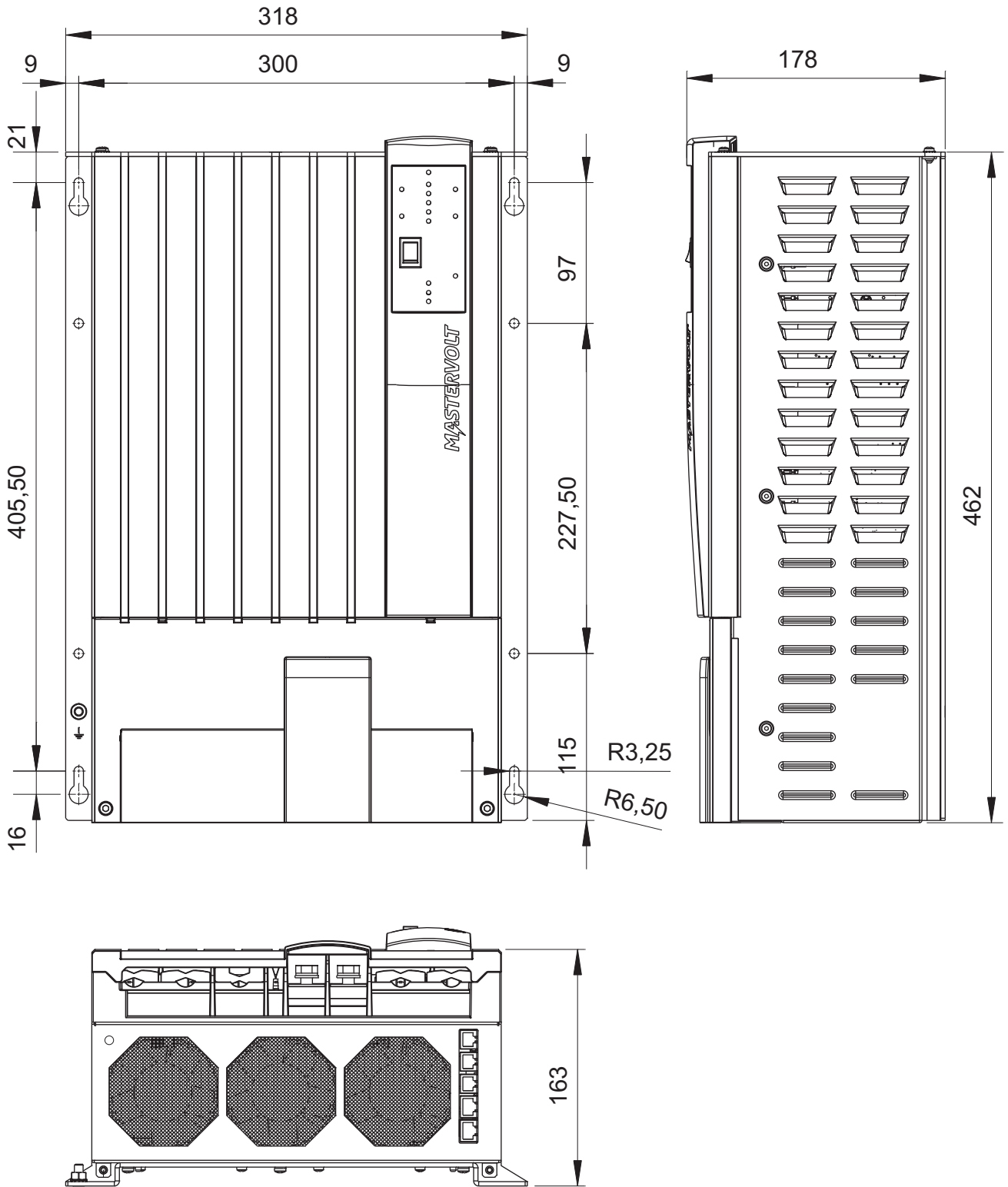

Figure 8-1: Dimensions in mm

9 ORDERING INFORMATION

Part number	Description
77049100	ANL Fuse 100 A
77049200	ANL Fuse 200 A
77049400	ANL Fuse 400 A
607006	ANL Fuse base
701	Battery switch 275 A
6502000010	Sync cable for parallel and three phase operation, 1 m / 3 ft
6502000030	Sync cable for parallel and three phase operation, 3 m / 9 ft
6502001030	Sync cable for parallel and three phase operation, 6 m / 19 ft
6502100100	Sync cable for parallel and three phase operation, 10 m / 33 ft
6502100150	Sync cable for parallel and three phase operation, 15 m / 49 ft
41500500**	Battery temperature sensor, incl. 6 m / 19 ft cable
41500800	Battery temperature sensor, incl. 15 m / 49 ft cable
77040000**	MasterBus terminating device
77040020	MasterBus connection cable (UTP patch cable), 0,2 m / 0.6 ft
77040050	MasterBus connection cable (UTP patch cable), 0,5 m / 1.6 ft
77040100	MasterBus connection cable (UTP patch cable), 1,0 m / 3.3 ft
77040300	MasterBus connection cable (UTP patch cable), 3,0 m / 10 ft
77040600	MasterBus connection cable (UTP patch cable), 6,0 m / 20 ft
77041000	MasterBus connection cable (UTP patch cable), 10 m / 33 ft
77041500	MasterBus connection cable (UTP patch cable), 15 m / 49 ft
77042500	MasterBus connection cable (UTP patch cable), 25 m / 82 ft
77045000	100 m / 330 ft MasterBus cable (UTP cable)
77040010	MasterBus RJ45 conn 8-pole 25 pcs
77040015	Cover for RJ45 conn. -set a 25 st
77050000	Complete set to assemble UTP patch cables: 100 m / 330 ft UTP cable, 50 pcs. modular jacks and crimping tool
77030100	MasterBus – USB interface, required when using MasterAdjust or MasterView System software.
77010305	MasterView Easy, Touch screen to control and monitor all MasterBus products
77010400	MasterView System, Full-colour touch screen to control and monitor all MasterBus products
77020100	MasterShunt 500, DC-distribution module for exact readout of battery voltage, charge / discharge current, and state of charge. Continuous rating: 250 A, peak current: 500 A
77020200	DC-Distribution 500. The Mastervolt DC Distribution offers fused DC connections to install up to four different devices
77030500	Multipurpose Contact Output, MasterBus controlled potential-free contact
77031500	Digital AC 1x6 A, MasterBus interface for switching AC loads up to 6 A

** Standard included with the delivery of the Mass Combi Pro

Mastervolt can offer a wide range of products for your electrical installation, including automatic AC transfer switches, remote control panels and DC distribution kits. See our website www.mastervolt.com for an extensive overview of all our products



