

PARTS LIST 01/2001

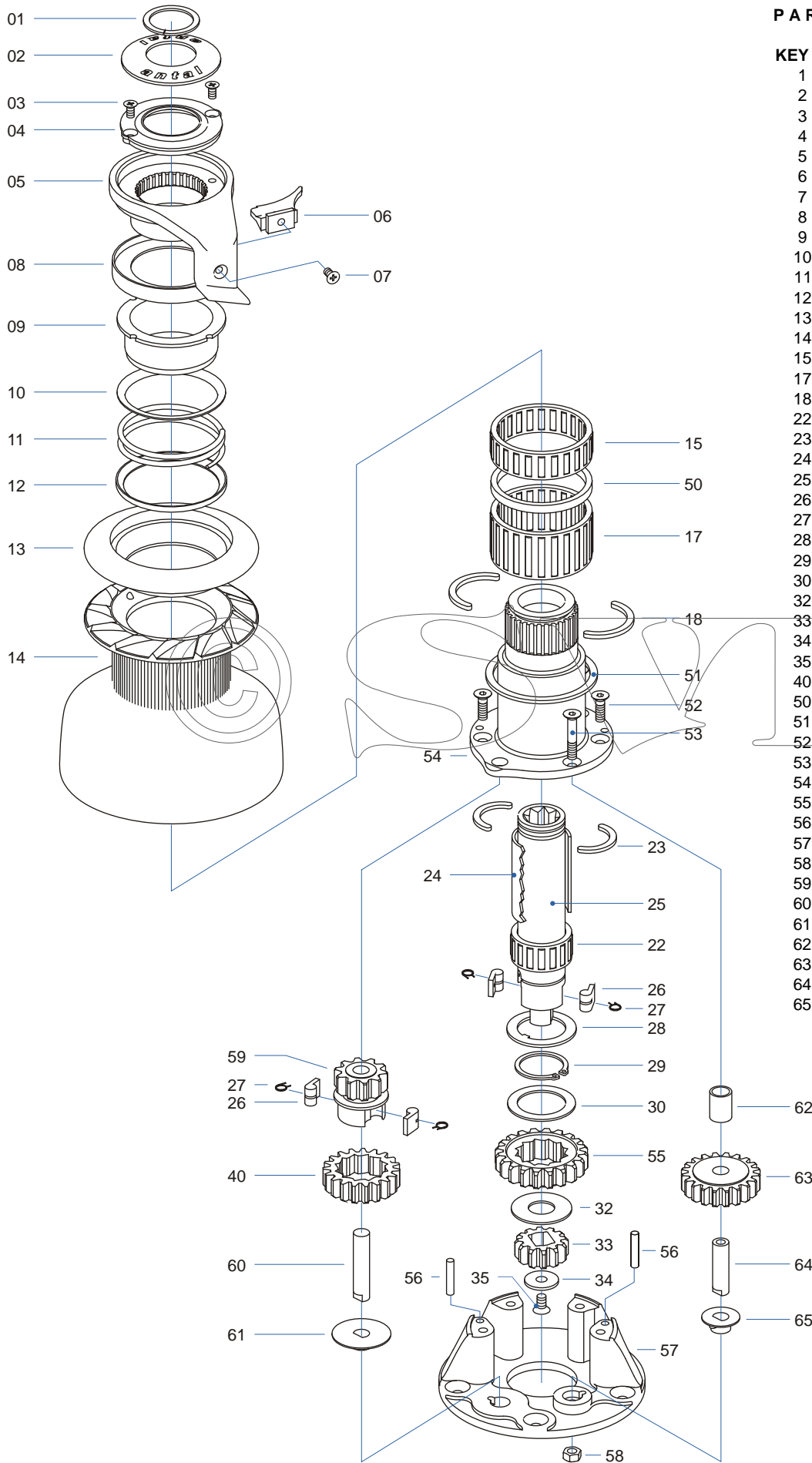

KEY N.	DESCRIPTION	QUANT.
1	CIRCLIP	1
2	S.STEEL CAP	1
3	SCREW	2
4	PLASTIC CAP	1
5	ST ARM	1
6	STRIPPER	1
7	SCREW	1
8	PLASTIC ST RING	1
9	SPRING PIPE	1
10	UPPER SPRING RING	1
11	ST SPRING	1
12	LOWER SPRING RING	1
13	UPPER ST DISK	1
14	DRUM	1
15	BASE ROLLER BEARING	1
17	BASE ROLLER BEARING	1
18	BRONZE HALF RING	2
22	SHAFT ROLLER BEARING	1
23	HALF BRONZE RING	2
24	PLASTIC SPACER	1
25	S.STEEL SHAFT	1
26	PAWL	4
27	PAWL SPRING	4
28	S.STEEL WASHER	1
29	SEGER	1
30	PLASTIC WASHER	1
32	S.STEEL WASHER	1
33	BRONZE GEAR "A1"	1
34	S.STEEL CAP	1
35	SCREW	1
40	BRONZE GEAR "B1"	1
50	PLASTIC SPACER	1
51	PLASTIC WASHER	1
52	SCREW	4
53	SCREW	1
54	CHROMED BRONZE BASE	1
55	BRONZE GEAR "A2"	1
56	S.STEEL PIN	2
57	ALU LOWER BASE	1
58	NUT	1
59	BRONZE GEAR "B2"	1
60	S.STEEL SPINDLE	1
61	PLASTIC WASHER	1
62	S.STEEL SPACER	1
63	BRONZE GEAR "D1"	1
64	S.STEEL SPINDLE	1
65	PLASTIC WASHER	1

PARTS LIST 01/98

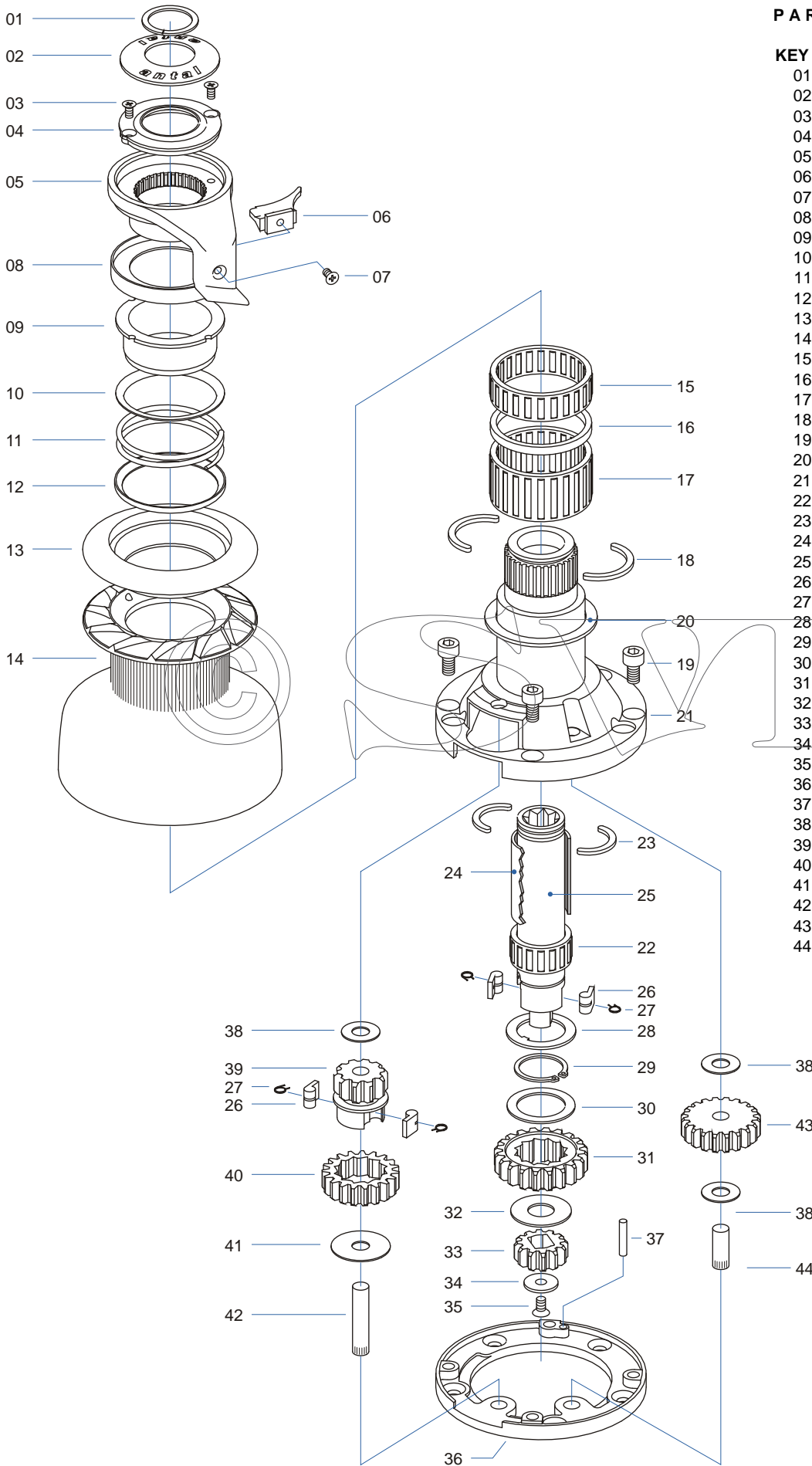

KEY N.	DESCRIPTION	QUANT.
01	CIRCLIP	1
02	S.STEEL CAP	1
03	SCREW	2
04	PLASTIC CAP	1
05	ST ARM	1
06	STRIPPER	1
07	SCREW	1
08	PLASTIC ST RING	1
09	SPRING PIPE	1
10	UPPER SPRING RING	1
11	ST SPRING	1
12	LOWER SPRING RING	1
13	UPPER ST DISK	1
14	DRUM	1
15	BASE ROLLER BEARING	1
16	PLASTIC SPACER	1
17	BASE ROLLER BEARING	1
18	BRONZE HALF RING	2
19	SCREW	4
20	PLASTIC WASHER	1
21	BASE	1
22	SHAFT ROLLER BEARING	1
23	HALF BRONZE RING	2
24	PLASTIC SPACER	1
25	S.STEEL SHAFT	1
26	PAWL	4
27	PAWL SPRING	4
28	S.STEEL WASHER	1
29	SEGER	1
30	PLASTIC WASHER	1
31	BRONZE GEAR "A2"	1
32	S.STEEL WASHER	1
33	BRONZE GEAR "A1"	1
34	S.STEEL CAP	1
35	SCREW	1
36	BRONZE LOWER BASE	1
37	S.STEEL PIN	1
38	PLASTIC WASHER	3
39	BRONZE GEAR "B2"	1
40	BRONZE GEAR "B1"	1
41	PLASTIC WASHER	1
42	S.STEEL SPINDLE	1
43	BRONZE GEAR "D1"	1
44	S.STEEL SPINDLE	1