

CD. 8700001112
 Amp draw: 7
 Voltage: 12V.
 Capacity: 32lt./min.
 DIAM. 38mm. HOSE

CD. 8700001124
 Amp draw: 4
 Voltage: 24V.
 DIMENSIONS: 160X120X80 mm.
 PORT CONNECTION 1 1/2" mm

CD. 8700101112
 Amp draw: 6
 Voltage: 12V.
 Capacity: 22lt./min.
 DIAM. 19mm. HOSE

CD. 8700101124
 Amp draw: 3
 Voltage: 24 V.
 DIMENSIONS: 180X120X80 mm.
 PORT CONNECTION 3/4"

APPLICATION: This pump is the ideal choice for shower drain, waste water and bilge pumping and general pumping requirements. For intermittent duty, motor may be reversed to empty bait tank. Pump has a dry prime suction lift of about 3 meters and a lift to 20 feet (6m) when primed.

BE SURE SUCTION LINES ARE AIRTIGHT.

INSTALLATION: The pump must be mounted in a dry location— even if the motor is waterproof and must not be submerged.

SELECTION OF A COOL VENTILATED location will generally extend pump motor life. 1. Mount the pump above the level of the holding tank. If this is not possible, fit a service valve on the holding tank side of the pump. This prevents waste draining into the pump during maintenance.

2. Mount the pump horizontally. 3. Direction of flow can easily be altered by loosening the screws which hold the clamping rings. Rotate the pump head to the required angle, check direction of flow and re-tighten (Fig.2).

*Note:*a) The pump is designed to work at a maximum lift/head combination of 3m (10ft). This includes height of pump above holding tank outlet and distances from pump to the highest point in the discharge line and distance of seacock discharge below waterline.

b) As the holding tanks on most boats are installed below the waterline it is essential that proper siphon breaks (vented loops) are installed to prevent

siphoning water into the toilet by leakage past the suction or discharge valves of the pump.

4. A typical installation is shown in (See drawing in back page picture n.1)

5. Position the pump in a dry, ventilated area that allows maintenance access. Fix the pump in position by attaching the screws and washers provided through the rubber feet.

ELECTRICAL CONNECTIONS: Connect black wire to negative (-) terminal of battery. The red wire should run to a properly sized (see electrical specifications) overload protected switch or circuit breaker, with a wire from switch or breaker to positive (+) terminal of battery. Electrical circuit must be independent of all other accessories. Preferred motor rotation is clockwise looking at shaft end of motor. To prolong motor life, install pump so normal motor rotation is clockwise. Use proper wire size as determined by wire table below.

Wiring must comply with applicable electrical STANDARDS. (See drawing in back page picture n.4 and n. 5)

OPERATION:PLUMBING;

1. It is recommended to use 38mm (1 1/2") smooth bore thick walled non-collapsing hose which is designed to minimise the permeation of odours.

2. To reduce the likelihood of permeation of odours, keep the hose runs as short and as straight as possible. Avoid dips in the hose which will remain wet.. Sweep connections instead of elbows should be used whenever possible.

3. Connect the inlet and outlet hose to the pump ensuring the flow direction is correct. Two stainless steel hose clamps should be used at each connection.

5. Install seacocks, deck fittings, etc. as per manufacturers recommendations.

6. Do not connect pump directly in line with a deck pumpout fitting.

OPERATION: MAINTENANCE: Check wires and connections to be sure corrosion is not adding additional resistance to the motor circuit and causing a low voltage condition at the motor. Low voltage can inhibit motor from starting and cause fuse to blow. Full voltage should be available to prevent motor damage.

Pump: Isolate power to pump and close service valve, if fitted before dismantling pump. Place a drip tray below pump head and inlet, outlet hoses during maintenance.

Valve Replacement/Inspection: 1. Disconnect the inlet and outlet hoses and unscrew outer and inner valve housings to give access to the valves.

2. The valves should be flexible and the opening silt should be closed to its relaxed state. Trapped debris in the valves or valve housings should be removed.

3. When refitting ensure the valves are assembled in the correct orientation (See drawing in back page picture n.2)

Diaphragm Replacement/Inspections: 1. Remove the pump head clamping rings by unscrewing the two clamping screws which will release the pump head and allow easy access to the diaphragm.

2. To replace/inspect diaphragm it is not necessary to disassemble valves. This will minimise spillage.

3. Remove diaphragm by undoing 8mm locking nut holding diaphragm plate against diaphragm and crank arm.

4. When re-assembling ensure that the outer edge of the diaphragm is located securely in the grooves between the body and the gear housing. Failure to do so will cause priming/vacuum creation problems. 5. It is important that the diaphragm plate is assembled with the rounded edge towards the diaphragm.

6. Refit the locking nut and clamping ring and tighten screws.

General MAINTANCE :

1. Periodically check all connection clamps for slack and corrosion and replace as necessary.

2. Use toilet cleaners made specifically for marine toilets. DO NOT USE bleach or drain cleaner. Rinse and flush the holding tank after each pump out. This will dilute any residual waste, and help prevent blockage and reduce odours.

3. Properly winterize the toilet system. As a rule it is best to leave the system completely drained and dry.

FAULT FINDING:

Pump operates but no waste pumped ? Check:

a) all connections are airtight and secure b) seacocks/valves are open c) clamping ring screws are tight and diaphragm fitted correctly d) diaphragm/valves do not need replacement.

Pump will not operate ? Check:

a) electrical connections / fuse. If fuse blows check for closed valves and blocked pipes. b) correct polarity connections to pump.

WARRANTY: Products are guaranteed two years.

No warranty will be recognized in the following cases: if the fitted instructions regarding the electrical system and the directions for use have not been properly followed

The Warranty does not cover any related installation costs involved The Warranty becomes null and void in the case of incorrect utilization

TO TAKE ADVANTAGE OF WARRANTY, ALL ARTICLES MUST BE SENT BACK COMPLETE WITH ASSEMBLING INSTRUCTIONS AND EVIDENCE OF PURCHASE.

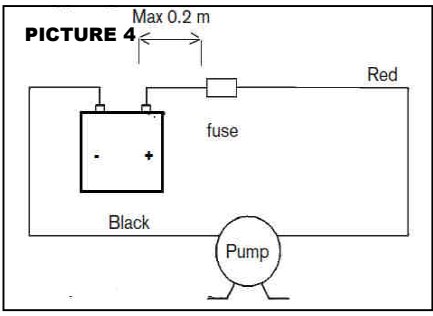
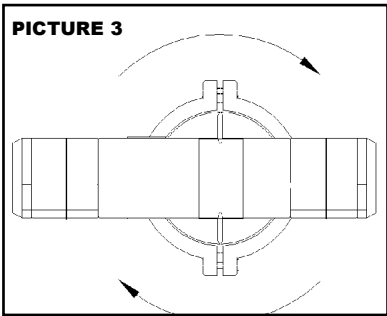
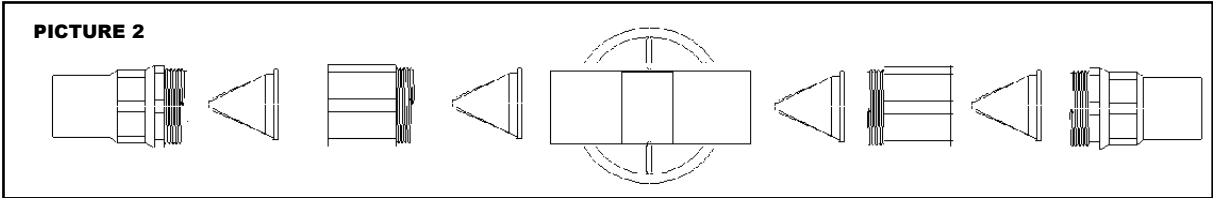
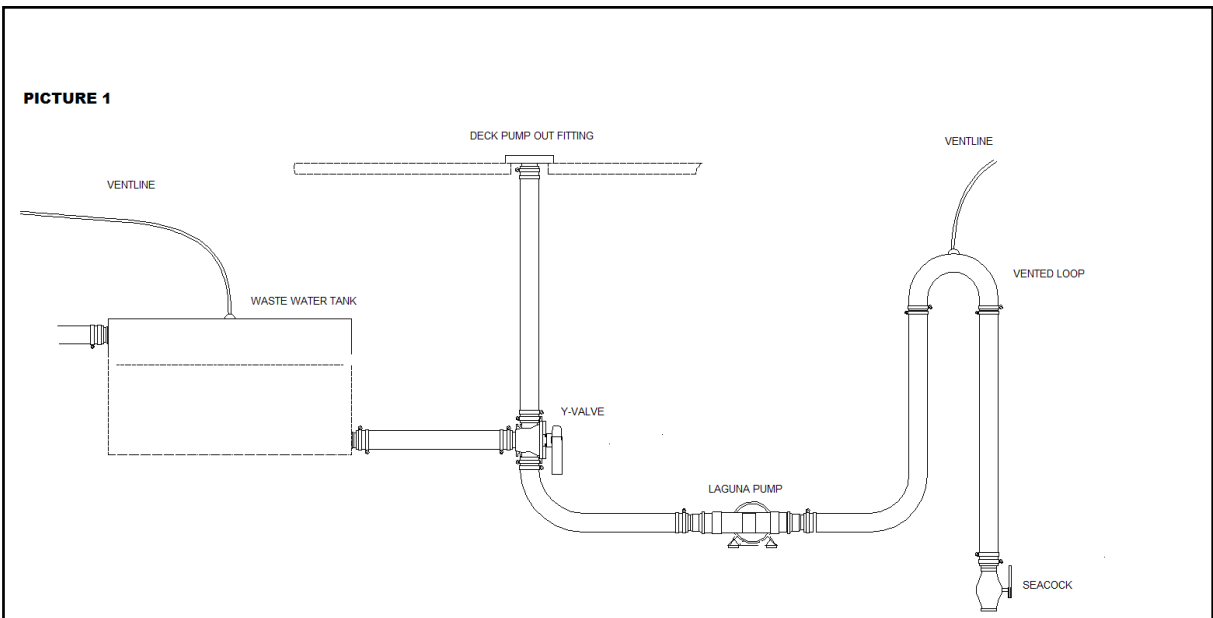



PICTURE 5
Wiring dimensions
 (Based on 10% voltage drop)

Wire size	Max wire length* in m	12V	24V
1.5 mm ² #16 AWG	20	60	
2.5 mm ² #14 AWG	30	120	

- 

This pump is designed for use with fresh water and salt water ONLY. Use with any other hazardous, caustic, or corrosive material could result in damage to the pump and the surrounding environment, possible exposure to hazardous substances and injury.
- 

Keep all wire connections above the highest water level. Wires must be joined with butt connectors and a marine grade sealant to prevent wire corrosion.
- 

Disconnect power from the system before working on the unit to avoid personal injury, damage to the surrounding environment and/or damage to the unit.
- 

Always install proper sized fuse to prevent damage to product should a short occur. Failure to install proper fuse could increase risk of pump malfunction potentially resulting in personal injury and/or fire hazard.