

Gusher Titan

Tough and Lightweight Polypropylene Models

GUSHER TITAN combines powerful performance and lightweight design



Features and Benefits

Whale's tough lightweight proven pump. A design that has been tried tested and trusted by sailors for decades.

- High flow rate: 105 ltrs (28 US gals) per minute
- Quick maintenance
 - Clamp ring easily removed for pump head rotation
- Tough, lightweight proven design
- 2 mounting options -bulkhead and thru deck models
- Suitable for use on boats over 12 m (40 ft)

5 Year Warranty

Tips It is important to ensure that a vented anti-syphon loop is incorporated in the system

Awards and Accreditations

- Suitable as a primary bilge pump on boats equal to or greater than 12 m (40ft) accordance with ISO15083

COMPLETE YOUR SYSTEM

Whale high quality bilge accessories including non-return valves, elbows and Y pieces see page 48 - 51

i Product Information

Model Specifications

	On Deck BP4402	Thru Deck / Bulkhead BP4410
Model		
Product Code		
Weight	1.5 kg (3.3 lbs)	1.85 kg (4.1 lbs)
Hose Connections	38 mm (1 1/4") Smooth Hose Connections	
Materials	Pump Body: Glass-filled Polypropylene, Clamp Ring: Acetal Diaphragm and Valves: Neoprene, (Nitrile® option available) Operating Lever: Glass-filled Nylon, Gaiter: EPDM Fasteners: Stainless Steel	
Materials In Contact With Fluid	Glass-filled Polypropylene, Acetal, Neoprene, Nitrile®	
Service Kits	AK4400 - Neoprene Parts AK4419 - Nitrile® Parts for Oil and Diesel Contains: Diaphragm, Valves, Seals AK4400 - Whale Gusher Titan Neoprene (for on deck installations) - diaphragm, valves and fixings AK4419 - Whale Gusher Titan Nitrile® (for below deck installations) - diaphragm, valves and fixings AS4406 - Whale Gusher Titan - Standard Lever Kit AS4407 - Whale Gusher Titan - Standard Clamping Ring Kit AS4408 - Whale Gusher Titan- Operating Lever U/Deck AS4409 - Whale Gusher Titan - UnderDeck Clamping Ring Kit AS4412 - Whale Gusher Titan - Clamping Plate Kit AS3725 - Gaiter Kit For Deckplates (for underdeck models - Gusher 30 and 10, Titan, Urchin, MarkV)	
Accessories	DP8904 - Deck Plate Kit for BP4410 only AS4405 - Spare Handle	
Maximum Suction Lift	4 m (13.5 ft)	
Maximum Discharge Head	4 m (13.5 ft)	

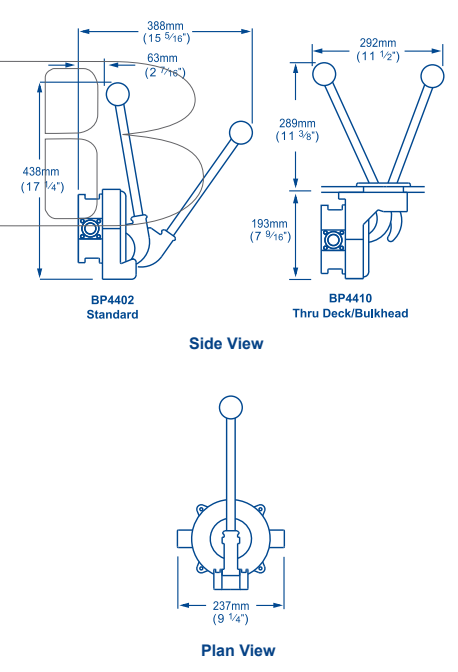

Performance Data

	BP4402 / BP4410	BP4402 / BP4410
Suction Lift	1 m (3 ft)	2 m (6 ft)
Discharge Head	0.5 m (1.5 ft)	0.5 m (1.5 ft)
45 Strokes per Minute	67 ltrs (18 US gals)	65 ltrs (17 US gals)
70 Strokes per Minute	105 ltrs (28 US gals)	98 ltrs (26 US gals)

Note: These specifications are retail items only. For details of our bulk pack range for boat builders and wholesalers - contact Whale Support.

