

# **Vetus<sup>®</sup>**

*Installatie instructies*  
*Installation instructions*  
*Installationsvorschriften*  
*Instructions d'installation*  
*Instrucciones de instalación*  
*Istruzioni per l'installazione*

<b>NEDERLANDS</b>	<b>2</b>
<b>ENGLISH</b>	<b>4</b>
<b>DEUTSCH</b>	<b>6</b>
<b>FRANÇAIS</b>	<b>8</b>
<b>ESPAÑOL</b>	<b>10</b>
<b>ITALIANO</b>	<b>12</b>

**Flexibele schroefaskoppeling**

**Flexible propeller shaft coupling**

**Flexible Schraubenwellenkupplung**

**Accouplement flexible d'arbre porte-hélice**

**Acoplamiento flexible del árbol porta-hélice**

**Giunto di accoppiamento flessibile dell'albero dell'elica**



## **Bullflex**

## Opstelling

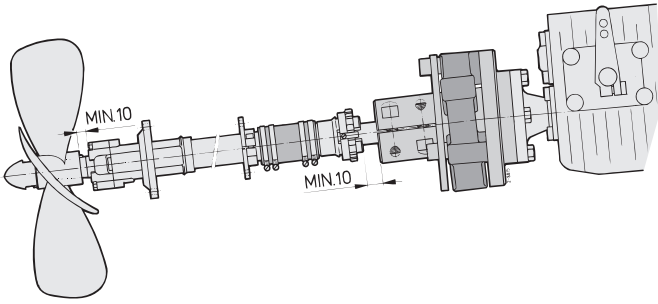

In verband met de axiale beweging van de schroefas moet er tussen het buitenlager en de naaf van de schepsschroef een minimale vrije ruimte zijn. ◀

## Stuwkracht

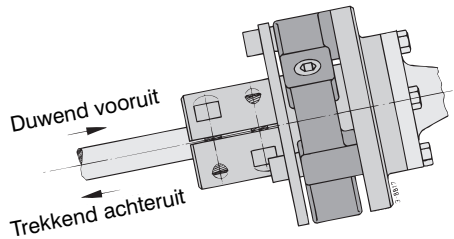

N.B. Bij vooruit varen moet het rubberdeel worden ingedrukt. ◀

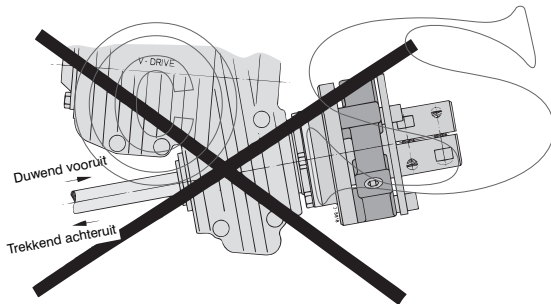

Toepassing van de Bullflex in combinatie met een V-drive keerkoppeling is niet toegestaan! ◀

## Afwijkende (grotere) schroefasdiameter

Verklein de schroefasdiameter over de lengte van de klembus (afmeting 'A') naar afmeting 'd' van de koppeling, zie Hoofdafmetingen. Radius 'r' minimaal 2 mm. ◀

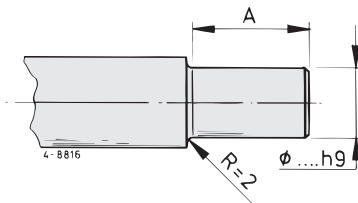

## Uitlijnfout

De maximaal toelaatbare uitlijnfout van de schroefas is 2°. ◀

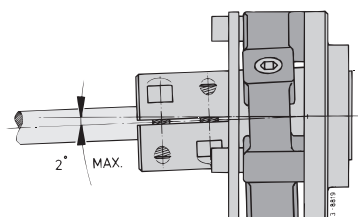

## Centreer-ring

Een scheepsmotor op flexibele motorsteunen 'danst' altijd.

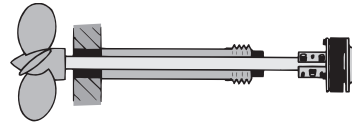

Is de schroefas door één vast lager ondersteund dan fungeert de Bullflex koppeling -mét de centreer-ring- als flexibel kogelgewricht, zie A. ◀

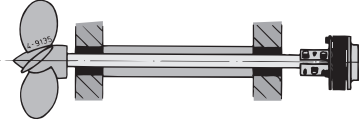

In het geval dat de schroefas star is opgesteld -dus door 2 (of meer) vaste lagers wordt ondersteund- dan moet de schroefas niet beïnvloed kunnen worden door de motorbewegingen. Verwijder in dat geval de centreer-ring, zie B. ◀

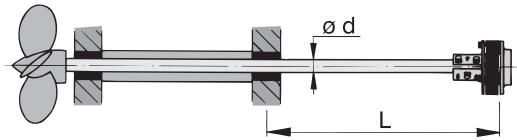

Wanneer de lengte 'L' van de schroefas tussen het binnenste vaste lager en de flens van de keerkoppeling meer is dan 20 x de schroefasdiameter 'd', verwijder dan **niet** de centreerring. ◀

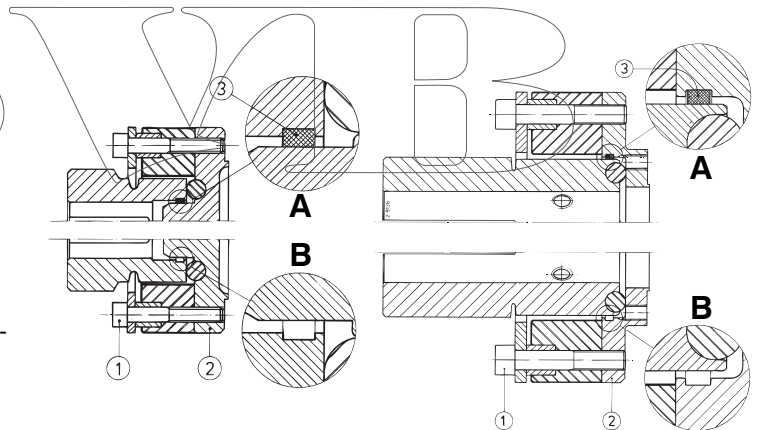

Bullflex 1

Bullflex 2, 4, 8, 12, 16, 32

## Verwijderen centreer-ring:

Neem de bouten ① los. Neem de flens ② los van de naaf en verwijder de centreer-ring ③. Plaats de flens terug en monteer de bouten (met een borgmiddel, LOCTITE 222 Screwlock) en trek ze aan met het opgegeven aanhaal moment 'T1', zie tabel. Zorg er voor dat de gaten in de flens en in het rubberelement tijdens de montage van de bouten in lijn liggen. Vervorm hiervoor het rubberelement met behulp van een lijmtang. ◀

Bullflex		T1
1	M8	25 Nm
2	M10	50 Nm
4	M12	90 Nm
8	M14	140 Nm
12	M16	220 Nm
16	M16	220 Nm
32	M20	430 Nm

## Montage algemeen

Om een betrouwbaar functionerende koppeling te verkrijgen dienen alle bouten en moeren met de opgegeven momenten te worden aangetrokken. Gebruik hiervoor een momentsleutel; het 'op gevoel' aantrekken leidt niet tot bevredigende resultaten. ◀

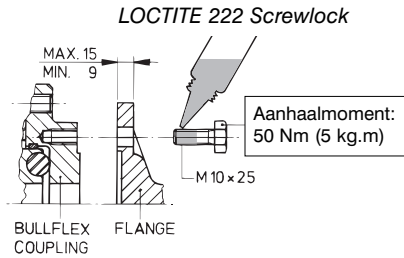
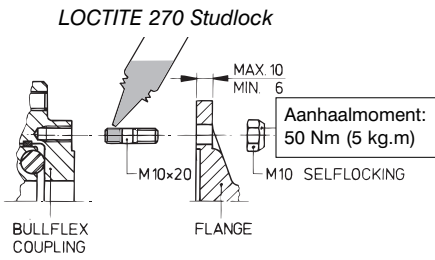

Bullflex		T2
1	M10x30	60 Nm
2	M10x35	60 Nm
4	M12x40	100 Nm
8	M14x45	200 Nm
12	M16x50	320 Nm
16	M16x55	230 Nm
32	M20x70	450 Nm

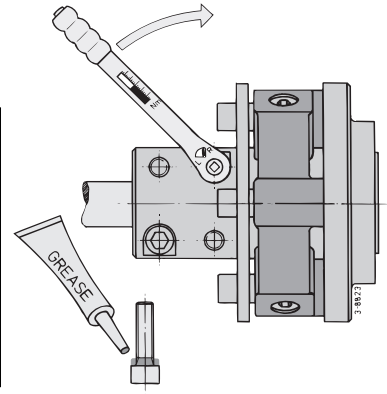

Trek de bouten aan met het opgegeven aanhaalmoment 'T2', zie tabel. ◀

De schroefas dient over de lengte (L) in de naaf te zijn gestoken en as en de naaf dienen vrij van vet en vuil (\*) te zijn. ◀

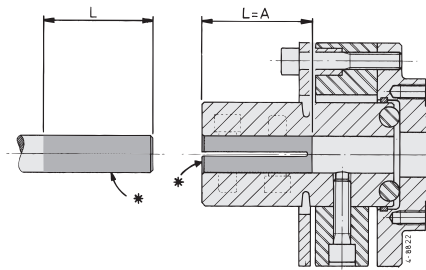

Zorg er voor dat de rubberdelen niet worden aangetast door oplosmiddelen. ◀

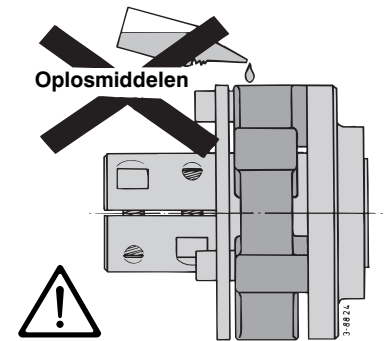

## Technische gegevens

Bullflex		1	2	4	8	12	16	32	
Max. koppel volgens	DIN6270B	75	150	300	600	900	1200	2200	N.m
		7,6	15	30	61	92	122	220	kgf.m
	DIN6270A	45	90	200	410	540	935	1780	N.m
		4,6	9	20	42	55	95	178	kgf.m
Max. vermogen volgens	DIN6270B	0,8	1,6	3,1	6,3	9,4	12,6	23,0	kW/100 min <sup>-1</sup>
		1.1	2.1	4.3	8.5	12.8	17.1	31.3	hp/100 RPM
	DIN6270A	0,5	0,9	2,1	4,3	7,1	9,8	18,6	kW/100 min <sup>-1</sup>
		0.6	1.3	2.8	5.8	9.6	13.3	25.3	hp/100 RPM
Massatraagheidsmoment	J	23·10 <sup>-4</sup>	57·10 <sup>-4</sup>	158·10 <sup>-4</sup>	300·10 <sup>-4</sup>	595·10 <sup>-4</sup>	710·10 <sup>-4</sup>	2058·10 <sup>-4</sup>	kg.m <sup>2</sup>
	GD <sup>2</sup>	0,009	0,023	0,063	0,12	0,23	0,28	0,82	kgf.m <sup>2</sup>
Dyn. torsiestijfheid		460	820	1850	6850	10900	13700	24400	N.m/rad
		12,46	6,99	3,10	0,84	0,52	0,42	0,23	°/100 N.m
Axiale drukstijfheid		1,3	3,2	3,9	5,3	6,5	6,7	7,9	kN/mm
		133	331	395	542	665	678	804	kgf/mm
Axiale trekstijfheid		0,05	0,05	0,07	0,37	0,43	0,57	0,43	kN/mm
		5	5	7	38	44	58	44	kgf/mm
Maximale hoekverplaatsing		2°	2°	2°	2°	2°	2°	2°	
Max. toerental bij	2°	3500	3250	3000	2500	2000	2000	1800	min <sup>-1</sup> , RPM
	0°	7000	6500	6000	5000	4000	4000	3600	
Max. stuwkracht		2000	5000	5000	8000	9000	10000	20000	N
		204	510	510	816	917	1020	2040	kgf
Gewicht, ca.		3	4,5	6,9	12	17	19	38	kg

## Mounting

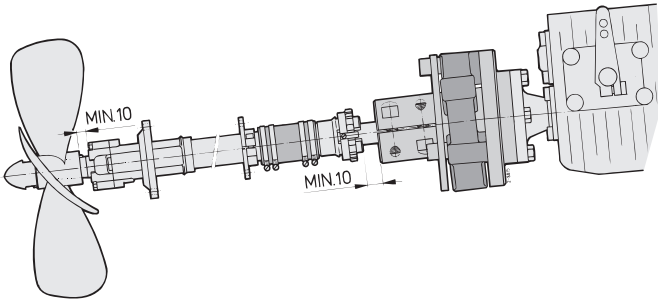

In connection with the axial movement of the propeller shaft a minimum free space between outer bearing and propeller hub is required. ◀

## Propeller-thrust

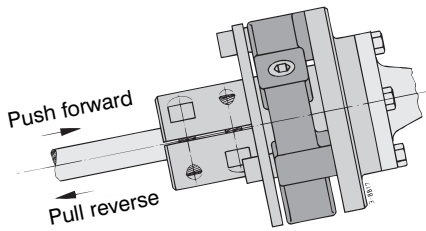

N.B. When sailing in forward direction the rubber part must be compressed. ◀

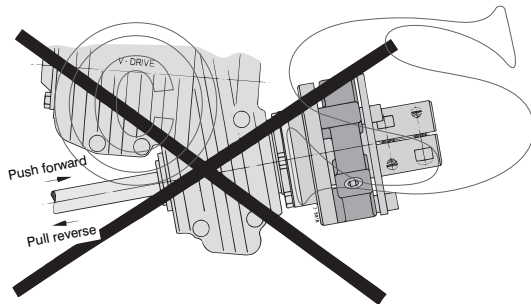

Using the Bullflex in combination with a V-drive type gearbox is not allowed! ◀

## Over-size (larger) propeller shaft diameter

Reduce the propeller shaft diameter for the taper length (dimension 'A') to the given dimension 'd' of the coupling, see Overall dimensions. Radius 'r' minimal 2 mm (0.08"). ◀

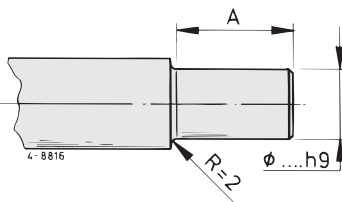

## Misalignment

The maximum allowable misalignment of the propeller shaft is 2°. ◀

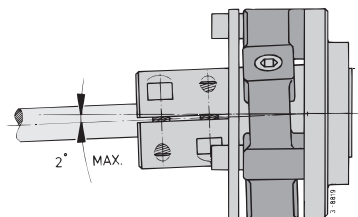

## Centering ring

An engine on flexible mountings will, by definition, always bounce. ◀

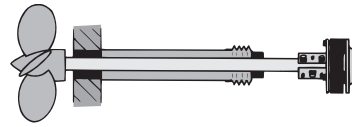

Where the propeller shaft is supported by one rigid bearing only, the Bullflex coupling -with the centering ring installed- will function as a flexible ball joint, see A. ◀

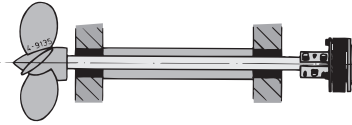

When the propeller shaft is installed rigidly which means to say -supported by two (or more) non-flexible bearings- the propeller shaft should not be affected by engine movements. Therefore remove the centering ring in such an installation, see B. ◀

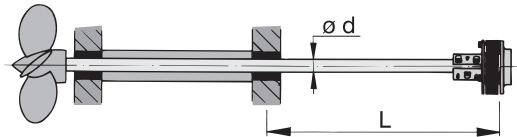

If the length 'L' of the propeller shaft between the inner rigid bearing and the flange of the gearbox is more than 20 times the propeller shaft diameter 'd', do not remove the centering ring. ◀

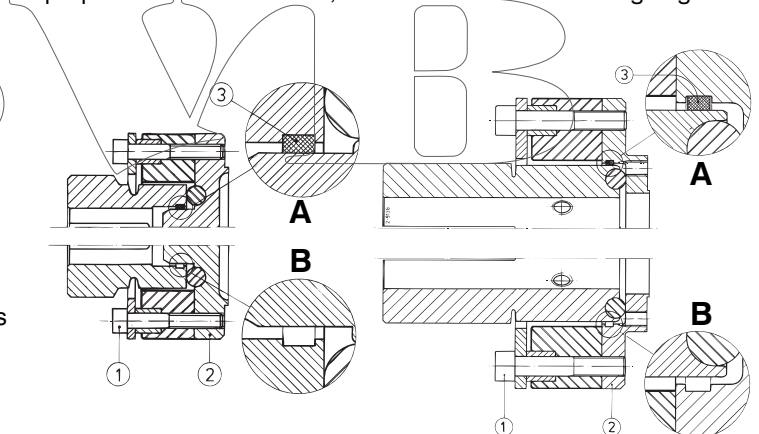

## Removal of centering ring:

Detach the bolts ①. Detach flange ② from the hub and remove centering ring ③. Attach flange and reinstall the bolts (with a locking agent, LOCTITE 222 Screwlock) and tighten with the specified torque 'T1' see table. Ensure that the holes in flange and rubber element are in line during installation of the bolts. Deform the rubber element with the assistance of a screw clamp. ◀

Bullflex		T1
1	M8	25 Nm
2	M10	50 Nm
4	M12	90 Nm
8	M14	140 Nm
12	M16	220 Nm
16	M16	220 Nm
32	M20	430 Nm

**General assembly**

To achieve a reliably operating coupling all the bolts and nuts must be tightened with the torques given. Use a torque wrench; tightening it 'in the blind' will not lead to satisfying results. ◀

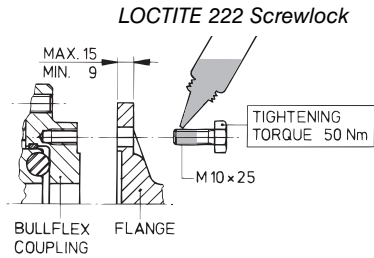
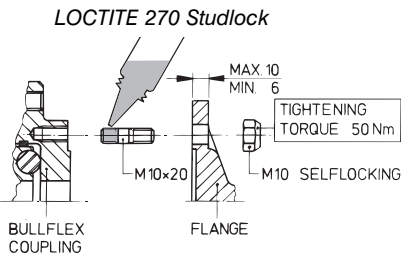

Bullflex		T2
1	M10x30	60 Nm
2	M10x35	60 Nm
4	M12x40	100 Nm
8	M14x45	200 Nm
12	M16x50	320 Nm
16	M16x55	230 Nm
32	M20x70	450 Nm

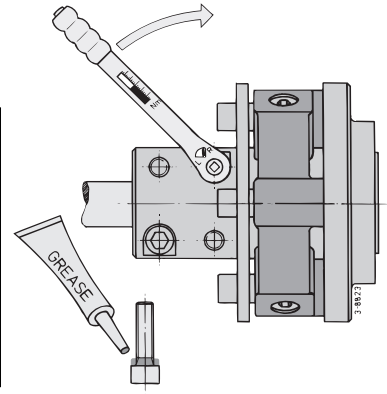

Tighten the bolts with the specified torque 'T2', see table. ◀

The propeller shaft must be inserted into the hub for a sufficient length (L) and the shaft and hub must be free of grease and dirt (\*). ◀

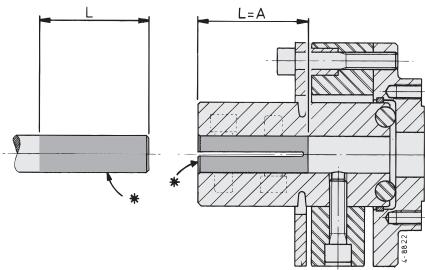

Take care that the rubber parts are not affected by solvents. ◀

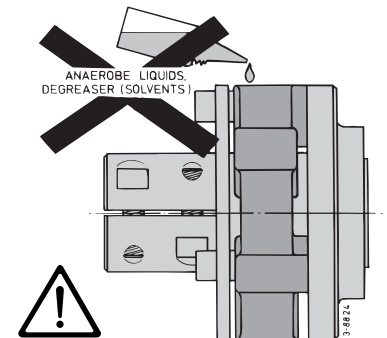

**Technical data**

Bullflex		1	2	4	8	12	16	32	
Max. torque to	DIN6270B	75	150	300	600	900	1200	2200	N.m
		55	110	221	442	663	885	1622	lbs.ft
	DIN6270A	45	90	200	410	540	935	1780	N.m
		33	66	147	302	400	690	1313	lbs.ft
Max. power to	DIN6270B	0,8	1,6	3,1	6,3	9,4	12,6	23,0	kW/100 min <sup>-1</sup>
		1.1	2.1	4.3	8.5	12.8	17.1	31.3	hp/100 RPM
	DIN6270A	0,5	0,9	2,1	4,3	7,1	9,8	18,6	kW/100 min <sup>-1</sup>
		0.6	1.3	2.8	5.8	9.6	13.3	25.3	hp/100 RPM
Mass moment of inertia	J	23·10 <sup>-4</sup>	57·10 <sup>-4</sup>	158·10 <sup>-4</sup>	300·10 <sup>-4</sup>	595·10 <sup>-4</sup>	710·10 <sup>-4</sup>	2058·10 <sup>-4</sup>	kg.m <sup>2</sup>
	GD <sup>2</sup>	0,009	0,023	0,063	0,12	0,23	0,28	0,82	kgf.m <sup>2</sup>
Dyn. torsion stiffness		460	820	1850	6850	10900	13700	24400	N.m/rad
		16.88	9.47	4.20	1.13	0.7	0.57	0.32	°/100 lbs.ft
Axial push stiffness		1,3	3,2	3,9	5,3	6,5	6,7	7,9	kN/mm
		0.0134	0.0054	0.0045	0.0033	0.0027	0.0026	0.0022	inch/100 lbs
Axial pull stiffness		0,05	0,05	0,07	0,37	0,43	0,57	0,43	kN/mm
		0.35	0.35	0.26	0.05	0.041	0.03	0.041	inch/100 lbs
Maximum angular displacement			2°	2°	2°	2°	2°	2°	2°
Max. rpm at	2°	3500	3250	3000	2500	2000	2000	1800	min <sup>-1</sup> , RPM
	0°	7000	6500	6000	5000	4000	4000	3600	
Max. thrust force		2000	5000	5000	8000	9000	10000	20000	N
		204	510	510	816	917	1020	2040	kgf
		450	1124	1124	1798	2023	2248	4496	lbs
Weight, approx.		3	4,5	6,9	12	17	19	38	kg
		6.7	9.9	15.2	26.5	37.5	41.9	83.8	lbs

## Aufstellung

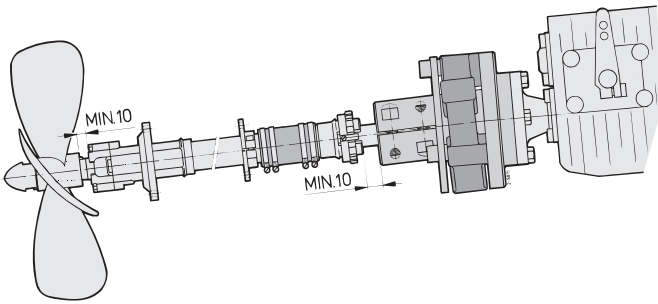

Aufgrund der Axialbewegung der Schraubenwelle muß zwischen dem äußeren Wellenlager und der Nabe der Schiffsschraube ein minimaler freier Raum sein. ◀

## Schubkraft

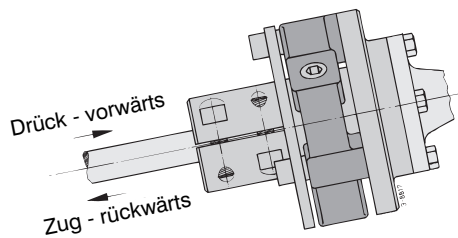

Achtung: Beim Vorwärtsfahren soll das Gummitel zusammengedrückt werden. ◀

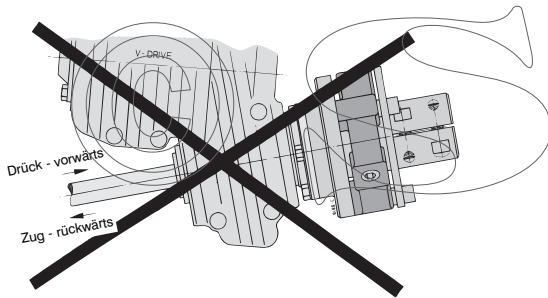

Der Einsatz der Bullflex in Kombination mit einem Vdrive-Wendegetriebe ist nicht gestattet! ◀

## Abweichender (größerer) Durchmesser der schraubenwelle

Den Durchmesser der Schraubenwelle über die Länge der Klemmbuchse (Maß 'A') auf Maß 'd' der Kupplung verkleinern, siehe Hauptmaße. Radius 'r' sollte mindestens 2 mm betragen. ◀

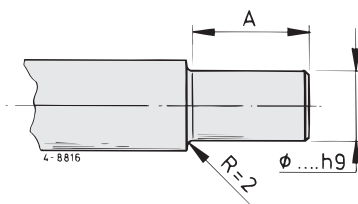

## Versatz

Der max. zulässiger Versatz der Schraubenwelle beträgt 2°. ◀

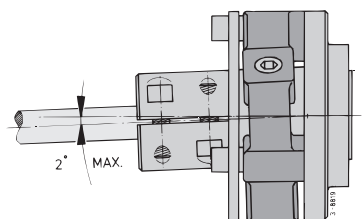

## Zentrierung

Ein Schiffsmotor auf flexiblen motorstützen 'tanzt' immer.

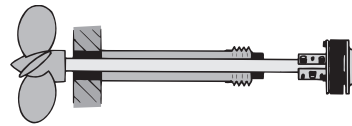

Wenn die Schraubenwelle durch ein festes Lager unterstützt wird, dann fungiert die BULLFLEX Kupplung (mit Zentrierung) als flexibles Kugelgelenk, siehe A. ◀

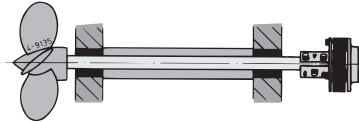

Wenn die Schraubenwelle starr montiert - also mit zwei oder mehr festen Lagern unterstützt - ist, darf die Schraubenwelle nicht durch die Motorbewegungen beeinflusst werden können, siehe B. ◀

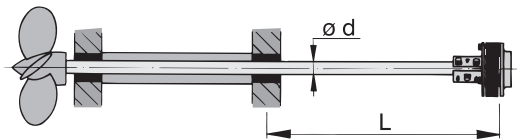

Wenn die Länge 'L' der Schraubenwelle zwischen dem innersten festen Lager und dem Flansch der Umkehrkupplung mehr als 20 x so groß ist wie der Schraubenwelldurchmesser 'd', dann den Zentrierring **nicht** entfernen. ◀

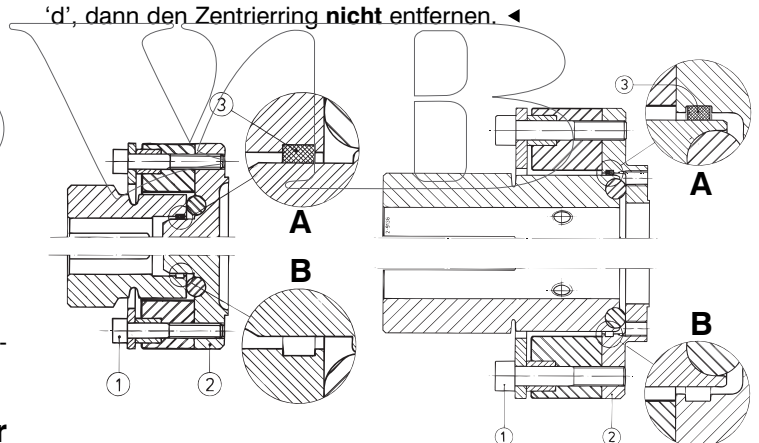

Bullflex 1

Bullflex 2, 4, 8, 12, 16, 32

## Entfernen Zentrierung:

Machen Sie die Bolzen ① los, machen Sie den Flansch ② los der Nabe und entfernen Sie den Zentrierung ③. Stellen Sie den Flansch zurück und montieren Sie die Bolzen (mit einem Sicherungsmittel, Locktite 222 Screwlock) und Ziehen Sie die Bolzen an mit der angegebenen Torsion 'T1', siehe Tabelle. Sorgen Sie dafür daß die Löcher im Flansch und im Gummi-element in einer Flucht liegen während der Montage der Bolzen. Formen Sie dazu das Gummi-element um mit Hilfe eines Leimknechtes. ◀

Bullflex		T1
1	M8	25 Nm
2	M10	50 Nm
4	M12	90 Nm
8	M14	140 Nm
12	M16	220 Nm
16	M16	220 Nm
32	M20	430 Nm

## Montage allgemein

Damit eine zuverlässig funktionierende Kupplung erreicht wird, sollten alle Bolzen und Muttern nach den angegebenen Drehmomenten angezogen werden.

Verwenden Sie dazu einen Drehmomentschlüssel; das 'Anziehen nach Gefühl' führt nicht zu befriedigenden Ergebnissen. ◀

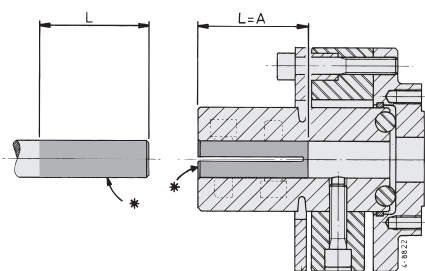
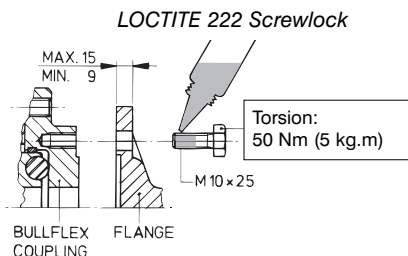
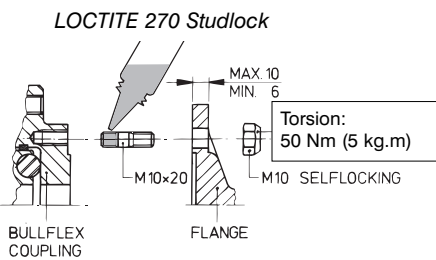

Die Schraubenwelle muß über genügenden Länge (L) in der Klemmnabe und Schraubenwelle müssen schmutz- und fettfrei sein (\*). ◀

Bullflex		T2
1	M10x30	60 Nm
2	M10x35	60 Nm
4	M12x40	100 Nm
8	M14x45	200 Nm
12	M16x50	320 Nm
16	M16x55	230 Nm
32	M20x70	450 Nm

Ziehen Sie die Bolzen an mit der angegebenen Torsion 'T2', siehe Tabelle. ◀

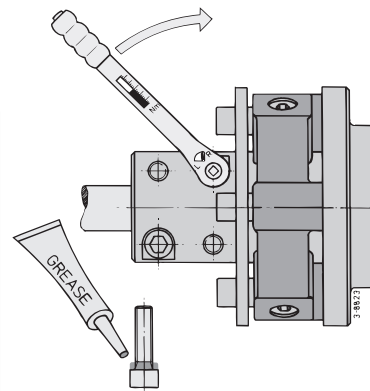

Sorgen Sie dafür, daß die Gummitteile nicht von Lösungsmitteln angegriffen werden. ◀

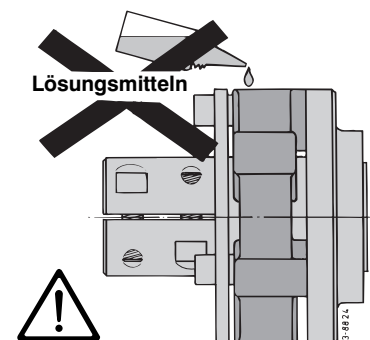

## Technische Daten

Bullflex		1	2	4	8	12	16	32	
Max. Drehmoment gemäß	DIN6270B	75	150	300	600	900	1200	2200	N.m
	DIN6270A	7,6	15	30	61	92	122	220	kgf.m
Max. Leistung gemäß	DIN6270B	45	90	200	410	540	935	1780	N.m
	DIN6270A	4,6	9	20	42	55	95	178	kgf.m
Max. Leistung gemäß	DIN6270B	0,8	1,6	3,1	6,3	9,4	12,6	23,0	kW/100 min <sup>-1</sup>
	DIN6270A	1,1	2,1	4,3	8,5	12,8	17,1	31,3	hp/100 RPM
Massenträgheitsmoment	J	23·10 <sup>-4</sup>	57·10 <sup>-4</sup>	158·10 <sup>-4</sup>	300·10 <sup>-4</sup>	595·10 <sup>-4</sup>	710·10 <sup>-4</sup>	2058·10 <sup>-4</sup>	kg.m <sup>2</sup>
	GD <sup>2</sup>	0,009	0,023	0,063	0,12	0,23	0,28	0,82	kgf.m <sup>2</sup>
Dyn. Drehsteifigkeit		460	820	1850	6850	10900	13700	24400	N.m/rad
		12,46	6,99	3,10	0,84	0,52	0,42	0,23	°/100 N.m
Axiale steifigkeit druck		1,3	3,2	3,9	5,3	6,5	6,7	7,9	kN/mm
		133	331	395	542	665	678	804	kgf/mm
Axiale steifigkeit zug		0,05	0,05	0,07	0,37	0,43	0,57	0,43	kN/mm
		5	5	7	38	44	58	44	kgf/mm
Max. Winkelverschiebung		2°	2°	2°	2°	2°	2°	2°	
Max. Drehzahl bei	2°	3500	3250	3000	2500	2000	2000	1800	min <sup>-1</sup> , RPM
	0°	7000	6500	6000	5000	4000	4000	3600	
Max. Triebkraft		2000	5000	5000	8000	9000	10000	20000	N
		204	510	510	816	917	1020	2040	kgf
Gewicht, ca.		3	4,5	6,9	12	17	19	38	kg

## Montage

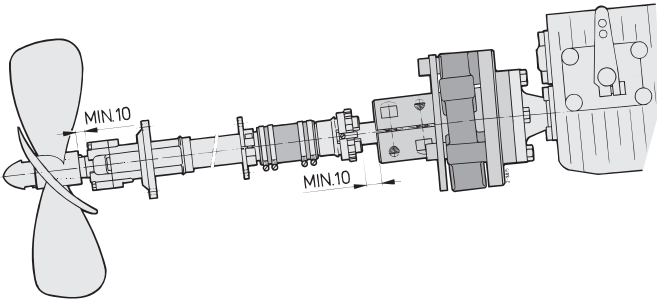

Etant donné le mouvement axial de l'arbre porte-hélice, il est nécessaire de laisser un espace libre minimum entre le support extérieur et le moyeu de l'hélice. ◀

## Force de propulsion

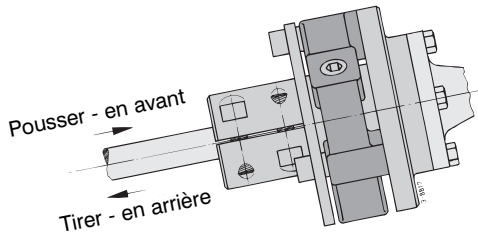

N.B. Lors de la marche avant, la partie caoutchouc doit être comprimée. ◀

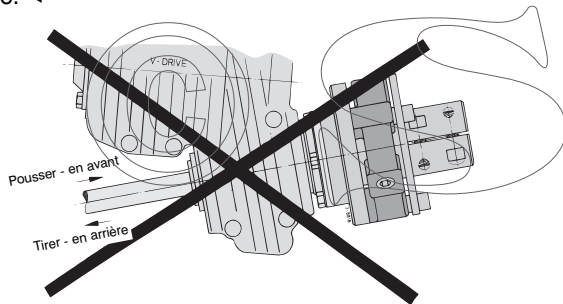

Il est interdit d'utiliser le Bullflex en combinaison avec un inverseur à entraînement en V ! ◀

## Autre diamètre (plus grand) de l'arbre porte-hélice

Réduire, sur la longueur de la bague de serrage (dimension 'A'), le diamètre de l'arbre porte-hélice à la dimension 'd' du couplage. Voir les dimensions principales. Rayon 'r' minimum 2 mm. ◀

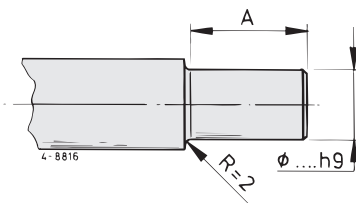

## Desalignement

Le désalignement maximum autorisé de l'arbre porte-hélice est de 2°. ◀

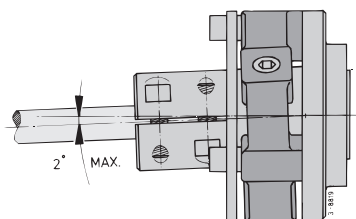

## Anneau de centrage

Le moteur 'danse' toujours sur les supports moteur très flexibles.

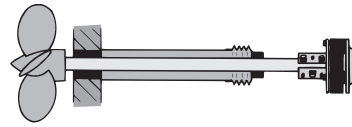

Dans le cadre d'une installation de ligne d'arbre avec une seule bague rigide, le BULLFLEX (avec l'anneau de centrage) se conduira comme un joint à rotule flexible, voir A. ◀

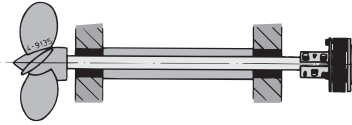

Lorsque la ligne d'arbre est installée de manière rigide - maintenue par deux ou trois bagues rigides - celle-ci ne sera pas affectée par les mouvements du moteur, voir B. ◀

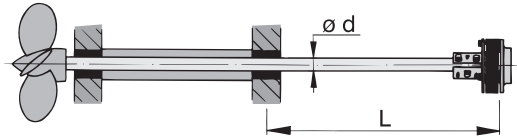

Si la longueur 'L' de l'arbre porte-hélice entre le palier intérieur fixe et la bride d'accouplement d'inversion est supérieure à 20 fois le diamètre de l'arbre porte-hélice 'd', alors l'anneau de centrage **n'est pas supprimé**. ◀

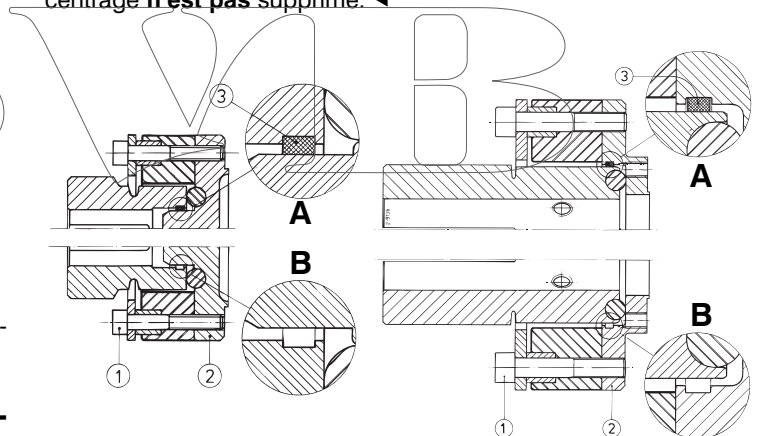

Bullflex 1

Bullflex 2, 4, 8, 12, 16, 32

## Supprimer anneau de centrage:

Enlever les boulons ①. Enlever le tourteau ② du moyeu et supprimer l'anneau de centrage ③. Remettre le tourteau et monter les boulons (à l'aide d'un produit de verrouillage, LOCKTITE 222 Screwlock) et les attirer à l'aide de la torsion, indiquée sous 'T1', voir table. Assurer que les trous dans le tourteau et dans l'élément caoutchouc sont alignés durant le montage des boulons. Pour faire ceci, tordre l'élément caoutchouc à l'aide d'un sergent. ◀

Bullflex		T1
1	M8	25 Nm
2	M10	50 Nm
4	M12	90 Nm
8	M14	140 Nm
12	M16	220 Nm
16	M16	220 Nm
32	M20	430 Nm



## Assemblage generalites

Pour obtenir un accouplement au fonctionnement fiable, il est nécessaire de serrer tous les boulons et écrous selon les moments indiqués. Utiliser pour cela une clef dynamométrique; un serrage approximatif ne donne pas de résultats satisfaisants. ◀

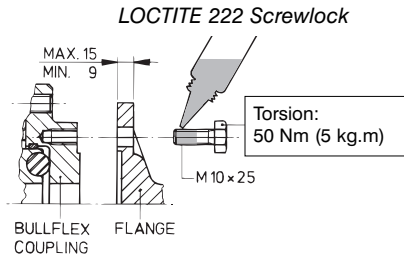
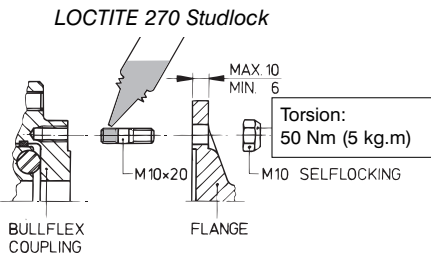

Bullflex		T2
1	M10x30	60 Nm
2	M10x35	60 Nm
4	M12x40	100 Nm
8	M14x45	200 Nm
12	M16x50	320 Nm
16	M16x55	230 Nm
32	M20x70	450 Nm

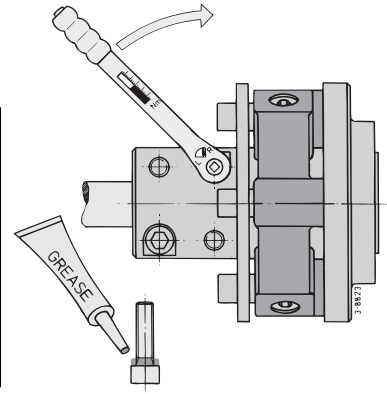

Attirer les boulons à l'aide de la torsion, indiquée sous 'T2', voir table. ◀

L'arbre de l'hélice doit être mis dans le moyeu de longueur (L) suffisante. Veiller à ce que l'arbre et le moyeu soient exempts de graisse et de saleté (\*). ◀

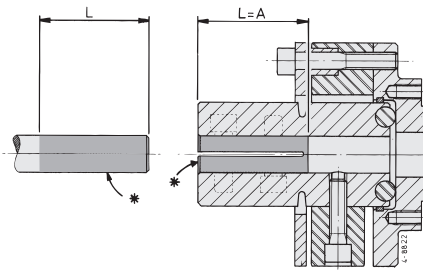

Veiller à ce que les parties caoutchouc ne soient pas attaquées par des solvants. ◀

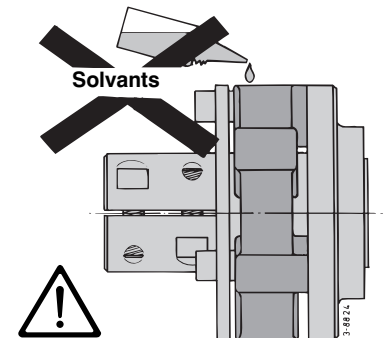

## Specifications techniques

Bullflex		1	2	4	8	12	16	32	
Couple max. selon	DIN6270B	75	150	300	600	900	1200	2200	N.m
	DIN6270A	7,6	15	30	61	92	122	220	kgf.m
Puissance max. selon	DIN6270B	45	90	200	410	540	935	1780	N.m
	DIN6270A	4,6	9	20	42	55	95	178	kgf.m
Moment d'inertie	J	23·10 <sup>-4</sup>	57·10 <sup>-4</sup>	158·10 <sup>-4</sup>	300·10 <sup>-4</sup>	595·10 <sup>-4</sup>	710·10 <sup>-4</sup>	2058·10 <sup>-4</sup>	kg.m <sup>2</sup>
	GD <sup>2</sup>	0,009	0,023	0,063	0,12	0,23	0,28	0,82	kgf.m <sup>2</sup>
Rigidite dyn. a la torsion		460	820	1850	6850	10900	13700	24400	N.m/rad
		12,46	6,99	3,10	0,84	0,52	0,42	0,23	°/100 N.m
Rigidite axiale a la compression		1,3	3,2	3,9	5,3	6,5	6,7	7,9	kN/mm
		133	331	395	542	665	678	804	kgf/mm
Rigidite axiale a la traction		0,05	0,05	0,07	0,37	0,43	0,57	0,43	kN/mm
		5	5	7	38	44	58	44	kgf/mm
Le deplacement angulaire max.			2°	2°	2°	2°	2°	2°	2°
Nombre de tours max. á	2°	3500	3250	3000	2500	2000	2000	1800	min <sup>-1</sup> , RPM
	0°	7000	6500	6000	5000	4000	4000	3600	
Poussée max.		2000	5000	5000	8000	9000	10000	20000	N
		204	510	510	816	917	1020	2040	kgf
Poids, environ		3	4,5	6,9	12	17	19	38	kg

## Montaje

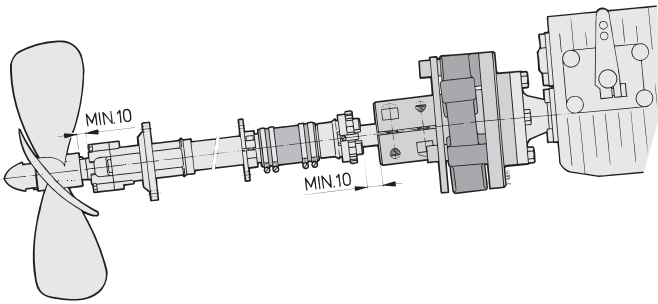

Dado el movimiento axial del árbol porta-hélice, es necesario dejar un espacio libre mínimo entre el soporte exterior y el cubo de hélice. ◀

## Fuerza de propulsión

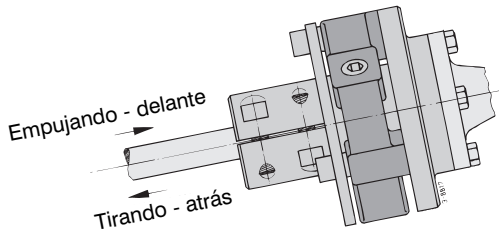

Nota: ¡Navegando hacia delante la parte de caucho se debe comprimir! ◀

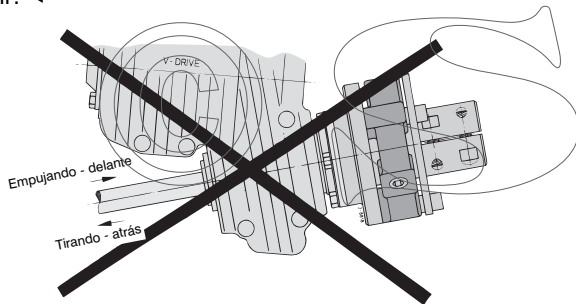

¡No se permite aplicar el Bullflex en combinación con la caja de velocidades del tipo de transmisión en V! ◀

## Otro diámetro (mayor) del árbol porta-hélice

Redúzcase el diámetro del árbol porta-hélice a lo largo del cono (dimensión 'A') hacia dimensión 'd' del acoplamiento, véanse las Dimensiones Principales. El radio 'r' será de 2 mm como mínimo. ◀

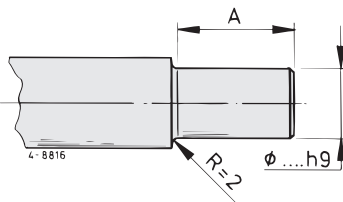

## Mal alineamiento

Se admite un mal alineamiento máximo de 2° del árbol porta-hélice. ◀

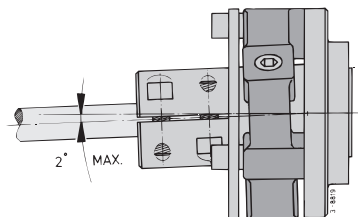

## Anillo centrador

Un motor de embarcación por definición siempre 'bailará' sobre los soportes motor flexibles.

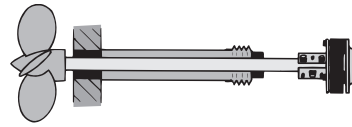

Cuando el árbol porta-hélice se apoya en un solo cojinete rígido, el acoplamiento Bullflex - con el anillo centrador instalado - funcionará como una articulación esférica, véanse A. ◀

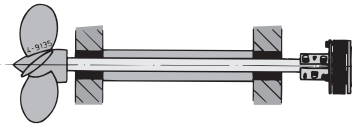

Cuando el árbol porta-hélice está instalado de forma rígida, o sea, cuando se apoya en dos (o más) cojinetes no flexibles, el árbol porta-hélice no puede verse afectado por los movimientos del motor. Retírese para ello el anillo centrador, veanse B. ◀

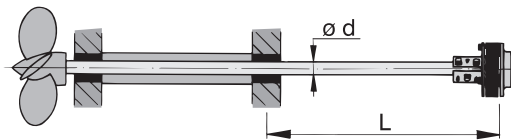

Si el largo 'L' del árbol porta-hélice entre el cojinete fijo más interior y la brida de la caja de velocidades es superior a 20 veces el diámetro del árbol porta-hélice 'd', **no** retire el anillo centrador. ◀

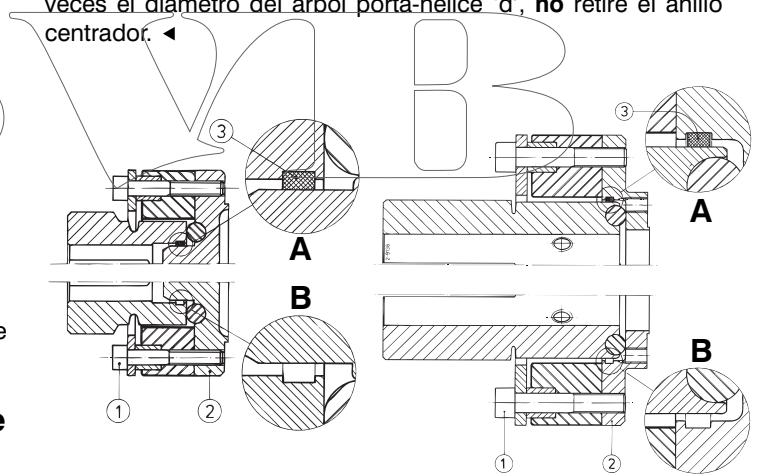

Bullflex 1

Bullflex 2, 4, 8, 12, 16, 32

## Retirar el anillo centrador:

Soltar los tornillos ①. Soltar la brida ② del cubo y retirar el anillo centrador ③. Volver a poner la brida en su sitio y montar los tornillos (con un producto de bloqueo LOCTITE 222 Screwlock) y apretar según el par indicado 'T1', véase la tabla. Asegurar que los orificios de la brida y el elemento de caucho quedarán en línea durante el montaje de los tornillos. Deformar para ello el elemento de caucho con ayuda de una mordaza de tornillo. ◀

Bullflex		T1
1	M8	25 Nm
2	M10	50 Nm
4	M12	90 Nm
8	M14	140 Nm
12	M16	220 Nm
16	M16	220 Nm
32	M20	430 Nm

## Montaje en general

Para obtener un acoplamiento de funcionamiento fiable se apretarán todos los tornillos y tuercas según los pares indicados. Utilizar para ello una llave de torsión; apretar 'a tuestas' no dará resultados satisfactorios. ◀

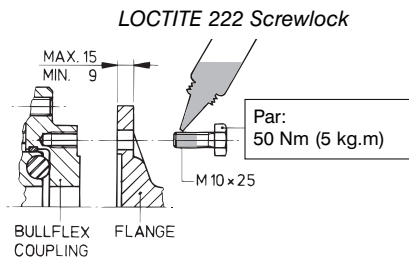
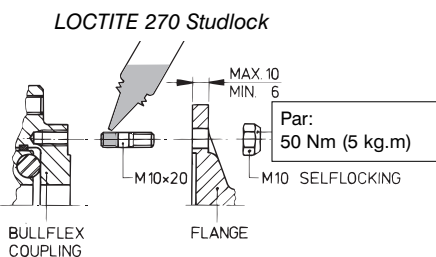

Bullflex		T2
1	M10x30	60 Nm
2	M10x35	60 Nm
4	M12x40	100 Nm
8	M14x45	200 Nm
12	M16x50	320 Nm
16	M16x55	230 Nm
32	M20x70	450 Nm

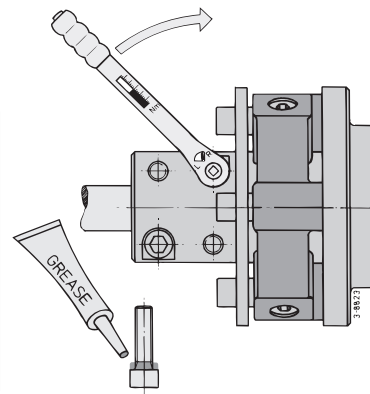

Apretar los tornillos observando el par indicado 'T2', véase la tabla. ◀

El árbol porta-hélice se insertará con un largo (L) suficiente en el cubo y el árbol y cubo estarán limpios de grasa y suciedad (\*). ◀

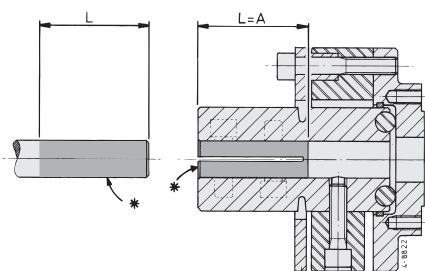

Asegurar que las partes de caucho no sean afectadas por disolventes. ◀

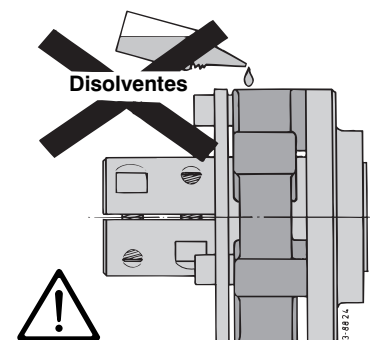

## Especificaciones técnicas

Bullflex		1	2	4	8	12	16	32	
Par máximo según	DIN6270B	75	150	300	600	900	1200	2200	N.m
		7,6	15	30	61	92	122	220	kgf.m
	DIN6270A	45	90	200	410	540	935	1780	N.m
		4,6	9	20	42	55	95	178	kgf.m
Potencia máximo según	DIN6270B	0,8	1,6	3,1	6,3	9,4	12,6	23,0	kW/100 min <sup>-1</sup>
		1.1	2.1	4.3	8.5	12.8	17.1	31.3	hp/100 RPM
	DIN6270A	0,5	0,9	2,1	4,3	7,1	9,8	18,6	kW/100 min <sup>-1</sup>
		0.6	1.3	2.8	5.8	9.6	13.3	25.3	hp/100 RPM
Momento de inercia	J	23·10 <sup>-4</sup>	57·10 <sup>-4</sup>	158·10 <sup>-4</sup>	300·10 <sup>-4</sup>	595·10 <sup>-4</sup>	710·10 <sup>-4</sup>	2058·10 <sup>-4</sup>	kg.m <sup>2</sup>
	GD <sup>2</sup>	0,009	0,023	0,063	0,12	0,23	0,28	0,82	kgf.m <sup>2</sup>
Rigidez dyn. de torsión		460	820	1850	6850	10900	13700	24400	N.m/rad
		12,46	6,99	3,10	0,84	0,52	0,42	0,23	°/100 N.m
Rigidez axial de compresión		1,3	3,2	3,9	5,3	6,5	6,7	7,9	kN/mm
		133	331	395	542	665	678	804	kgf/mm
Rigidez axial de tracción		0,05	0,05	0,07	0,37	0,43	0,57	0,43	kN/mm
		5	5	7	38	44	58	44	kgf/mm
Desplazamiento angular máx.		2°	2°	2°	2°	2°	2°	2°	
Número de revoluciones máx. con	2°	3500	3250	3000	2500	2000	2000	1800	min <sup>-1</sup> , RPM
	0°	7000	6500	6000	5000	4000	4000	3600	
Fuerza de propulsión máx.		2000	5000	5000	8000	9000	10000	20000	N
		204	510	510	816	917	1020	2040	kgf
Peso, aprox.		3	4,5	6,9	12	17	19	38	kg

## Montaggio

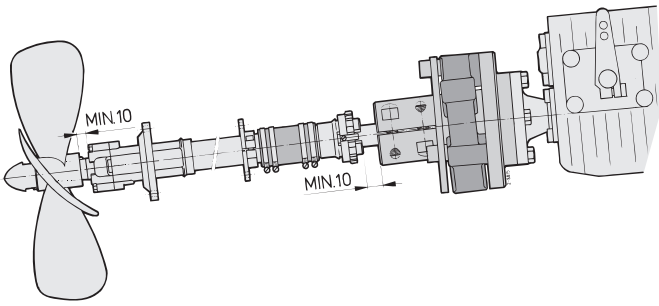

Tenendo conto del movimento assiale dell'albero dell'elica, è necessario lasciare uno spazio libero minimo fra la sospensione esterna e il mozzo dell'elica. ◀

## Forza di propulsione

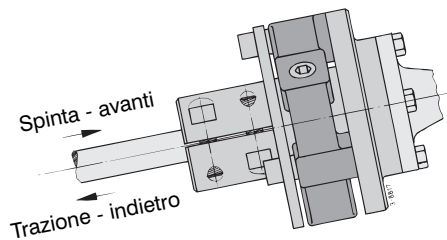

N.B. Durante la marcia in avanti la parte in gomma deve essere premuta! ◀

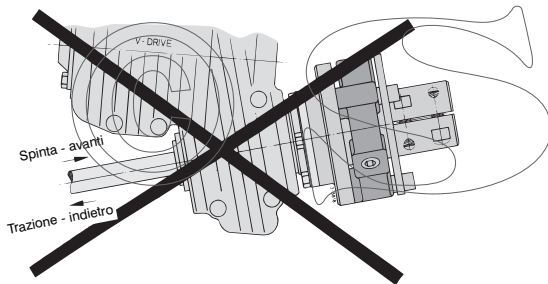

L'uso del Bullflex in combinazione con una trasmissione tipo V-drive non è permesso! ◀

## Diametro diverso (più grande) dell'albero dell'elica

Ridurre il diametro dell'albero dell'elica sulla lunghezza del fermo (dimensione 'A') fino a raggiungere la dimensione 'd' dell'accoppiamento, vedi Dimensioni Principali. Raggio 'r' minimo 2 mm. ◀

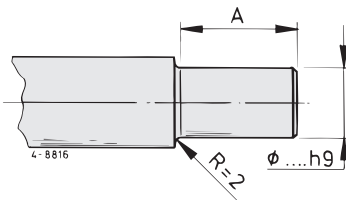

## Errore di allineamento

L'errore di allineamento massimo consentito dell'albero dell'elica è di 2°. ◀

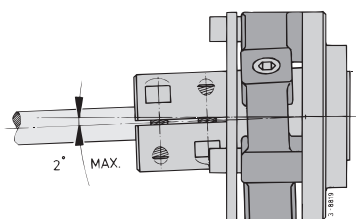

## Anello di centraggio

Un motore marino su sospensioni flessibili si muove sempre, per definizione.

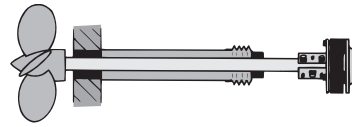

Se l'albero ha soltanto una sospensione fissa, il giunto di accoppiamento Bullflex -con l'anello di centraggio- funge da giunto sferico flessibile, vedi A. ◀

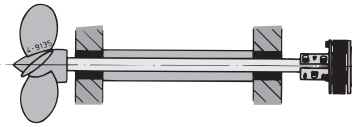

Nel caso in cui l'albero sia montato in modo rigido -ed abbia quindi 2 (o più) sospensioni fisse- l'albero non deve poter risentire dei movimenti del motore. In questo caso togliere l'anello di centraggio, vedi B. ◀

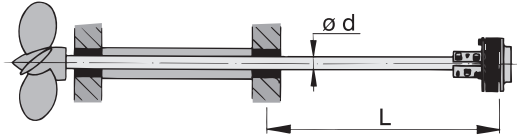

Quando la lunghezza 'L' dell'albero dell'elica tra il cuscinetto interno fisso e la flangia del cambio direzionale è maggiore di 20 volte il diametro dell'albero dell'elica 'd', **non** rimuovere l'anello di centraggio. ◀

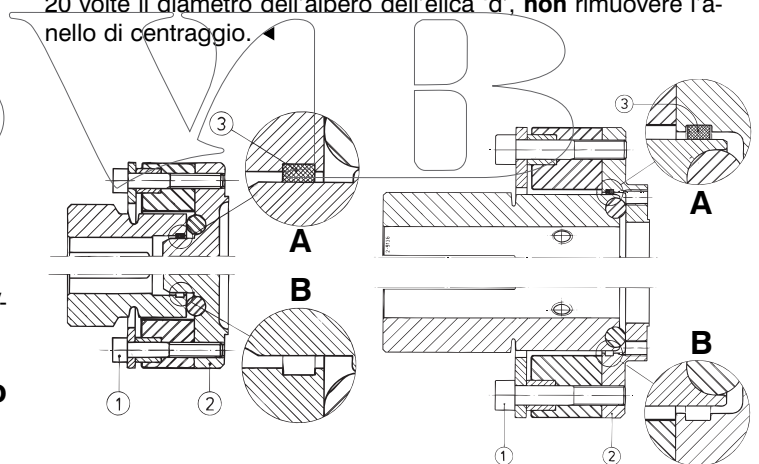

Bullflex 1

Bullflex 2, 4, 8, 12, 16, 32

## Come togliere l'anello di centraggio:

Svitare i bulloni ①. Svitare la flangia ② dal mozzo e togliere l'anello di centraggio ③. Rimettere al suo posto la flangia e rimontare i bulloni (con un prodotto bloccante, LOCTITE 222 Screwlock) e avvitarli con il momento 'T1' indicato, vedi tabella. Assicurarsi che i fori nella flangia e nell'elemento in gomma siano in linea durante il montaggio dei bulloni. A questo scopo deformare l'elemento in gomma per mezzo di un sergente. ◀

Bullflex		T1
1	M8	25 Nm
2	M10	50 Nm
4	M12	90 Nm
8	M14	140 Nm
12	M16	220 Nm
16	M16	220 Nm
32	M20	430 Nm

## Montaggio, generalità

Per ottenere un giunto di accoppiamento che funzioni in modo affidabile, tutti i bulloni e tutti i dadi devono essere avvitati con il momento indicato. A questo scopo utilizzare una chiave dinamometrica; avvitando in modo approssimativo non si ottengono risultati soddisfacenti. ◀

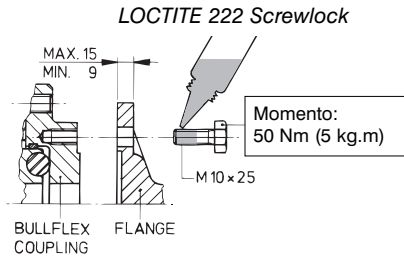
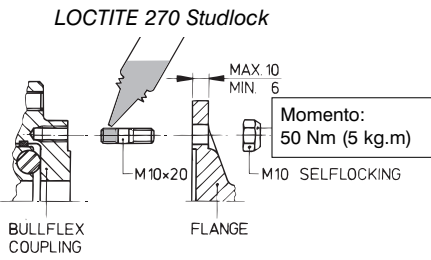

Bullflex		T2
1	M10x30	60 Nm
2	M10x35	60 Nm
4	M12x40	100 Nm
8	M14x45	200 Nm
12	M16x50	320 Nm
16	M16x55	230 Nm
32	M20x70	450 Nm

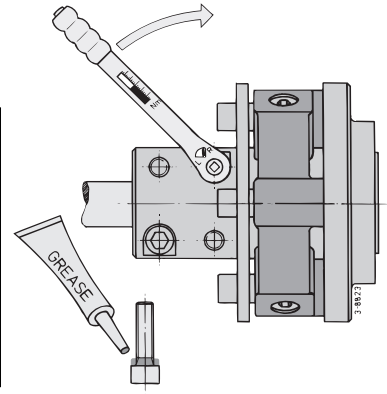

Stringere i bulloni con il momento 'T2' indicato, vedi tabella. ◀

L'albero dell'elica deve essere inserito nel mozzo per una lunghezza sufficiente (L) e sia l'albero che il mozzo devono essere privi di grasso e di sporco (\*). ◀

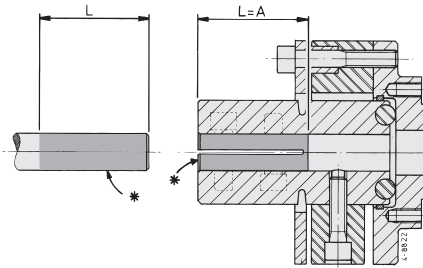

Assicurarsi che le parti in gomma non vengano corrose dai solventi. ◀

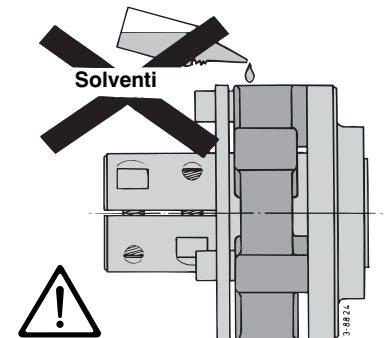

## Dati tecnici

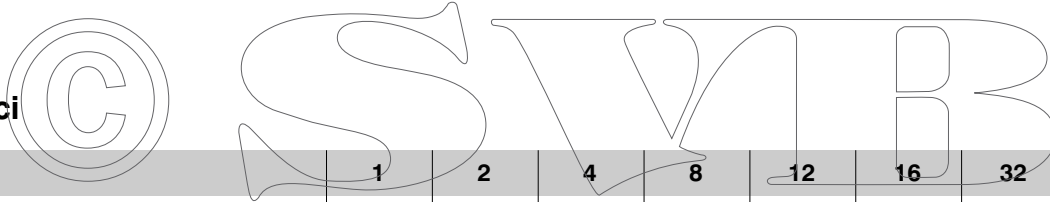

Bullflex		1	2	4	8	12	16	32	
Momento max. secondo	DIN6270B	75	150	300	600	900	1200	2200	N.m
	DIN6270A	7,6	15	30	61	92	122	220	kgf.m
Potenza max. secondo	DIN6270B	45	90	200	410	540	935	1780	N.m
	DIN6270A	4,6	9	20	42	55	95	178	kgf.m
Momento d'inerzia	DIN6270B	0,8	1,6	3,1	6,3	9,4	12,6	23,0	kW/100 min <sup>-1</sup>
	DIN6270A	1,1	2,1	4,3	8,5	12,8	17,1	31,3	hp/100 RPM
Rigidità torsionale din.	DIN6270B	0,5	0,9	2,1	4,3	7,1	9,8	18,6	kW/100 min <sup>-1</sup>
	DIN6270A	0,6	1,3	2,8	5,8	9,6	13,3	25,3	hp/100 RPM
Momento d'inerzia	J	23·10 <sup>-4</sup>	57·10 <sup>-4</sup>	158·10 <sup>-4</sup>	300·10 <sup>-4</sup>	595·10 <sup>-4</sup>	710·10 <sup>-4</sup>	2058·10 <sup>-4</sup>	kg.m <sup>2</sup>
	GD <sup>2</sup>	0,009	0,023	0,063	0,12	0,23	0,28	0,82	kgf.m <sup>2</sup>
Rigidità assiale alla compressione		460	820	1850	6850	10900	13700	24400	N.m/rad
		12,46	6,99	3,10	0,84	0,52	0,42	0,23	°/100 N.m
Rigidità assiale alla trazione		1,3	3,2	3,9	5,3	6,5	6,7	7,9	kN/mm
		133	331	395	542	665	678	804	kgf/mm
Spostamento angolare massimo		0,05	0,05	0,07	0,37	0,43	0,57	0,43	kN/mm
		5	5	7	38	44	58	44	kgf/mm
Numero max. di giri a	2°		2°	2°	2°	2°	2°	2°	2°
	0°	3500	3250	3000	2500	2000	2000	1800	min <sup>-1</sup> , RPM
Propulsione max.		7000	6500	6000	5000	4000	4000	3600	
		2000	5000	5000	8000	9000	10000	20000	N
Peso, circa		204	510	510	816	917	1020	2040	kgf
		3	4,5	6,9	12	17	19	38	kg

Schaal 1:5  
 Scale 1:5  
 Maßstab 1:5  
 Echelle 1:5  
 Escala 1:5  
 Scala 1:5

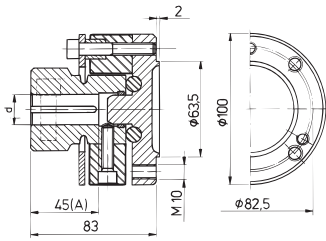

**Bullflex 1** d: 20 mm  
 25 mm  
 1 inch

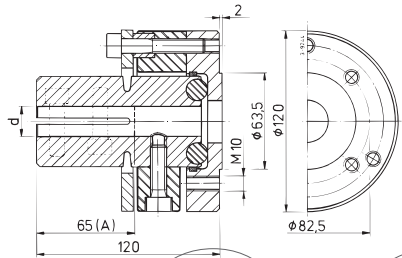

**Bullflex 2** d: 20 mm  
 25 mm  
 1 inch

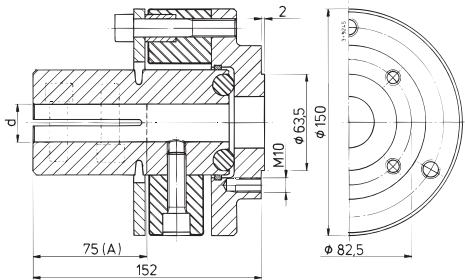

**Bullflex 4** d: 20 mm  
 25 mm  
 1 inch

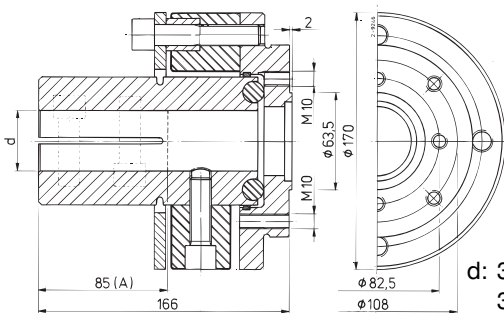

**Bullflex 8** d: 30 mm  
 35 mm  
 40 mm  
 1 1/4 inch  
 1 1/2 inch

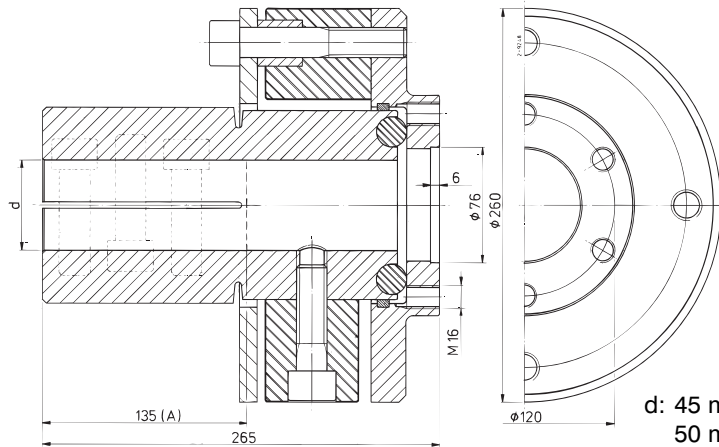

**Bullflex 32**

d: 45 mm  
 50 mm  
 60 mm  
 70 mm  
 1 3/4 inch  
 2 inch

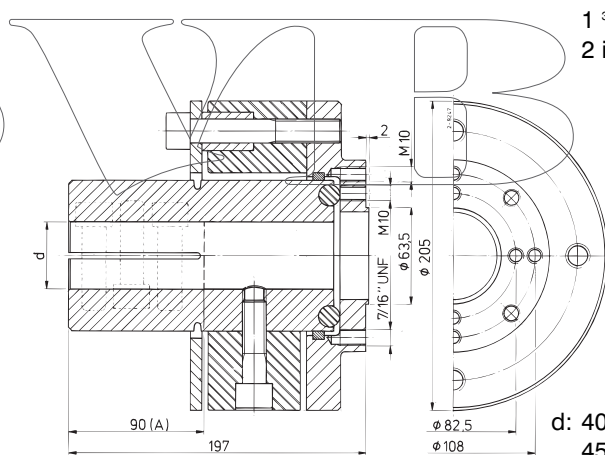

**Bullflex 16**

d: 40 mm  
 45 mm  
 50 mm  
 1 1/2 inch  
 1 3/4 inch  
 2 inch

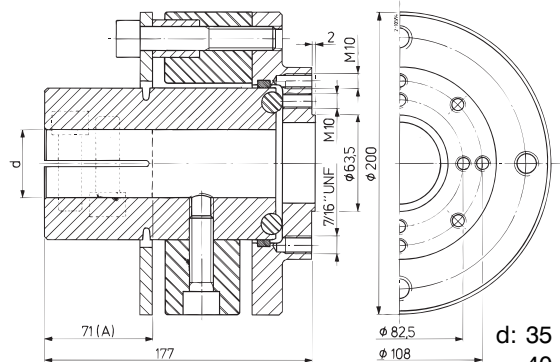

**Bullflex 12**

d: 35 mm  
 40 mm  
 45 mm  
 1 1/2 inch  
 1 3/4 inch

**Na demontage:**

**After disassembly:**

**Nach der Demontage:**

**Après le démontage:**

**Después del desmontaje:**

**Dopo lo smontaggio:**

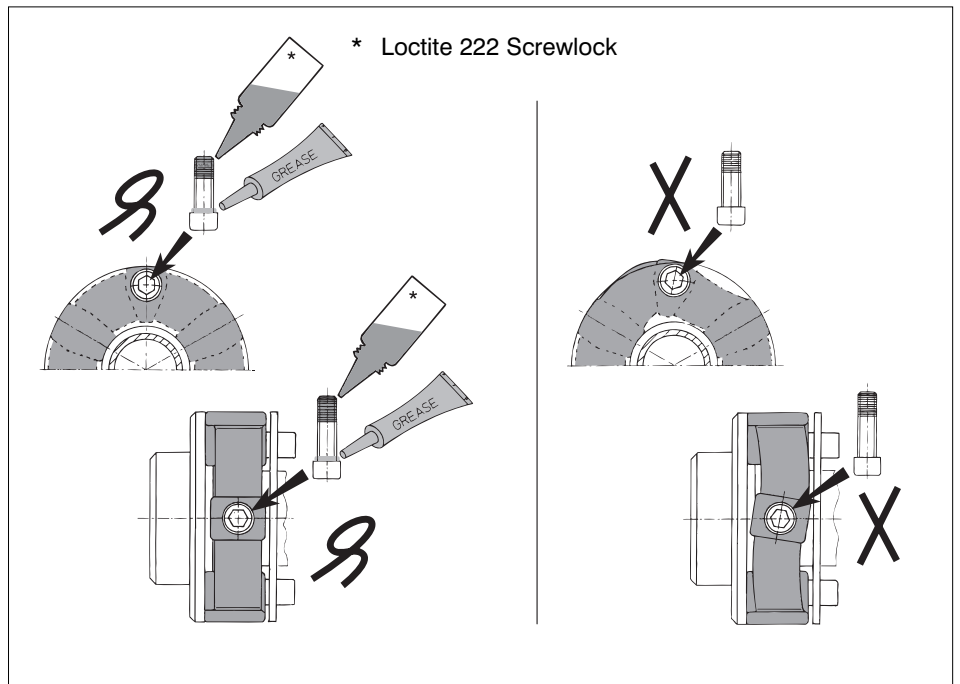

**Verloopflenzen**

**Adapter flanges**

**Zwischenflanschen**

**Brides d'adaptation**

**Bridas de adaptación**

**Flange di adattamento**

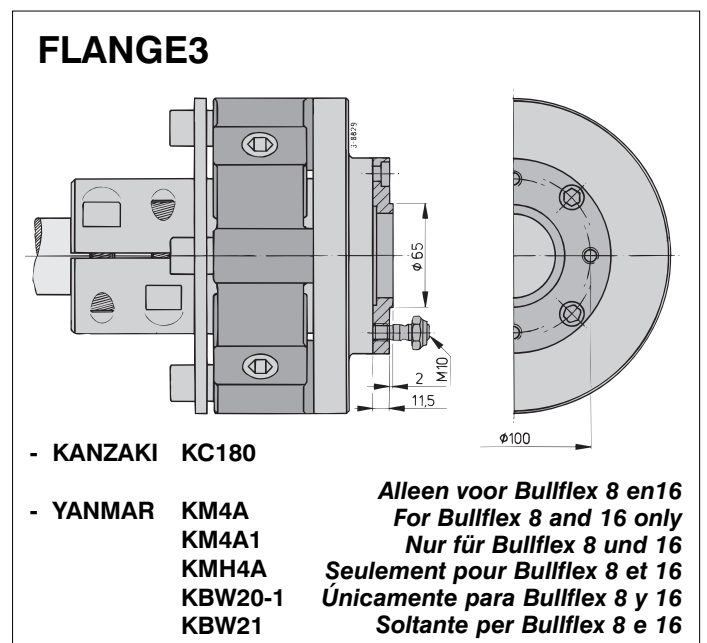
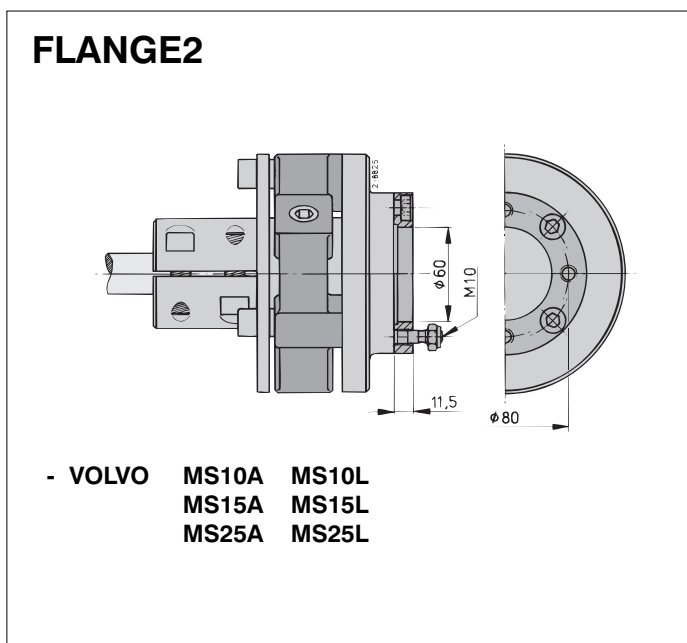
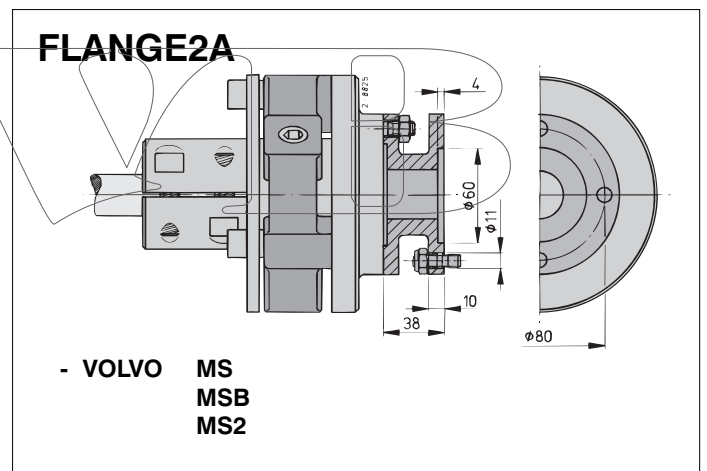
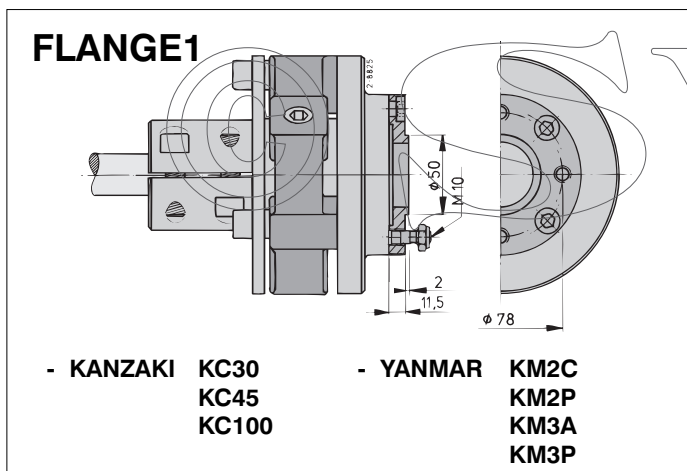

© SVIB

***vetus den ouden n.v.***

FOKKERSTRAAT 571 - 3125 BD SCHIEDAM - HOLLAND - TEL.: +31 10 4377700 - TELEX: 23470  
TELEFAX: +31 10 4372673 - 4621286 - E-MAIL: sales@vetus.nl - INTERNET: <http://www.vetus.nl>

Printed in the Netherlands

3.0205 I.BULLFL 09-94 Rev. 02-95, 09-95, 05-96, 07-96, 04-00, 01-01, 02-03, 08-04